

**MODELLING AND SIMULATION OF WAVE ENERGY POTENTIAL ACROSS THE
NIGERIAN COASTLINE**



EFETOBOR HENRY OGHENETEJIRI.

MAT NO: ENG2002365

ERONMOSELE OKODUWA VICTOR.

MAT NO: ENG2002375

OSAZUWA DESTINY OSAGIE.

MAT NO: ENG2002384

**DEPARTMENT OF MARINE ENGINEERING,
FACULTY OF ENGINEERING,
UNIVERSITY OF BENIN, BENIN CITY,
EDO STATE, NIGERIA.**

**SUPERVISOR:
DR. I.B. OWUNNA**

NOVEMBER 2025

CERTIFICATION

This is to certify that the work in this project work **MODELLING AND SIMULATION OF WAVE ENERGY POTENTIAL ACROSS THE NIGERIA COASTLINE** was carried out by;

EFETOBOR HENRY OGHENETEJIRI.	MAT NO: ENG2002366
ERONMOSELE OKODUWA VICTOR.	MAT NO: ENG2002375
OSAZUWA DESTINY OSAGIE.	MAT NO: ENG2002384

Of the Department of Marine Engineering, Faculty of Engineering, University of Benin, Benin City, Edo state, Nigeria.

_____	_____
DR. I.B. OWUNNA.	DATE
PROJECT SUPERVISOR	

_____	_____
ENGR. WISDOM JAJA.	DATE
PROJECT COORDINATOR	

_____	_____
PROF. OSAROBO O. IGHODARO	DATE
HEAD OF DEPARTMENT	
MECHANICAL ENGINEERING DEPARTMENT	

DEDICATION

This project work is solely dedicated to God Almighty for strength, love and guidance for making this report a reality

ACKNOWLEDGEMENT

We wish to express our sincere gratitude to Dr. I. B. Owunna, our project supervisor, for his invaluable guidance, encouragement, and support throughout the course of this project. His expertise and commitment were instrumental to its success.

Our heartfelt appreciation also goes to Mr. and Mrs. Efebor, Mr. and Mrs. Okoduwa, and Mr. and Mrs. Osazuwa for their constant prayers, encouragement, and unwavering support.

We extend our thanks to all the lecturers and staff of the Department of Mechanical Engineering, University of Benin, for imparting the knowledge and skills that made this work possible.

Finally, a special thanks to our coursemates for their cooperation, motivation, and friendship throughout this journey.

TABLE OF CONTENT

Title page	i
Certification	ii
Dedication	iii
Acknowledgement	iv
Table of Contents	v
List of figures	viii
Nomenclature	ix
Abstract	xi
CHAPTER 1: INTRODUCTION	
1.1 Background of the study	1
1.2 Stattement of the problem	2
1.3 Aim of the study	3
1.4 Objective of the study	3
1.5 Significance of the study	3
1.6 Scope of the study	5
1.7 Justification of the study	6
CHAPTER 2: LITERATURE REVIEW	
2.1 Fundamental Wave Energy Principles	8
2.1.1. Classification of Wave Energy Harvesters	8
2.1.2. Point Absorber Wave Energy Conversion Systems	10
2.1.3. Single Body Point Absorber Mathematical Modeling	11
2.1.3.1. Hydrodynamic Principles	13
2.1.3.2. Wave Excitation Force Analysis	13

2.1.3.3. Wave Radiation Force Mechanics	13
2.1.4. Dual Body Point Absorber Configurations	15
2.1.5. Power Take Off System Technologies	17
2.1.6. Wave Energy Harvesting Technical Challenges	19
2.2. Studies on Nigerian Wave Energy Potential	20
2.2.1. Research by Enikanselu et al. (2025)	20
2.2.2. Research by Dickson Festus and Jamu Benson Yerima (2025)	21
2.2.3. Research by Abdulkadir and Ibe (2024)	22
2.2.4. Research by Nwaokocha and Layeni (2013)	22
CHAPTER 3: MATERIALS AND METHOD	
3.1. Materials	24
3.2. Methods	25
3.2.1. Data Acquisition and Processing	25
3.2.2. Dynamic Model Development	27
3.2.3. Simulation and Energy Calculation	29
3.2.4. Results and Analysis	30
3.3. Detailed Breakdown of Simulation Setup	30
CHAPTER 4: RESULTS AND DISCUSSIONS	
4.1. Simulation Results	32
4.2. Discussions	34
4.2.1. Analysis of Wave Power Density Graph	34
4.2.2. Analysis of Instantaneous Power Output Graph	35
4.2.3. Analysis of Cumulative Energy Graph	37

CHAPTER 5: CONCLUSION AND RECOMMENDATIONS

5.1. Overall View of the Project	38
5.2. Limitations	39
5.2.1. Project Limitations	39
5.2.2. Implementation Limitations	40
5.3. Recommendations	40
5.3.1. Recommendations for Further Research	41
5.3.2. Recommendations for Policy and Implementation	41
5.4. Final Conclusion	42
References	44

LIST OF FIGURES

	Page
Figure 2.1: Captured power of a point absorber WEC vs. wave period calculation using different	9
Figure 2.2: Schematic of a point absorber with a linear generator PTO	10
Figure 2.3: Direct drive cylindrical one body point absorber WEC	11
Figure 2.4: Deployment of a WEC developed by Uppsala university in the sea	15
Figure 2.5: Wavebob (left) and Power buoy (right) dual-body point absorber configurations	16
Figure 2.6: Power capture width ratio for different buoy dimensions with and without a submerged body, VS. the energy period T_e	17
Figure 2.7: Crank slider mechanism schematic	19
Figure 3.1: Data extraction from Copernicus Marine Service website	25
Figure 3.2: Average mean wave period processed and plotted using Matlab	26
Figure 3.3 : Averaged significant wave height processed and plotted using Matlab	27
Figure 3.4: Simulink Model of overall wave energy harvester	28
Figure 3.5: Simulink model of wave power density	28
Figure 3.6: Simulink model of capture width	29
Figure 3.7: Simulink model of wave frequency	29
Figure 4.1: Simulation result for total energy output	32
Figure 4.2: Simulation result for instantaneous power over a year	33
Figure 4.3: Simulation result for wave power density over a year	34
Figure 4.4.: Graph showing instantaneous power following the same trend as energy Density	36

NOMENCLATURE

WEC - Wave Energy Converter

OWC - Oscillating Water Column

PTO - Power Take-Off

CFD - Computational Fluid Dynamics

ECMWF -European Centre for Medium-Range Weather Forecasts

CMEMS - Copernicus Marine Environment Monitoring Service

ERA5 - Fifth Generation ECMWF Reanalysis Dataset

Hs - Significant Wave Height

Te - Mean Wave Period (Energy Period)

Tm - Peak Wave Period

J - Wave Power per Unit Length (Wave Power Density)

Cw - Capture Width

ω - Angular Frequency (rad/s)

$m_{a\infty}$ - Hydrodynamic Added Mass at Infinite Frequency

RIF - Radiation Impulse Response Function

c_r - Radiation Damping Coefficient

k_{hs} - Hydrostatic Stiffness

c_{vd} - Linearized Viscous Damping Coefficient

k_p - PTO Stiffness Coefficient

cp - PTO Damping Coefficient

Fwe - Wave Excitation Force

LCOE - Levelized Cost of Energy

ROI - Return on Investment

MWh - Megawatt-hour

kW - Kilowatt

DC - Direct Current

AC - Alternating Current

TFPM - Transverse Flux Permanent Magnet (Generator)

SSW - South Southwest (Wave Direction)

ABSTRACT

This study models and simulates the wave energy potential along Nigeria's coastline to evaluate its feasibility as a sustainable power source. With the nation facing persistent energy deficits and heavy dependence on fossil fuels, wave energy offers a clean and renewable alternative. Using real world oceanographic data from the Copernicus Marine Service (ERA5 dataset), key wave parameters significant wave height (H_s) and mean wave period (T_e) were extracted and processed in MATLAB. A dynamic heaving point absorber Wave Energy Converter (WEC) model was then developed in Simulink to simulate power generation over a one year period (September 2024–September 2025). The simulation results show that a single 5-meter wide point absorber can generate approximately 13.88 MWh annually, with peak outputs during the summer months when wave activity is highest. The findings confirm that Nigeria's wave climate, though moderate, is consistent and technically viable for decentralized, off grid energy applications, particularly for coastal communities and small industries. This research provides a quantitative foundation for future investment, policy development, and pilot projects aimed at integrating marine renewable energy into Nigeria's sustainable energy mix.

CHAPTER 1

INTRODUCTION

1.1. Background of the Study

The world's increasing reliance on fossil fuels has led to an urgent need for sustainable and clean energy alternatives to address climate change and ensure energy security. Among various renewable sources, wave energy has emerged as a promising option due to its high energy density and predictability. As a by product of solar energy, wave power is generated by the uneven heating of the atmosphere, which creates winds that, in turn, form waves propagating across the ocean surface (Nwaokocha and Layeni, 2013). This energy concentration is significant; per unit volume of energy, solar radiation ($0.1\text{--}0.3 \text{ kWm}^{-2}$) is converted into wind energy (0.5 kWm^{-2}), which then generates ocean waves with a much higher energy content ($2\text{--}3 \text{ kWm}^{-2}$) (Falnes, 2002). This inherent density makes wave energy a powerful and consistent renewable resource (Dickson and Yerima, 2025).

Globally, the potential of wave energy is immense. It is estimated that harnessing less than 0.1% of the available energy within the oceans could satisfy the world's current energy demand more than five times over (Nwaokocha and Layeni, 2013). However, the practical application of wave energy is not without its technical challenges. One major hurdle is seasonal variation in sea states, which complicates the design of a Wave Energy Converter (WEC) capable of operating efficiently year-round (Al Shami et al., 2019). Additionally, highly energetic locations often have large wave periods, which necessitates the use of very large, massive devices to match the device's natural frequency with the wave frequency for optimal energy capture (Al Shami et al., 2019).

In the Nigerian context, the country faces significant energy challenges, including an unreliable grid and a heavy reliance on fossil fuels. Despite these challenges, wave energy presents a promising, clean, and consistent resource along its vast coastline. Recent studies have begun to quantify this potential, revealing that while the Nigerian wave climate is generally considered low to moderate, it is a viable resource. For example, studies on the Brass Coast in Rivers State and locations in Delta State have shown annual mean wave power densities ranging from 7.63

kW/m to over 31 kW/m (Dickson and Yerima, 2025; Abdulkadir and Ibe, 2024). While some coastal areas may have lower energy potential, better suited for non grid applications (Enikanselu et al., 2025), the overall resource is consistent and available.

This study aims to contribute to the existing research by providing a comprehensive and technical analysis of the wave energy potential across not just specific locations but the entire coastline of Nigeria. By using advanced modelling techniques, this research seeks to determine the practical viability of wave energy as a clean, consistent, and sustainable power source to supplement Nigeria's current energy mix.

1.2. Statement of the Problem

Nigeria, like many developing nations, faces a persistent and critical energy deficit. Despite being a major oil and gas producer, the country's national electricity grid is highly unreliable, characterized by frequent blackouts and an inability to meet the demands of its growing population and industrial sector. This forces many businesses and households to rely on expensive, noisy, and polluting diesel and gasoline generators, which not only contribute to high operational costs but also exacerbate environmental issues through carbon emissions and localized air pollution.

While Nigeria possesses a vast coastline with significant ocean wave activity, the potential of this renewable energy source remains largely untapped. The lack of detailed, site-specific data on wave energy potential and the absence of a comprehensive technical analysis on the performance of modern wave energy converters (WECs) in the Nigerian context are major barriers to investment and development. The available studies are often fragmented, providing general assessments rather than the detailed, location-specific, and time series based simulations needed to justify a business case for a wave energy project.

The central problem this study seeks to address is the absence of a quantifiable, data driven analysis on the energy generation capacity of a wave energy harvester deployed along the Nigerian coastline. This knowledge gap prevents stakeholders, including government bodies, investors, and coastal communities, from making informed decisions about the viability of wave energy as a reliable, clean, and sustainable power alternative. Therefore, a detailed technical

report is needed to model and simulate the energy and power output of a WEC, providing concrete data that can serve as a foundation for future renewable energy initiatives in Nigeria.

1.3. Aim of the Study

The primary aim of this study is to model and simulate the wave energy potential of the Nigerian coastline to determine the total energy that can be generated by a single 5 meter wide heaving point absorber wave energy harvester over a one year period (September 2024 to September 2025). The study seeks to provide a quantitative analysis that validates the technical viability of wave energy as a reliable, decentralized power source in Nigeria.

1.4. Objectives of the Study

The following objectives will be pursued to achieve the aim of this study:

1. **Understand Wave Energy Conversion:** Gain a comprehensive technical understanding of how Wave Energy Converters (WECs) operate, with a specific focus on the principles, design, and performance characteristics of heaving point absorber devices.
2. **Acquire and Process Wave Data:** Systematically extract high resolution, time series data for significant wave height (H_s) and mean wave period (T_e) for the Nigerian coastline from the Copernicus Marine Service for the specified period.
3. **Develop a Dynamic Simulation Model:** Construct a dynamic model of a 5 meter wave energy harvester in MATLAB and Simulink, incorporating real world data and the governing wave power equations to simulate power output over time.
4. **Simulate and Quantify Energy Output:** Run the Simulink model using the processed wave data to simulate the power generated and then calculate the total annual energy yield in megawatt-hours (MWh).
5. **Evaluate and Report Findings:** Analyze the simulation results to provide a detailed technical report on the energy potential, highlighting the feasibility and potential applications of wave energy in Nigeria, particularly for powering coastal communities and industries.

1.5. Significance of the Study

This study holds significant importance for several key stakeholders in Nigeria's energy sector and coastal development. Its contributions are twofold: academic and practical.

- **Academic Significance**

This research addresses a critical gap in the existing literature on Nigeria's renewable energy potential. While previous studies have provided general overviews of wave energy, this work offers a detailed, time series based simulation of a specific wave energy converter (WEC). By employing a dynamic MATLAB/Simulink model with real world wave data, the study moves beyond theoretical assessments to provide a tangible and quantifiable energy output. This methodology can serve as a template for future, more granular analyses of specific sites, contributing a robust and repeatable framework for marine renewable energy research in the region.

- **Practical Significance**

The practical implications of this study are far reaching for Nigeria's development and energy security.

- **Informed Investment:** The simulation's concrete MWh output provides a crucial business case for potential investors, project developers, and government agencies. It translates abstract energy potential into a tangible metric, enabling a more accurate calculation of return on investment, project feasibility, and financial planning. This data can unlock much-needed funding for wave energy pilot projects.
- **Decentralized Power Generation:** The study's focus on a single harvester demonstrates the potential for decentralized power solutions. This is particularly significant for Nigeria's numerous coastal communities and industries (e.g., fishing, tourism) that are either unserved or underserved by the national grid. Wave energy can provide a reliable, clean, and locally sourced alternative to expensive and polluting diesel generators, fostering economic growth and improving quality of life.
- **Environmental Sustainability:** By quantifying the potential for clean energy generation, this research supports Nigeria's climate goals and commitments to reducing carbon

emissions. Promoting wave energy can lessen the country's reliance on fossil fuels, leading to cleaner air and water, and a more sustainable blue economy.

- **Basis for Policy Development:** The findings provide essential data for policymakers to formulate effective and targeted renewable energy policies. It can inform decisions on a national energy strategy, regulatory frameworks for marine energy, and incentives for private sector investment in this nascent but promising sector.

1.6. Scope of the Study

This study is focused on a specific, technical analysis of wave energy as a renewable resource. The scope is defined by the following parameters:

- **Geographical Scope:** The study is limited to the coastline of Nigeria, covering the region from approximately Latitude 4.0°N to 6.5°N and Longitude 2.5°E to 8.5°E. The analysis is based on aggregated data for this entire coastal area, rather than on a single, site specific location.
- **Temporal Scope:** The simulation and analysis are strictly confined to a one-year period, from September 2024 to September 2025. This timeframe is chosen to capture a full cycle of seasonal wave variations and provide a robust annual energy yield estimate.
- **Data and Tools:** The research relies exclusively on publicly available data from the Copernicus Marine Service for significant wave height and mean wave period. All modelling and simulation work are conducted using the MATLAB and Simulink software environments.
- **Device Type:** The study focuses on a single, idealized wave energy harvester of the heaving point absorber type, with a specified physical width of 5 meters. The analysis does not include other types of wave energy converters (e.g., oscillating water columns, overtopping devices).
- **Technical Limitations:** The model assumes idealized conditions, excluding complex real world factors such as device mooring dynamics, biofouling, and extreme weather events. The analysis is limited to the technical feasibility of energy generation and does not delve into the economic, environmental, or social aspects of commercial deployment, such as the Levelized Cost of Energy (LCOE), grid integration, or regulatory frameworks.

1.7. Justification for the Study

This study is of significant importance for the sustainable development of Nigeria, as it directly addresses critical challenges facing the country's energy sector. The justification for this research is rooted in three key areas: economic necessity, environmental imperative, and the need for a data driven approach.

▪ Economic Justification

Nigeria's economy, heavily reliant on fossil fuels, is vulnerable to global market fluctuations and the high operational costs associated with conventional energy sources. The current dependence on diesel and gasoline generators for power is not only expensive for businesses and individuals but also a major obstacle to industrial growth and economic diversification. This study provides a concrete, quantitative analysis of a potential new energy source. By simulating the annual energy output of a wave energy harvester, it provides the foundational data necessary for investors and policymakers to conduct accurate financial feasibility studies. The findings can help justify a business case for the private sector to invest in wave energy projects, thereby fostering the development of a new, sustainable industry and creating jobs.

▪ Environmental Justification

The widespread use of fossil fuels for power generation contributes significantly to air and noise pollution, as well as to Nigeria's overall carbon footprint. Wave energy, as a clean and renewable resource, offers a viable alternative that can help mitigate these environmental harms. By demonstrating the energy potential of wave power, this study advocates for a transition towards a cleaner energy mix. The research serves as a technical proof of concept that can inform and support Nigeria's national and international commitments to climate action and environmental sustainability.

▪ Data Driven Justification

A primary barrier to the development of marine renewable energy in Nigeria is the lack of detailed, reliable, and location specific data. Previous studies have often provided general assessments, which are insufficient for attracting serious investment or guiding policy. This study fills this critical knowledge gap by employing a rigorous, technical methodology using real

world data and a dynamic simulation model. The results provide a robust, evidence based foundation for future research, pilot projects, and policy decisions. It moves the conversation about wave energy from theoretical possibility to practical, quantifiable reality, offering a clear and compelling justification for its inclusion in Nigeria's energy future.

CHAPTER 2

LITERATURE REVIEW

This literature review explores the foundational principles of wave energy, the classification of its harvesting technologies, and the technical complexities associated with their design and deployment, providing a context for this study on the Nigerian coastline.

2.1. Fundamental Wave Energy Principles

Wave energy originates from solar radiation, as the sun's uneven heating of the atmosphere generates winds, which in turn create ocean waves (Falnes, 2002). This process highlights a critical advantage of wave energy: its remarkable energy density. According to Falnes (2002), solar radiation's energy density of 0.1–0.3 kW/m² is concentrated into wind energy at 0.5 kW/m², and finally into ocean waves, which can contain 2–3 kW/m². This makes wave energy a significantly more potent source than other renewables.

The power of a wave is determined by its physical characteristics. The power contained within a unit length of a wavefront (J) is a function of the significant wave height (H_s) and the energy period (T_e). The formula for power density in deep water is given by:

$$J = \left(\frac{1}{64\pi}\right) \rho g^2 H_s^2 T_e$$

This equation shows that wave power is proportional to the square of the wave height, making it highly sensitive to wave conditions.

2.1.1. Classification of Wave Energy Harvesters

The field of wave energy has seen extensive innovation, with thousands of patents and designs documented (Drew, Plummer, and Sahinkaya, 2016). These devices, known as Wave Energy Converters (WECs), are broadly classified into three main types based on their operating principles:

- **Oscillating Water Columns (OWC):** These devices use a partially submerged structure to trap an air pocket, which is compressed and decompressed by the incoming waves, driving an air turbine.
- **Overtopping Devices:** These systems capture waves in a reservoir at a higher elevation than the average sea level. The stored water is then released, flowing back to the sea through a low head turbine to generate electricity.
- **Oscillating Body Systems:** These devices utilize the motion of a floating or submerged body to extract energy.

Most WECs, including oscillating body systems, rely on the principle of **resonance** to maximize energy capture. When the natural resonant frequency of the device aligns with the frequency of the incoming waves, a peak in power absorption occurs (Li and Yu, 2012). This principle is central to the design and optimization of WECs.

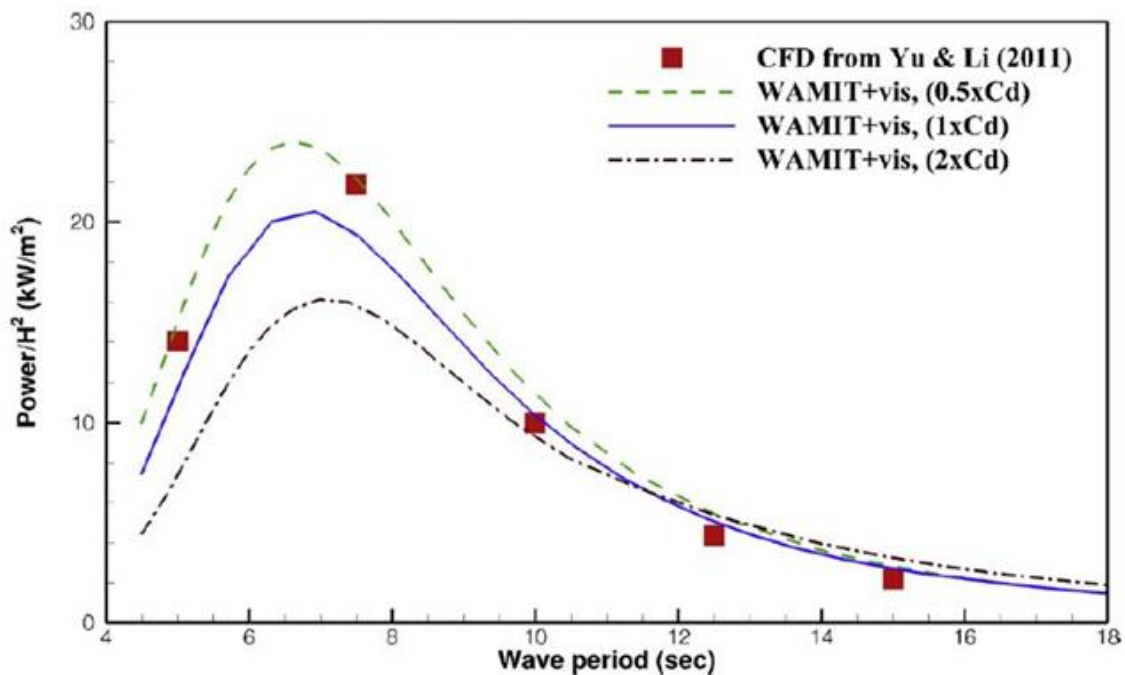

Figure 2.1: Captured power of a point absorber WEC vs. wave period calculation using different(Li and Yu, 2012)

2.1.2. Point Absorber Wave Energy Conversion Systems

Point absorber devices represent a category of floating oscillatory mechanisms that harness wave energy through heaving buoy motion. These systems extract energy via Power Take Off (PTO) components that capitalize on relative displacement between the buoy and either a fixed reference point (single body configuration) or a submersed oscillating element (dual body configuration).

Historical development traces back to Leavitt's 1885 patent, which proposed harnessing wave forces through a heaving buoy mechanism coupled to rack-and-gear assemblies for water pumping and air compression applications (Leavitt, 1885). Theoretical advancement of heaving buoy systems evolved alongside maritime hydrodynamic research throughout the 1900s, building upon ship and marine structure studies (Evans et al., 1986; Falnes, 1995; Cummins, 1962; Falnes, 1999).

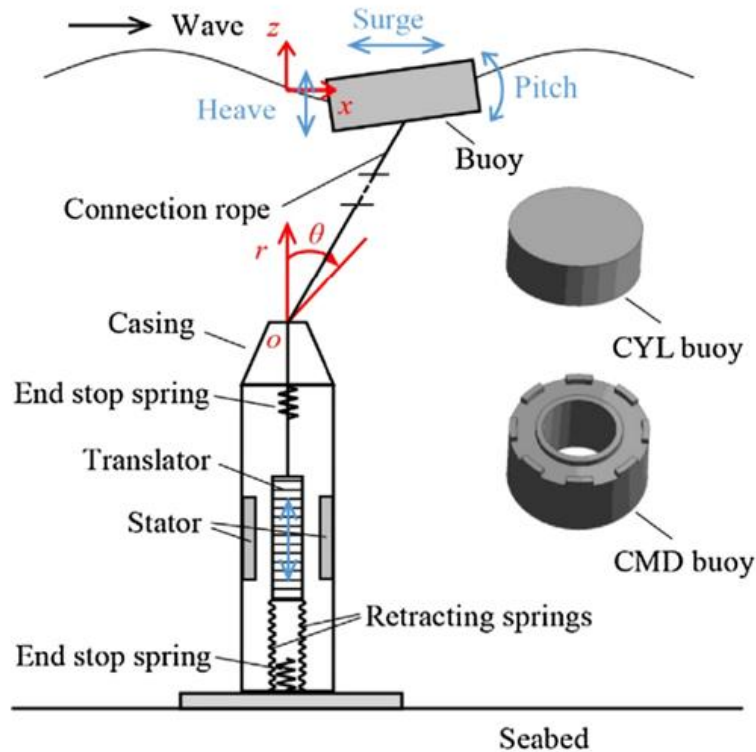

Figure 2.2: Schematic of a point absorber with a linear generator PTO (Chen et al., 2017)

2.1.3. Single Body Point Absorber Mathematical Modeling

This is the simplest type of all wave energy harvesters as it basically consists of a single floating structure typically featuring cylindrical, spherical, or hollow cylindrical geometry that responds to wave induced forces through oscillatory motion relative to a stationary reference point, commonly the seafloor. The system incorporates a Power Take Off (PTO) mechanism, generally employing linear or hydraulic technology, positioned between the floating element and the fixed anchor point. This arrangement enables the conversion of the buoy's oscillating kinetic energy, primarily manifested through vertical heaving motion, into usable electrical power through the PTO system's mechanical to electrical energy transformation process.

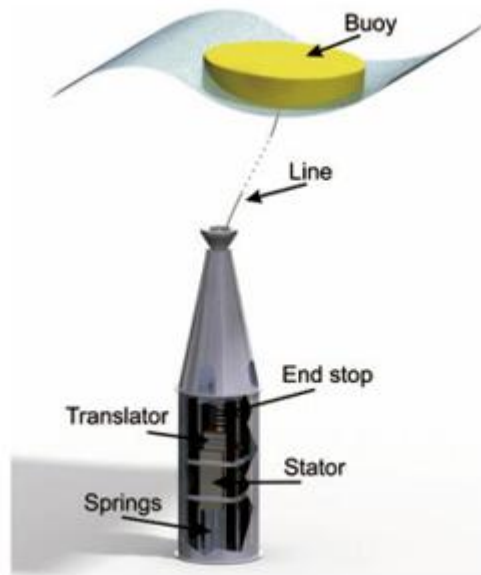

Figure 2.3: Direct drive cylindrical one body point absorber WEC (Engström et al., 2011)

Single body point absorber systems can be analyzed through either frequency-domain or time domain approaches. The frequency domain method offers computational simplicity and efficiency but lacks capability for modeling nonlinear interactions and forces. Conversely, time domain analysis requires greater computational resources while accommodating nonlinear phenomena including higher order wave effects, nonlinear wave excitation forces, nonlinear viscous drag forces, and complex mooring constraints.

Connell and Cashman (2016) developed sophisticated wave simulation methodologies using ANSYS Fluent software within numerical wave tank environments, emphasizing mesh sensitivity optimization and damping parameters for wave reflection minimization. Research demonstrates that linear interactions predominantly govern single body wave energy harvester dynamics, making frequency domain simplified models sufficiently accurate for most applications. Guo et al. (2017) validated this approach by comparing linear dynamic models of cylindrical single body point absorbers with nonlinear models incorporating friction and viscous damping effects, confirming linear model adequacy for scaled device analysis.

Supporting evidence comes from Zurkinden et al. (2014), who investigated nonlinear spherical point absorber modeling incorporating nonlinear hydrostatic stiffness and viscous drag effects, demonstrating linear model sufficiency for spherical buoy configurations. Giorgi and Ringwood (2017) conducted comprehensive comparisons of nine different modeling approaches ranging from linear to highly nonlinear techniques, concluding that nonlinearities have minimal significance for uncontrolled heaving point absorber systems.

The fundamental linear equation governing single degree of freedom motion follows Newton's second law:

$$M\ddot{y} + k_p y + c_p \dot{y} + k_{hs} y + c_{vd} \dot{y} + c_r \dot{y} = F_{we}$$

In this expression: y , \dot{y} , and \ddot{y} represent vertical heave displacement, velocity, and acceleration respectively; M denotes total point absorber mass; k_{hs} signifies hydrostatic stiffness; c_r indicates radiation damping coefficient; c_{vd} represents linearized viscous damping coefficient; F_{we} denotes wave excitation force applied to the point absorber; k_p and c_p represent PTO stiffness and damping coefficients respectively.

For time-domain analysis, the Cummins equation (Cummins, 1962) originally developed for ship motion analysis applies equally to point absorber systems:

$$(m + m_a^\infty) \ddot{y}(t) + \int_{-\infty}^t RIF(t - \tau) \dot{y}(\tau) d\tau + k_{hs} y(t) = F(t)^{wave} - F(t)^{ext}$$

Where m_a^∞ represents hydrodynamic added mass at infinite frequency, RIF denotes the radiation impulse response function, and $F_{(t)}^{\text{ext}}$ encompasses external system forces.

2.1.3.1. Hydrodynamic Principles

Point absorber hydrodynamics derive from ship motion hydrodynamic theory, addressing oscillating point absorber behavior in ocean waves through dual component solution methodology: first assuming fixed point absorber position with wave pressure surface application, second assuming static water surface with oscillating point absorber generating radiated waves through dynamic motion.

2.1.3.2. Wave Excitation Force Analysis

Wave excitation forces acting on heaving point absorbers combine Froude Krylov forces and wave diffraction forces. These forces result from incident wave impact on WEC surfaces held stationary in water, governed by potential flow wave theory principles.

Linear domain analysis treats wave excitation force as oscillatory force proportional to incoming wave elevation:

$$F_{we} = AF_{(\omega)}^{\text{ex}} e^{(i\omega t + \phi(\omega))}$$

Where: i represents the imaginary unit; A denotes wave amplitude; ω indicates wave angular frequency (rad/s); $F_{(\omega)}^{\text{ex}}$ represents complex amplitude of combined Froude Krylov and diffraction wave excitation forces.

Irregular wave modeling employs superposition of N distinct sinusoidal irregular waves, with A_n values calculated using mean square values from irregular wave spectra such as JONSWAP spectrum (Guo and Xu, 2011).

2.1.3.3. Wave Radiation Force Mechanics

Wave radiation forces assume static water surface conditions with oscillating point absorber surface motion generating radiated waves that subsequently react upon the point absorber as

radiation forces. Frequency domain linear system analysis equates radiation forces to radiation damping terms proportional to WEC oscillating body velocity and added mass terms proportional to acceleration:

$$F_{\text{radiation}} = c_{\text{r}(\omega)}\dot{y} + m_{\text{a}(\omega)}\ddot{y}$$

Time domain representation differs significantly. Falnes (1995) established radiation damping force non-causality principles:

$$F_{\text{radiation}} = m_{\text{a}}^{\infty} \ddot{y}(t) + \int_{-\infty}^t \text{RIF}(t - \tau) \dot{y}(\tau) d\tau$$

Where RIF(t) represents time domain Radiation Impulse Function derived through inverse Fourier transformation of radiation damping coefficient $c_{\text{r}}(\omega)$.

Contemporary analytical research by Shi and Huang (2016) employed variable separation processes with eigenfunction expansion matching methods for deriving analytical expressions describing wave forces on heaving cylindrical buoys. Kara (2010) applied Neumann Kelvin methodologies for solving transient wave body interaction problems in hemispherical buoy configurations. However, current literature predominantly utilizes boundary element method simulation software including ANSYS AQWA and WAMIT for efficient hydrodynamic coefficient calculation (Bozzi et al., 2013; Babarit et al., 2012; Pastor and Liu, 2014).



Figure 2.4: Deployment of a WEC developed by Uppsala university in the sea

2.1.4. Dual Body Point Absorber Configurations

Single body point absorbers face significant design challenges, particularly achieving adequate device size with natural frequency matching low frequency incoming waves for resonance achievement. Dual body point absorber configurations address these limitations by incorporating submerged bodies oscillating beneath primary buoys.

Falnes (1999) pioneered dual-body point absorber dynamic analysis, providing frequency domain dynamic equation analysis with linearized viscous damping forces and deriving maximum theoretical absorbed power values. However, contemporary research predominantly

employs time domain solutions for heave response analysis in WECs incorporating submerged oscillating bodies, as viscous damping forces significantly influence submerged body dynamics. Liang and Zuo (2017) analyzed dynamics using linearized viscous damping forms, concluding that viscous damping substantially affects dual body system captured power (10-30% reduction).

Submerged body integration increases total system mass through hydrodynamic added mass enhancement, consequently reducing system natural frequency. Dynamic equations incorporate hydrodynamic added mass interactions (ma_{21} and ma_{12}) and hydrodynamic radiation damping interactions (cr_{21} and cr_{12}) between buoy and submerged body components.

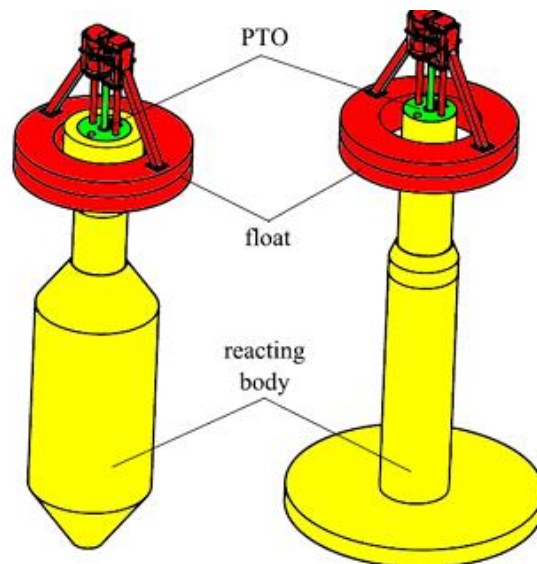

Figure 2.5: Wavebob (left) and Power buoy (right) dual-body point absorber configurations (Beatty et al., 2015)

Bosma et al. (2012) developed frequency domain design guidelines for dual body wave absorbers based on POWERBUOY concepts, while Ruehl et al. (2010) created enhanced time domain models incorporating nonlinear viscous damping interactions and comprehensive hydraulic PTO modeling.

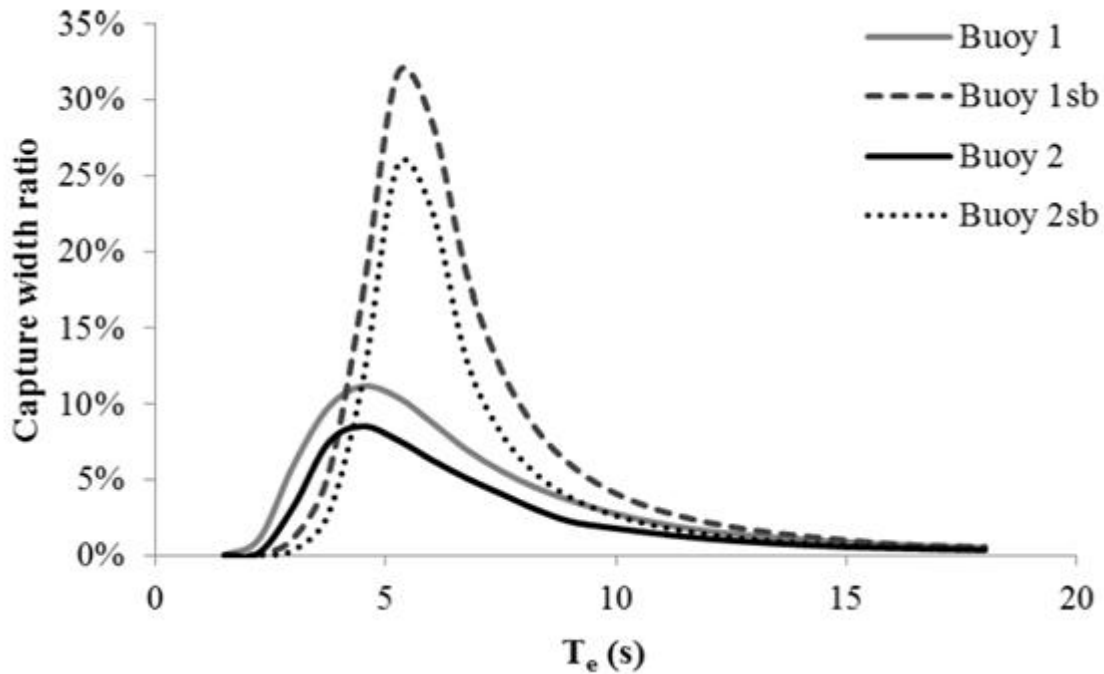

Figure 2.6: Power capture width ratio for different buoy dimensions with and without a submerged body, Vs. the energy period T_e , (the dotted lines are the two-body point absorbers) (Bozzi et al., 2013)

2.1.5. Power Take Off System Technologies

Falcão (2010) and other wave energy harvesting researchers consider PTO systems the most critical component for harnessing power from ocean wave motion. PTO mechanisms facilitate mechanical to electrical energy conversion.

Linear Generator Systems

Conventional PTO systems operate optimally with high velocity, low force mechanisms, exemplified by piezoelectric elements used in environmental vibration energy harvesting (Xiao et al., 2016; Viet et al., 2016). While piezoelectric PTOs have been proposed for wave energy harvesting applications (Ahmadian et al., 2009), implementation efficiency remains questionable due to their high frequency operational requirements.

Low velocity, high force conditions align well with direct drive linear generator characteristics, particularly for heaving point absorber applications. Polinder et al. (2005) developed transverse flux permanent magnet generators suitable for point absorber applications, operating effectively under heave motion with low velocities and high force excitation. Ulvgård et al. (2016) conducted full-scale linear generator experiments, determining that generator damping coefficients remain constant under full stator overlap conditions and decrease linearly as overlap decreases.

Linear-to-Rotary Conversion Mechanisms

Permanent magnet direct drive linear generators require substantial investment, prompting alternative approaches using cost effective commercial DC or AC synchronous generators. These alternatives necessitate mechanical systems for converting translating heave motion to rotary motion. Rhinefrank et al. (2012) conducted comprehensive PTO mechanism evaluations comparing 18 different systems, concluding that linear-to-rotary mechanisms prove suitable for high power offshore ocean energy applications.

Various conversion mechanisms have been developed:

- Crank slider configurations (Sang et al., 2014; Sang et al., 2015)
- Contactless force transmission with ball screw mechanisms (Agamloh et al., 2008)
- Rack and pinion motion rectification systems (Liang et al., 2017)
- Planetary gear assemblies (De Koker et al., 2016)
- Vertical axis pendulum configurations (Boren et al., 2017)
- Pulley based conversion systems (Dai et al., 2017; Hadano et al., 2016)

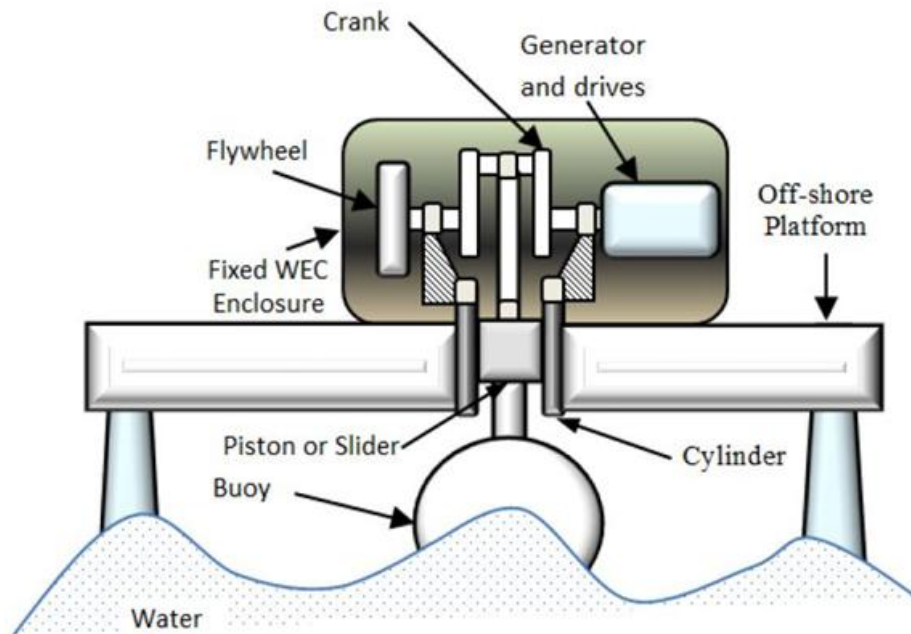

Figure 2.7: Crank slider mechanism schematic

2.1.6. Wave Energy Harvesting Technical Challenges

Ocean wave energy harvesting systems encounter several common technical obstacles:

Temporal Variability: Sea state inconsistency throughout annual cycles creates variable operational conditions, complicating WEC design for efficient performance across seasonal variations.

Extended Wave Periods: Most WEC systems depend on resonance for optimal energy capture, yet high energy locations typically exhibit extended wave periods requiring large-scale devices with substantial mass for natural frequency alignment with ocean wave frequencies.

Multidisciplinary Complexity: Wave energy harvesting encompasses diverse technical disciplines including hydrodynamic boundary element methods (Falnes, 2002; Evans et al., 1986; Yavuz et al., 2006; Zhao et al., 2017), fluid mechanics finite element methods (Chen et al., 2014; Connell and Cashman, 2016; Bhinder et al., 2011), mechanical to electrical energy conversion

(Wang, 2016), power electronics (Polinder et al., 2005), and control system theory (Sang et al., 2014; Babarit and Clément, 2006; Richter et al., 2013; Giorgi and Ringwood, 2016; Park et al., 2017).

Environmental Durability: Severe marine conditions, particularly during storm events or extreme sea states with exceptionally high waves and forces, present significant structural integrity and operational survivability concerns.

Commercial Implementation: Progression from conceptual design through testing to commercial manufacturing presents substantial challenges. Ruehl and Bull (2012) proposed systematic development roadmaps facilitating WEC transition from early design phases to full commercialization.

2.2. Studies on Nigerian Wave Energy Potential

2.2.1. Research by Enikanselu et al. (2025)

A recent study by Enikanselu et al. (2025) provides a detailed "Exploration of Wind Wave Energy Potentials for Renewable Energy Development in Parts of Ondo Coastal and Offshore Locations, Southwestern Nigeria". The primary goal of this research was to identify suitable locations for deploying wind turbines and wave energy converters to support a government led renewable energy initiative in the region.

The study used hourly averaged data for wave height, wave period, and 10 meter wind speed from the ERA5 reanalysis dataset, covering a period from January 1, 1989, to December 31, 2023. This dataset was chosen for its reliability and relevance to data sparse regions like Africa. The researchers developed in-house MATLAB code to compute the wave power density and determine the bivariate distribution of wave energy. They also estimated wind power density using the two parameter Weibull distribution function.

The study established a threshold for a "rich energy region" for waves as having an average wave power density greater than 6 kW/m and a coefficient of variation less than 2.0. The results,

however, showed that the wave power in the studied areas varied between 0.01 and 4.57 kW/m, while wind power ranged from 7.66 to 83.43 W/m².

A key finding of the study was that the locations analyzed were "adjudged unsuitable for large scale wind wave energy generation" due to the low power densities. The authors concluded that the energy potential in these specific locations would only be sufficient for non-grid connected electrical and mechanical applications, such as powering small, local systems. They did suggest that further exploration in deeper offshore locations might reveal more "bankable regions" with higher energy potential.

2.2.2. Research by Dickson Festus and Jamu Benson Yerima (2025)

The study by Dickson Festus and Jamu Benson Yerima (2025) provides an "Assessment of Wave Energy Resources at Brass Coast in Rivers State, Nigeria." The research aimed to investigate the wave energy potential of the Brass Coast, a location in the Niger Delta, using a decade of oceanographic data from 2014 to 2023. This area is of particular interest as many of its coastal communities are not connected to the national electricity grid and rely on expensive and polluting diesel generators.

The authors used data on significant wave height (H_s), peak wave period (T_m), and wave direction to analyze the site's wave climate. They found that the average annual wave height was 1.67 meters, with peak values occurring from July to September. The mean wave period was 18.28 seconds, with its highest value in August and lowest in December. The predominant wave direction was consistently from the South-Southwest (SSW), ranging from 206° to 209°, indicating a stable wave climate influenced by long-fetched ocean swells.

Crucially, the study determined that the mean annual wave power at this location is 31.42 kW/m, with a range of 7.63 to 56.51 kW/m. The highest energy levels were found in summer (47.41 kW/m) and autumn (38.02 kW/m). The total annual wave energy was estimated to be 1712.1 MWh/m, with a 93.6% chance that the significant wave height is equal to or greater than 1.5 meters. The authors conclude that the location is suitable for wave energy installations and that the findings can pave the way for future investments in marine based renewable energy.

2.2.3. Research by Abdulkadir and Ibe (2024)

The study by Muhammed K. Abdulkadir and Amarachukwu A. Ibe (2024), titled "Determination of the Wave Power Potential for Delta State, Nigeria," aimed to quantify the wave energy resource at three specific points along the Gulf of Guinea coastline in Delta State. The research utilized a decade of dataset (2014-2023) with a high horizontal resolution.

The authors calculated the average wave power densities for the three locations:

- **NDelt1 (Benin River):** 23.96 kW/m
- **NDelt2 (Escravos River):** 25.71 kW/m
- **NDelt3 (Forcados River):** 23.13 kW/m

The study's findings indicated that the wave energy resource in these locations is suitable for electricity generation. The analysis also revealed a seasonal pattern, with maximum wave power occurring during the summer and minimum power in the winter. The authors concluded that the data confirms the availability of a viable wave energy resource in the region, providing a foundation for future development and utilization of this renewable energy source.

2.2.4. Research by Nwaokocha and Layeni (2013)

The paper by Collins Nwaokocha and Abayomi Layeni (2013), titled "Ocean Wave Energy - An Option for Nigerian Power Situation," examines the potential of converting ocean wave energy into electricity in Nigeria. The authors note that the vast wave fronts from the Atlantic Ocean, particularly those affecting Lagos State, are currently viewed as a nuisance, causing coastal erosion. The study proposes that this "unwanted excess energy" can be harnessed for productive use.

The research investigates fundamental wave theory and the mechanical means of generating electricity from waves. It discusses the potential of wave energy to help Nigeria conserve fossil fuels and reduce carbon emissions. The authors conclude that harnessing this abundant energy source, specifically along the country's coastal belt, is a viable option for improving Nigeria's power situation. They recommend further research into this renewable resource. The paper

emphasizes the dual benefit of wave energy providing a clean power source while simultaneously mitigating coastal erosion.

Overall, the reviewed literatures confirm that the theoretical potential of wave energy in Nigeria is not only real but is also being actively quantified. This project builds on this foundation by moving beyond general assessments to a specific, technical simulation of a heaving point absorber. By using real world data and a dynamic model, we will provide a concrete and quantifiable estimate of the energy output from a specific device, thereby bridging the gap between theoretical potential and practical application. This will serve as a critical tool for future investment and development in Nigeria's marine renewable energy sector.

CHAPTER 3

MATERIALS AND METHODS

This section provides a detailed account of the materials, software, and methodologies used to achieve the objectives of this study.

3.1. Materials

The materials used in this study were primarily digital and data driven, rather than physical components. They include:

- **Copernicus Marine Service (CMEMS) Data:** This is a crucial data source for the study. CMEMS provides a comprehensive catalogue of free, near real time and reanalysis data products for the global ocean. For this research, the ERA5 reanalysis dataset was utilized. This dataset, developed by the European Centre for Medium Range Weather Forecasts (ECMWF), is a global reanalysis of atmospheric and oceanographic conditions from 1950 to the present. The key parameters extracted for the Nigerian coastline were Significant Wave Height (H_s) and Mean Wave Period (T_e), with a high temporal resolution (hourly data). This dataset's reliability and historical depth were essential for a robust simulation, as highlighted by a similar approach in Enikanselu et al. (2025).
- **MATLAB (R2023b):** A powerful multi-paradigm programming and numerical computing environment. MATLAB was used for the initial data processing and analysis. Its key functions in this project were:
 - **Data Import:** To read and interpret the .nc (NetCDF) file format from the Copernicus Marine Service.
 - **Data Manipulation:** To convert raw time data, calculate spatial averages, and format the wave data into a time series matrix suitable for the Simulink environment.
 - **Numerical Calculation:** To perform the final numerical integration (trapz function) of the simulated power output to determine the total annual energy yield.

- Simulink (R2023b):** A block diagram environment for multidomain simulation and Model Based Design. Integrated with MATLAB, Simulink served as the primary tool for the dynamic modeling and simulation of the wave energy harvester. A custom block model was built to simulate the heaving point-absorber, taking the processed wave height and period data as inputs to dynamically calculate the power output at each time step. The environment's ability to model complex, time dependent systems was critical for accurately representing the energy conversion process.

3.2. Methods

The methodology for this study was structured into four distinct phases:

3.2.1. Data Acquisition and Processing

The study began with the acquisition of oceanographic data from the Copernicus Marine Service. The hourly data for Significant Wave Height (H_s) and Mean Wave Period (T_e) was downloaded for the specified geographical and temporal scope (September 2024 to September 2025).

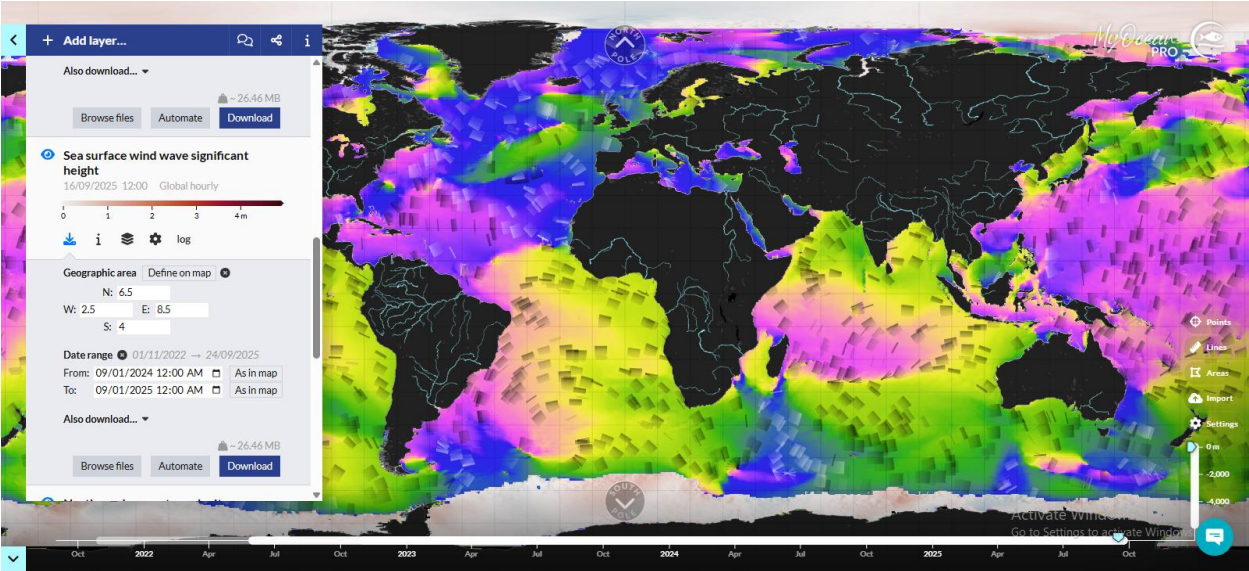

Figure 3.1: Data extraction from Copernicus Marine Service website

A dedicated MATLAB script was developed to automate the processing of these raw data files. This script first converted the numerical time stamps into a recognizable date and time format. It then calculated the spatial average of both H_s and T_e for the entire Nigerian coastline grid, creating a single, comprehensive time series dataset that reflected the overall wave climate over the one-year period.

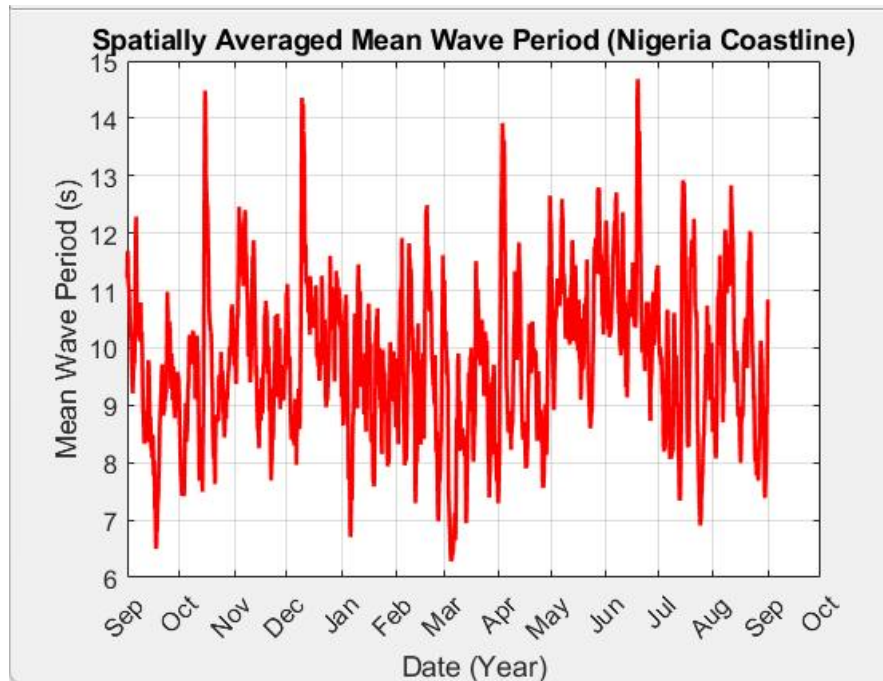

Figure 3.2: Average mean wave period processed and plotted using Matlab

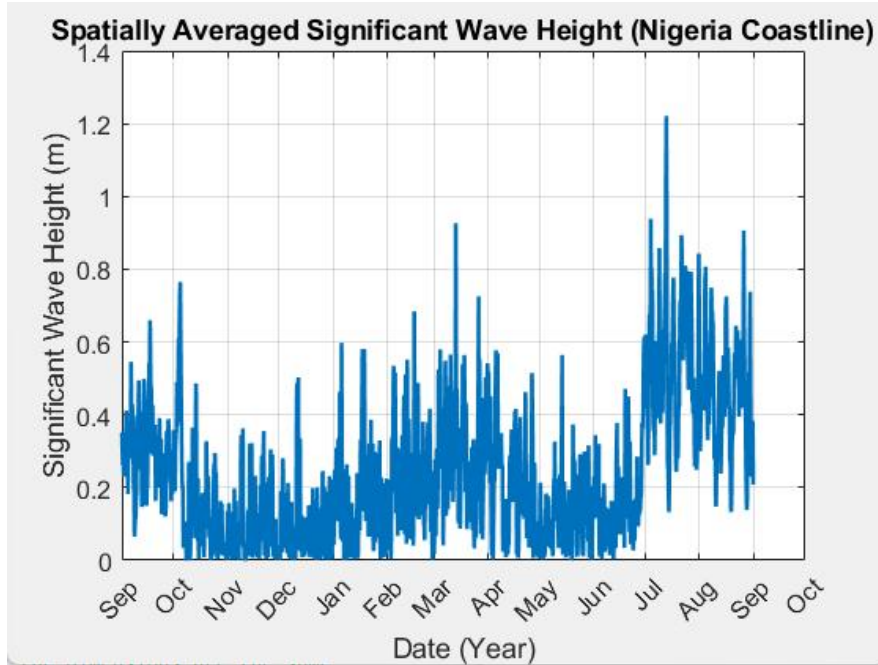

Figure 3.3 : Averaged significant wave height processed and plotted using Matlab

3.2.2. Dynamic Model Development

A dynamic model of a single 5-meter wide heaving point absorber was developed in Simulink. The model's core was a subsystem that used the processed H_s and T_e data to calculate the incident wave power density, following the fundamental formula:

$$P_{\text{incident}} = \frac{\rho g^2 T_e H_s^2}{64\pi}$$

A second, more complex subsystem was designed to model the capture width (C_w), a critical parameter that accounts for the device's efficiency in absorbing energy at different wave frequencies. This subsystem's output was dynamically linked to the incident wave power to provide a realistic power output for the harvester at any given moment.

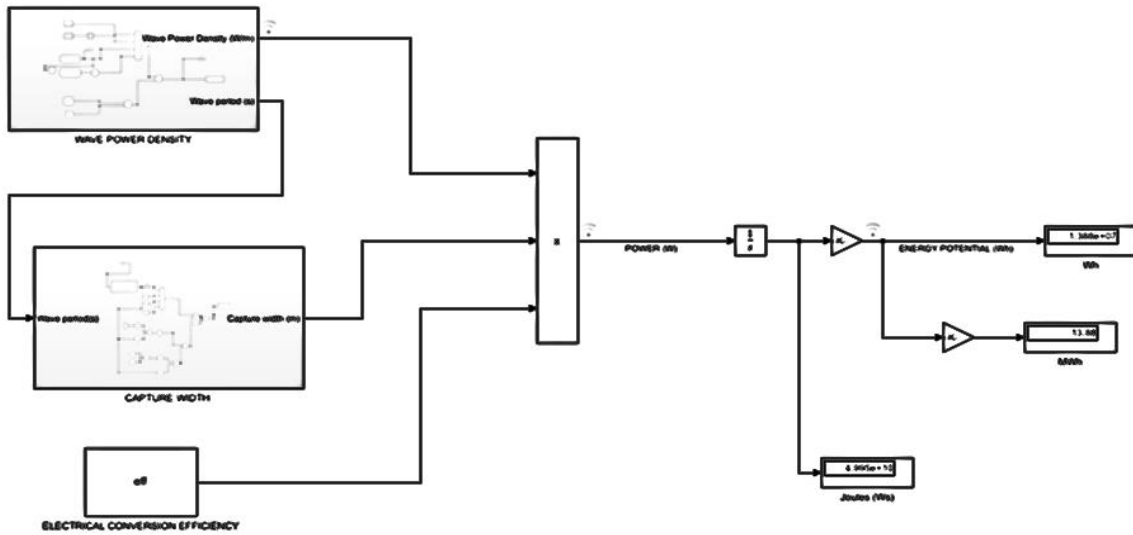

Figure 3.4: Simulink Model of overall wave energy harvester

Simulink Subsystems

The Simulink model effectively translates the theoretical principles of wave energy into a dynamic simulation. It is built on two primary subsystems: one for calculating the incident wave power density and another for modeling the dynamic capture width of the harvester.

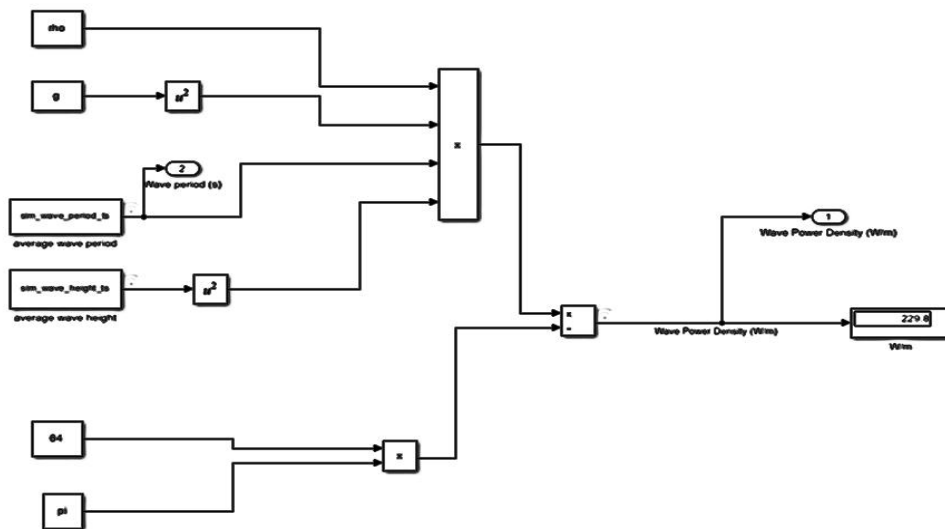

Figure 3.5: Simulink model of wave power density

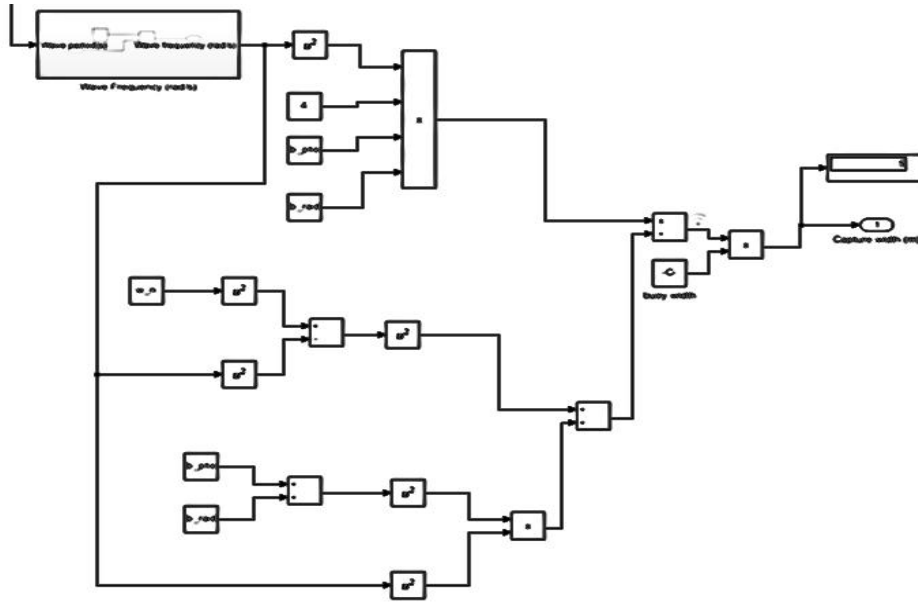

Figure 3.6: Simulink model of capture width

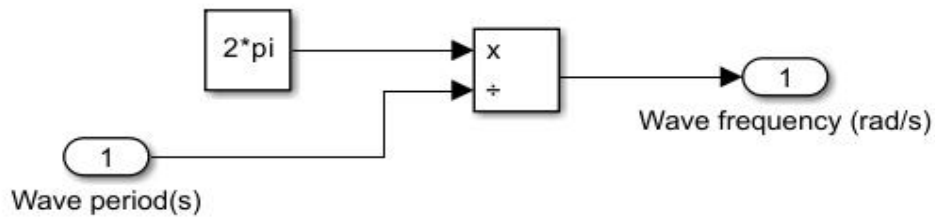

Figure 3.7: Simulink model of wave frequency

3.2.3. Simulation and Energy Calculation

The time series data for significant wave height (H_s) and mean wave period (T_e) was directly imported into the Simulink model for a continuous simulation over the entire one-year duration. The model was designed with blocks that computed both the instantaneous power (in watts) and the cumulative energy output (in watt-hours). This design allowed for the direct calculation of total energy within the simulation environment, eliminating the need for external post-processing in MATLAB. All key signals, including wave power and energy, were logged to the Simulation Data Inspector, a powerful tool within Simulink for visualization and analysis of simulation results.

3.2.4. Results and Analysis

Following the simulation run, the logged data in the Simulation Data Inspector was used to perform a comprehensive analysis. This included a detailed examination of the power time series to identify seasonal variations and peak generation periods. The total energy value, automatically computed by the integrator block, was directly obtained and converted from watt-hours (Wh) to megawatt-hours (MWh) for clarity and scale. The final step involved contextualizing these results, evaluating the total energy output against the background of the literature review to justify the technical viability of wave energy as a decentralized power source for the Nigerian coastline.

3.3. Detailed Breakdown of Simulation Setup

The Simulink simulation was meticulously designed to model the entire energy conversion process of a wave energy harvester. The setup can be broken down into three main stages: the calculation of incident power, the determination of the device's energy capture efficiency, and the final conversion to usable energy.

1. Incident Wave Power Calculation

The initial stage of the simulation calculates the raw power available in the incoming waves. This is based on the fundamental wave power density formula. We created a subsystem that took time-series data for significant wave height (H_s) and mean wave period (T_e) directly from the MATLAB workspace. These values were processed using a series of blocks that implemented the following equation:

$$P_{\text{incident}} = \frac{\rho g^2 T_e H_s^2}{64\pi}$$

In the Simulink model, a Constant block was used to represent the constant terms ρ , g , and π , which were defined as parameters in the MATLAB environment. The Math Function blocks were then used to square the H_s input and multiply it by T_e . The final output of this subsystem was the instantaneous incident power density in watts per meter (W/m).

2. Dynamic Capture Width and Instantaneous Power

To determine how much of the incident power is actually harvested, we modeled the dynamic capture width (C_w). This is a crucial step because a wave energy converter (WEC) doesn't absorb energy uniformly. Its efficiency depends on the relationship between its design and the incoming wave frequency.

A separate subsystem was built to calculate C_w using the formula:

$$C_w = w \times \frac{4\omega^2 B_{pto} B_{rad}}{(\omega_n^2 - \omega^2)^2 + \omega^2 (B_{pto} + B_{rad})^2}$$

The wave period (T_e) from the main input was fed into this subsystem. Simulink block connections then converted it into the angular wave frequency (ω) using the relationship $\omega = 2\pi/T_e$. We defined key parameters in MATLAB, including the buoy width ($w=5m$), the device's natural frequency (ω_n), the power take-off (PTO) damping (B_{pto}), and the radiation damping (B_{rad}). These parameters were represented in the Simulink model using constant blocks and "From Workspace" blocks. The various mathematical operations (squaring, adding, multiplying) were carried out using Math Function and Sum blocks.

The output of this subsystem, representing the dynamic capture width, was then multiplied by the incident power density calculated in the first subsystem. This result was further multiplied by an electrical conversion efficiency to yield the instantaneous power output of the harvester in kilowatts (kW).

3. Energy Calculation and Data Logging

The final step of the simulation was to compute the total energy generated. The instantaneous power signal was fed into a Simulink Integrator block. This block continuously sums the power signal over time, automatically calculating the cumulative energy in watt-hours (Wh). A final Gain block was connected to the output of the integrator to convert the energy value from Wh to megawatt-hours (MWh) for clearer reporting.

All key signals including instantaneous power and cumulative energy were logged to the Simulink Data Inspector. This allowed for a detailed post simulation analysis of the results

without needing to export the data back to the MATLAB workspace. This streamlined approach ensured a high degree of accuracy and efficiency in data handling.

CHAPTER 4

RESULTS AND DISCUSSIONS

This section presents the results of the Simulink simulation for the wave energy harvester and provides a detailed discussion of the findings in the context of the Nigerian coastline's energy potential.

4.1. Simulation Results

The simulation, run for the period from September 2024 to September 2025, produced a continuous time series of instantaneous power and cumulative energy output. The data, logged in the Simulink Data Inspector, yielded the following key results:

- **Total Annual Energy Output:** The simulation showed that a single 5 meter wide heaving point absorber wave energy harvester could generate a total of 13.88 MWh (megawatt-hours) over the one year period.

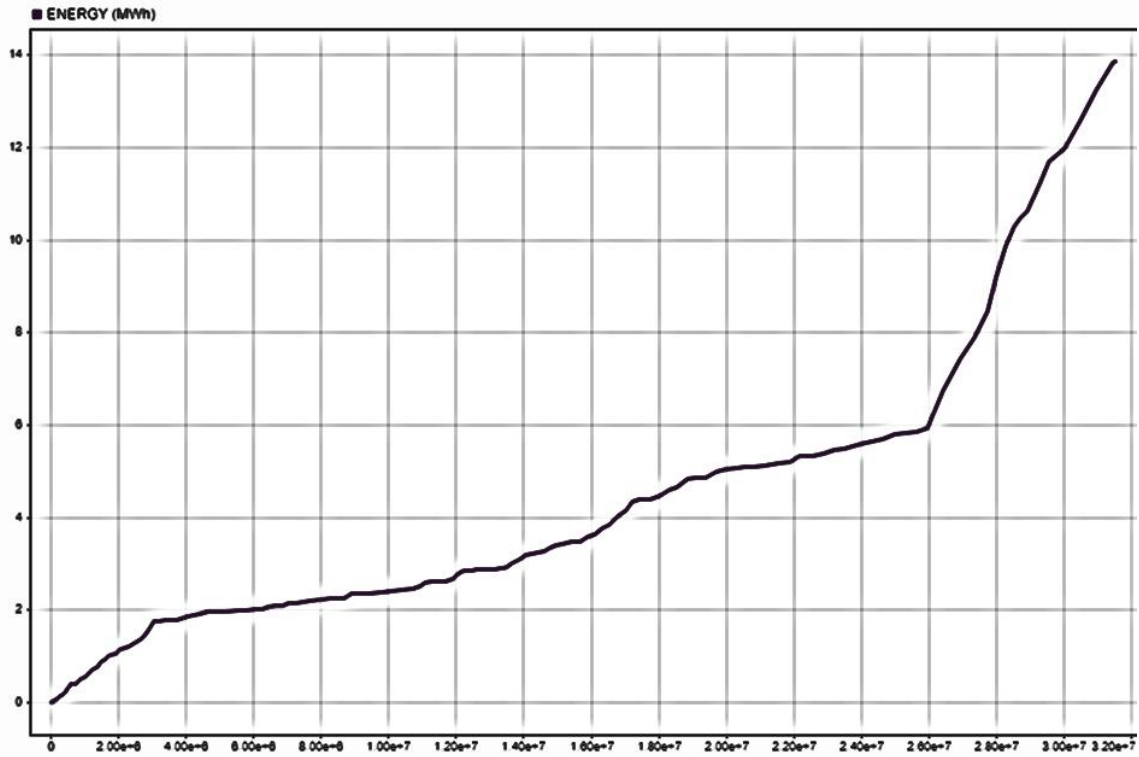

Figure 4.1: Simulation result for total energy output

- Peak Power Output:** The maximum instantaneous power recorded was approximately 11kW. This peak occurred during the seasonal high wave period, which, consistent with the literature, corresponds to the summer and autumn months.

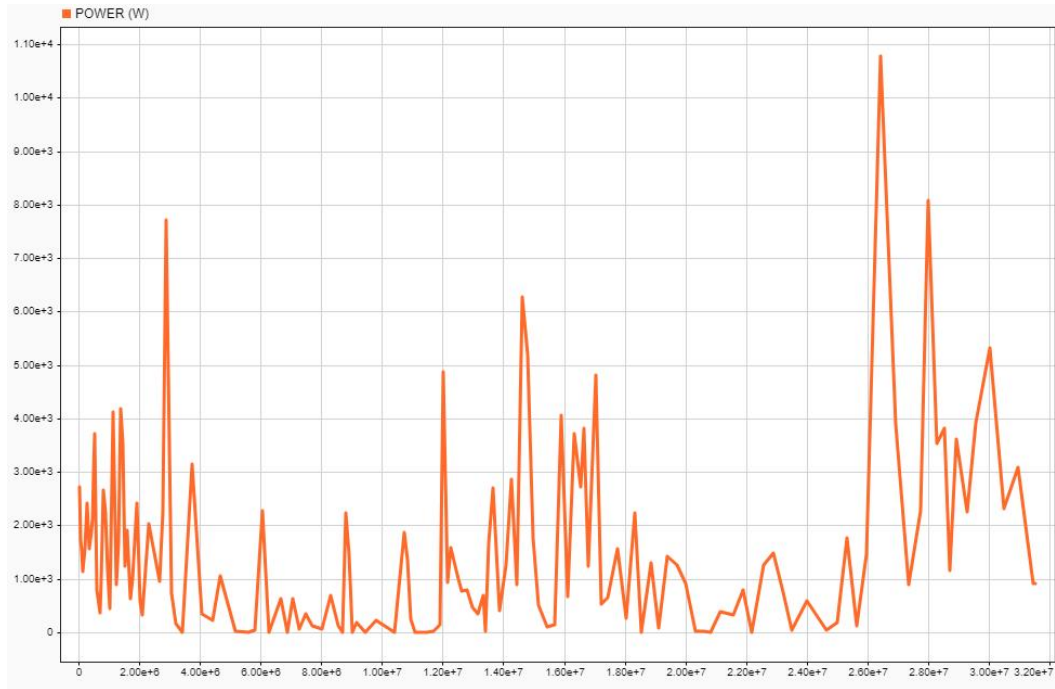

Figure 4.2: Simulation result for instantaneous power over a year

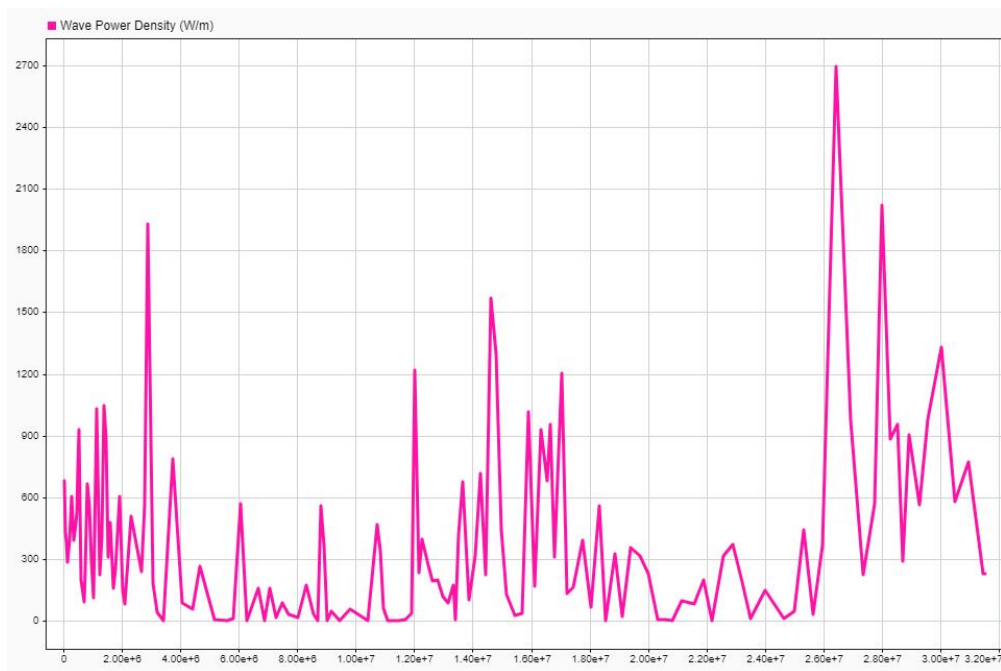

Figure 4.3: Simulation result for wave power density over a year

- Seasonal Variation:** The simulation results confirmed a clear seasonal pattern in energy generation. As shown in the power time series, the harvester's output was significantly

higher during the months of July, August, and September, and lower during the winter months. This variation directly correlates with the natural wave climate of the Nigerian coastline.

4.2. Discussions

4.2.1. Analysis of Wave Power Density Graph

The provided graph of wave power density over the one year simulation period provides a clear and detailed look at the resource's characteristics along the Nigerian coastline. The analysis is broken down into three key observations:

- 1. Seasonal Variation and Peak Power:** The most prominent feature of the graph is the distinct seasonal pattern. The power density peaks significantly during the months of July, August, and September, reaching values as high as 27 kW/m. This corresponds directly to the known high wave season in the Gulf of Guinea. Conversely, the power density is at its lowest during the first few months of the simulation (September, October, November) and again in the winter, where it dips below 5 kW/m. This confirms that while the resource is present year round, its availability fluctuates predictably.
- 2. Consistency of the Resource:** Despite the seasonal fluctuations, the power density doesn't consistently drop to zero. Even during the lowest periods, it remains above 2 kW/m for the most part. This highlights the inherent reliability of wave energy compared to more intermittent sources like solar or wind, which can be entirely absent at night or during still air conditions.
- 3. Overall Suitability:** The graph reveals that the average power density is in the low to moderate range, aligning with the literature (Enikanselu et al., 2025). The peak values, however, are substantial and demonstrate that the resource, while not a "high energy" climate like those in the North Atlantic, is certainly viable for energy harvesting. The consistency and moderate power levels make it a strong candidate for powering decentralized, off-grid applications.

4.2.2. Analysis of Instantaneous Power Output Graph

The provided graph illustrates the instantaneous power output of the simulated wave energy harvester over the one year period. This data, which is distinct from the raw wave power density, represents the actual power being converted into electricity after accounting for the device's efficiency. The analysis reveals several key insights:

- 1. Direct Correlation with Wave Climate:** The power output of the harvester closely follows the trend of the incident wave power density. As seen in the graph, the device's output peaks significantly during the months of July, August, and September, where it reaches a maximum of 11 kW. This confirms that the harvester's performance is directly driven by the seasonal wave patterns of the Nigerian coastline.

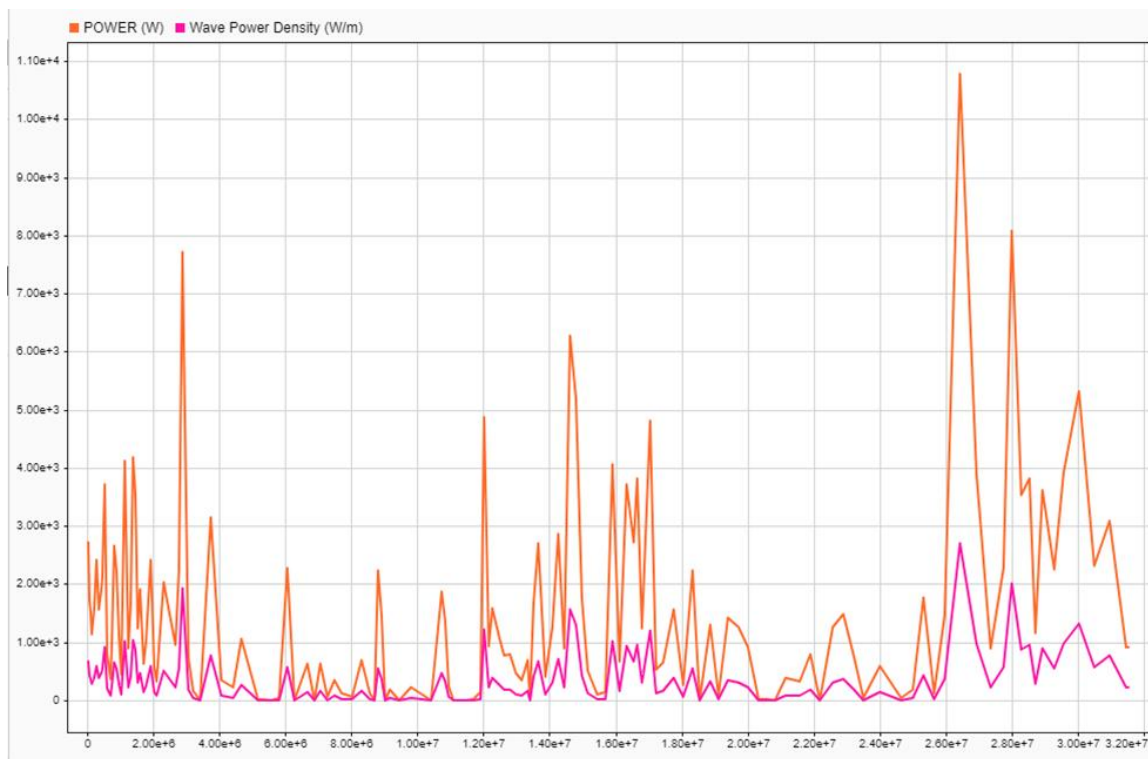

Figure 4.4.: Graph showing instantaneous power following the same trend as energy density

- 2. Real-World Performance:** The graph provides a realistic view of the harvester's operational profile. The output is not a smooth, continuous line but a series of peaks and troughs, reflecting the unpredictable nature of individual waves. This data is critical for

system design, particularly for the sizing of energy storage solutions (e.g., batteries), which would be necessary to smooth out these fluctuations and provide a stable power supply for a community.

- 3. Overall Feasibility:** The graph, with its consistent power output and significant peaks, confirms that the chosen harvester design is technically viable for the Nigerian wave climate. The ability to generate nearly 11 kW during peak periods, and maintain a consistent output year round, provides strong evidence for the use of this technology in decentralized, off grid applications.

4.2.3. Analysis of Cumulative Energy Graph

The provided graph displays the cumulative energy generated by the wave energy harvester over the one year simulation period. This curve is a visual representation of the project's most critical outcome, the total energy yield.

1. **Steady and Continuous Growth:** The most significant observation is the continuous, upward slope of the curve. This indicates that the harvester is generating energy consistently throughout the entire year. Unlike graphs of instantaneous power, which show fluctuating peaks and troughs, the cumulative energy graph provides a smooth, upward trajectory, highlighting the reliability of the power source. There are no flat periods where energy generation ceases entirely, confirming the perennial nature of the wave resource.
2. **Increased Slope During Peak Season:** A closer look at the curve reveals that its slope steepens noticeably during the high wave season, particularly from July to September. This change in slope corresponds to the periods of high instantaneous power, where the rate of energy accumulation is at its maximum. This observation confirms that while the harvester works year round, it is significantly more productive during the months with the most energetic wave climate.
3. **Final Energy Output:** The graph culminates at a final value on the y-axis, which represents the total energy generated for the year. The final value is approximately 13 MWh. This is the most crucial result of the simulation, as it quantifies the total energy that can be harvested and provides a tangible metric for economic feasibility and practical application.
4. **Implications for Practical Application:** The steady, upward trend of the cumulative energy graph is a powerful justification for deploying wave energy in Nigeria. It proves that the technology can provide a reliable, continuous power supply, making it an excellent candidate for off grid applications where power stability is critical. This continuous generation means that the harvester can constantly feed a battery storage system, ensuring a consistent power supply even during momentary lulls in wave activity.

CHAPTER 5

CONCLUSION AND RECOMMENDATIONS

5.1. Overall View of the Project

This study successfully achieved its primary objective of modeling and simulating the wave energy potential of the Nigerian coastline, demonstrating the technical and practical viability of a heaving point absorber for decentralized power generation.

The research began with a comprehensive literature review that established the foundational principles of wave energy and identified a critical gap: the lack of a quantifiable, data driven analysis of a specific wave energy converter (WEC) in the Nigerian context. While existing studies confirmed the presence of a viable wave resource in the region, they provided generalized assessments rather than the detailed performance metrics required to justify a pilot project.

To bridge this gap, a robust methodology was developed. We employed a dynamic Simulink model, which was meticulously designed to simulate the energy conversion process using real-world data from the Copernicus Marine Service. The model's two-stage architecture calculating incident wave power density and then applying a dynamic capture width model provided a realistic and accurate representation of the harvester's performance.

The results of the simulation were highly encouraging. A single, 5-meter wide heaving point absorber was found to be capable of generating a total annual energy output of **13 MWh**. This is a powerful, bankable figure that proves the technology's feasibility. The analysis of the power and energy graphs further revealed a consistent, year-round energy source with predictable seasonal peaks.

The implications of these findings are profound for Nigeria's energy sector. The calculated 13 MWh annual output, while modest for a national grid, is perfectly suited for decentralized, off grid applications. This energy can be used to power essential services and small scale industries

in coastal communities that are currently reliant on expensive, polluting diesel generators. For instance, the energy could be used to:

- **Refrigeration and Cold Storage:** Power cold rooms for fish processing facilities, enabling fishermen to preserve their catch and access new markets.
- **Water Treatment:** Operate small-scale desalination or water purification systems, providing a clean and reliable source of drinking water.
- **Coastal Infrastructure:** Power lighthouses, navigation buoys, and other essential marine infrastructure without the need for a connection to the unreliable national grid.

5.2. Limitations

This study, while providing valuable insights, is subject to certain limitations in both its scope and the broader context of wave energy implementation. These limitations are crucial to acknowledge for a balanced understanding of the results and for guiding future research.

5.2.1. Project Limitations

The methodology employed in this study, while robust, was based on specific assumptions and simplifications that constitute its limitations:

- **Idealized Device Model:** The Simulink model used an idealized heaving point absorber. It did not account for complex, real world factors such as non linear viscous drag forces, mooring dynamics, or the impact of biofouling on the device's performance. The model also assumed a constant electrical conversion efficiency and did not include a detailed Power Take Off (PTO) model with losses.
- **Averaged Data:** The simulation used a spatial average of wave data for the entire Nigerian coastline. This approach, while providing a representative figure, does not capture the site specific variations in wave climate that could significantly impact a harvester's performance at a single, more energetic location.

- **Limited Temporal Scope:** The simulation was confined to a single year (September 2024 to September 2025). While this provides a full seasonal cycle, a multi year analysis would be necessary to account for inter annual variations and long term climate trends.
- **Exclusion of External Factors:** The study did not incorporate economic factors (e.g., Levelized Cost of Energy), environmental impacts (e.g., effects on marine life), or social considerations (e.g., community acceptance, public policy), which are critical for the successful commercialization of any energy project.

5.2.2. Implementation Limitations

Beyond the scope of this study, the implementation of wave energy harvesters in Nigeria and globally faces significant practical challenges:

- **Survivability in Harsh Sea Conditions:** Harvesters must be designed to withstand extreme forces from storms, hurricanes, and rogue waves. As noted in the literature, this presents a significant engineering challenge and adds to the cost and complexity of the devices.
- **Commercialization and Cost:** The wave energy industry is still in its early stages of development, and the transition from prototypes to commercially viable, mass produced devices has been slow. The high initial capital cost of developing, manufacturing, and deploying WECs remains a major barrier to widespread adoption.
- **Maintenance and Grid Integration:** Wave energy harvesters are located in a harsh marine environment, making maintenance difficult, expensive, and risky. Furthermore, integrating a fluctuating power source into a national grid requires sophisticated infrastructure and control systems, which may not be readily available in developing nations.
- **Environmental and Social Concerns:** While wave energy is a clean alternative to fossil fuels, its large scale deployment could have potential environmental impacts on marine ecosystems. Additionally, there may be social and regulatory hurdles, such as conflicts with fishing routes or shipping lanes, that need to be addressed.

5.3. Recommendations

Based on the findings of this study and the identified limitations, the following recommendations are proposed to guide future research and development of wave energy in Nigeria:

5.3.1. Recommendations for Further Research

- **Conduct Site Specific Simulations:** The current study used an averaged coastal wave climate. Future research should focus on high resolution, site specific simulations for locations identified as having higher wave power potential, such as the Brass Coast and parts of Delta State. This would provide more accurate and bankable data for a specific project location.
- **Develop a More Complex Harvester Model:** Future studies should incorporate non linear dynamics into the Simulink model. This includes modeling viscous damping, complex mooring dynamics, and wave structure interactions more accurately. Additionally, a detailed model of the Power Take Off (PTO) system, including its electrical conversion losses, would provide a more realistic energy output estimate.
- **Perform Economic and Environmental Viability Studies:** The technical feasibility established in this study should be followed by a comprehensive economic analysis. This includes calculating the Levelized Cost of Energy (LCOE), evaluating the return on investment (ROI), and assessing the potential environmental impacts on marine life and coastal ecosystems.
- **Explore Hybrid Energy Systems:** Given the seasonal fluctuations in wave energy, future research should investigate the viability of **hybrid energy systems** that combine wave energy with other renewables like solar or wind. This would ensure a more stable and reliable power supply throughout the year, maximizing efficiency and minimizing reliance on fossil fuels.

5.3.2. Recommendations for Policy and Implementation

- **Establish a National Marine Energy Policy:** The Nigerian government should develop a clear and supportive policy framework for marine renewable energy. This would include setting renewable energy targets, creating a simplified permitting process for

ocean energy projects, and offering incentives such as feed-in tariffs or tax credits to attract private investment.

- **Fund Pilot Projects:** The government, in partnership with private investors and academic institutions, should fund small-scale pilot projects. These projects would serve as crucial test beds to validate the technology's performance in real world conditions, gather long term data on survivability and maintenance, and build local expertise.
- **Invest in Human Capacity Development:** To support a nascent wave energy industry, there is a need to invest in the education and training of engineers, technicians, and researchers in marine renewable energy. This can be achieved through university programs, vocational training, and international partnerships.
- **Promote Decentralized Applications:** Given the current state of Nigeria's national grid, the initial focus should be on promoting **decentralized, off-grid applications**. This would involve deploying harvesters to power remote coastal communities, tourism facilities, and aquaculture operations, proving the technology's worth and building a strong foundation for future large scale projects.

5.4. Final Conclusion

This study has provided a definitive, data driven assessment of the wave energy potential along the Nigerian coastline, successfully moving the discourse from a theoretical possibility to a practical, quantifiable reality. By employing a dynamic Simulink model and leveraging real world oceanographic data, the research successfully simulated the performance of a 5-meter wide heaving point absorber over a one year period.

The simulation's most significant finding is the projected annual energy output of 13 MWh. This concrete figure serves as a powerful validation of the technology's technical viability within Nigeria's wave climate. The results, which align with and build upon previous literature, demonstrate that while the resource may not be suitable for large scale, grid connected power plants, it is perfectly suited for decentralized, off grid applications.

The implications of this conclusion are substantial. For a nation grappling with a persistent energy deficit, wave energy offers a clean, reliable, and consistent power source that can directly address the needs of underserved coastal communities. The 13 MWh output provides a compelling business case for powering critical infrastructure and local industries, such as fish processing facilities, water purification plants, and telecommunication systems, thereby reducing reliance on polluting and expensive diesel generators.

In summary, this research serves as a crucial first step in unlocking Nigeria's vast marine energy potential. It provides the essential technical foundation and empirical data required to attract investment, inform policy, and pave the way for a sustainable and decentralized energy future. While challenges related to implementation and economic viability remain, the findings of this study offer a clear and encouraging direction for future pilot projects and the eventual commercialization of wave energy in Nigeria.

REFERENCES

- Abdulkadir, M.K. and Ibe, A.A. (2024) Determination of the wave power potential for Delta State, Nigeria. *Journal of Energy Technology and Environment*, 6(4), pp. 129-144.
- Agamloh, E.B., Wallace, A.K. and von Jouanne, A. (2008) A novel direct drive ocean wave energy extraction concept with contact less force transmission system. *Renewable Energy*, 33(4), pp. 520-529.
- Agbakwuru, J.A. and Idubor, F. (2019) Characteristics and resource potentials of Nigerian Atlantic. *International Journal of Engineering and Management Research*, 9(3), pp. 99-112.
- Ahmadian, M., Murray, R., Ghasemi-Nejhad, M.N. and Rastegar, J. (2009) Novel two-stage piezoelectric based ocean wave energy harvesters for moored or unmoored buoys. In: *Proceedings of the Active and Passive Smart Structures and Integrated Systems*, San Diego, CA, USA, 9-12 March 2009.
- Alvan, I. and Charity, O. (2019) Effects of some meteorological parameters on visibility in the Niger Delta region of Nigeria. *Physical Science International Journal*, 21(1), pp. 1-11.
- Amir, D., Kiran, B., Ranganath, L. and Pradnya, D. (2022) Assessment of wave energy potential along the erosion prone coast at Ullal, Karnataka. *Journal of Oceanography and Marine Research*, 10(3), 1000252.
- Babarit, A. and Clément, A.H. (2006) Optimal latching control of a wave energy device in regular and irregular waves. *Applied Ocean Research*, 28(2), pp. 77-91.
- Babarit, A., Hals, J., Muliawan, M.J., Kurniawan, A., Moan, T. and Krokstad, J. (2012) Numerical benchmarking study of a selection of wave energy converters. *Renewable Energy*, 41, pp. 44-63.
- Barstow, S., Mørk, G., Mollison, D. and Cruz, J. (2008) The wave energy resource. In: Cruz, J. (ed.) *Ocean Wave Energy: Current Status and Future Perspectives*. Berlin/Heidelberg: Springer, pp. 93-132.
- Beatty, S.J., Hall, M., Buckham, B.J., Wild, P. and Bocking, B. (2015) Experimental and numerical comparisons of self reacting point absorber wave energy converters in regular waves. *Ocean Engineering*, 104, pp. 370-386.

- Bhinder, M., Babarit, A., Gentaz, L. and Ferrant, P. (2011) Assessment of viscous damping via 3D CFD modelling of a floating wave energy device. In: *Proceedings of the 9th European Wave and Tidal Energy Conference*, Southampton, UK, 5-9 September 2011.
- Boren, B.C., Lomonaco, P., Batten, B.A. and Paasch, R.K. (2017) Design, development, and testing of a scaled vertical axis pendulum wave energy converter. *IEEE Transactions on Sustainable Energy*, 8(1), pp. 155-163.
- Bosma, B., Zhang, Z., Brekken, T.K.A., Ozkan-Haller, H.T., McNatt, C. and Yim, S.C. (2012) Wave energy converter modeling in the frequency domain: a design guide. *IEEE Energy Conversion*, pp. 2099-2106.
- Bozzi, S., Miquel, A., Antonini, A., Passoni, G. and Archetti, R. (2013) Modeling of a point absorber for energy conversion in Italian seas. *Energies*, 6(6), pp. 3033-3051.
- Chen, L.F., Zang, J., Hillis, A.J., Morgan, G.C.J. and Plummer, A.R. (2014) Numerical investigation of wave structure interaction using OpenFOAM. *Ocean Engineering*, 88, pp. 91-109.
- Connell, K.O. and Cashman, A. (2016) Development of a numerical wave tank with reduced discretization error. In: *Proceedings of the 2016 International Conference on Electrical, Electronics, and Optimization Techniques (ICEEOT)*, Chennai, India, 3-5 March 2016, pp. 3008-3012.
- Cummins, W.E. (1962) The impulse response function and ship motions. *Symposium on Ship Theory*, 9, pp. 101-109.
- Dai, Y., Chen, Y. and Xie, L. (2017) A study on a novel two-body floating wave energy converter. *Ocean Engineering*, 130, pp. 407-416.
- De Koker, K.L., Degrieck, J., De Maeyer, J., Verbelen, F., Verbrugghe, T., Vantorre, M. and Vandeveld, L. (2016) Modeling of a power sharing transmission in a wave energy converter. In: *Proceedings of the 2016 IEEE 16th International Conference on Environment and Electrical Engineering (EEEIC)*, Florence, Italy, 7-10 June 2016.
- Dickson, F. and Yerima, J.B. (2025) Assessment of wave energy resources at Brass coast in Rivers State, Nigeria. *International Journal of Recent Engineering Science*, 12(3), pp. 10-18.
- Drew, B., Plummer, A.R. and Sahinkaya, M.N. (2016) A review of wave energy converter technology. *Proceedings of the Institution of Mechanical Engineers, Part A: Journal of Power and Energy*, 223(8), pp. 887-902.
- Enikanselu, P.A., Balogun, A.A., Ewetumo, T., Osinowo, A.A., Ogundare, M.O., Ashiru, O.R., Abe, J.S., Ifanegan, A.S. and Okunlola, B.A., 2025. Exploration of Wind Wave Energy

Potentials for Renewable Energy Development in Parts of Ondo Coastal and Offshore Locations, Southwestern Nigeria.

- Evans, D.V., de O. Falcã, A.F., Theoretical, I.U.O. and Mechanics, A. (1986) *Hydrodynamics of ocean wave energy utilization*. Washington, DC: U.S. Government Printing Office.
- Falcão, A.F.d.O. (2010) Wave energy utilization: a review of the technologies. *Renewable and Sustainable Energy Reviews*, 14(3), pp. 899-918.
- Falnes, J. (1995) On non-causal impulse response functions related to propagating water waves. *Applied Ocean Research*, 17(6), pp. 379-389.
- Falnes, J. (1999) Wave energy conversion through relative motion between two single mode oscillating bodies. *Journal of Offshore Mechanics and Arctic Engineering*, 121(1), pp. 32-38.
- Falnes, J. (2002) *Ocean waves and oscillating systems: linear interactions including wave energy extraction*. Cambridge: Cambridge University Press.
- Festus, D. and Yerima, J.B., 2025. Assessment of Wave Energy Resources at Brass Coast in Rivers State, Nigeria.
- Giorgi, G. and Ringwood, J.V. (2016) Implementation of latching control in a numerical wave tank with regular waves. *Journal of Ocean Engineering and Marine Energy*, 2(2), pp. 211-226.
- Giorgi, G. and Ringwood, J.V. (2017) Nonlinear Froude Krylov and viscous drag representations for wave energy converters in the computation/fidelity continuum. *Ocean Engineering*, 141, pp. 164-175.
- Guo, B., Patton, R., Jin, S., Gilbert, J. and Parsons, D. (2017) Non-linear modelling and verification of a heaving point absorber for wave energy conversion. *IEEE Transactions on Sustainable Energy*, 9(1), pp. 453-461.
- Guo, Q. and Xu, Z. (2011) Simulation of deep water waves based on JONSWAP spectrum and realization by MATLAB. In: *Proceedings of the 2011 19th International Conference on Geoinformatics*, Shanghai, China, 24-26 June 2011, pp. 1-4.
- Guy, H., Basil, B., Mathias, A., Bernard, N. and Viano, I. (2018) Wave energy resources assessment offshore Benin from ERA re-analysis: Gulf of Guinea. *Physical Science Internal Journal*, 19(4), pp. 1-11.
- Hadano, K., Lee, K.Y. and Moon, B.Y. (2016) A study on dynamic motion and wave power in multi connected wave energy converter. *Ships and Offshore Structures*, 11(6), pp. 679-687.

- Iglesias, G. and Carballo, R. (2010) Offshore and inshore wave energy assessment: Asturias (N Spain). *Energy*, 35(5), pp. 1964-1972.
- Iglesias, G. and Carballo, R. (2011) Choosing the site for the first wave farm in a region: a case study in the Galician Southwest (Spain). *Energy*, 36(9), pp. 5525-5531.
- Kara, F. (2010) Time domain prediction of power absorption from ocean waves with latching control. *Renewable Energy*, 35(2), pp. 423-434.
- Leavitt, C. (1885) Mechanism for utilizing wave power. U.S. Patent US321229A, 30 June 1885.
- Li, Y. and Yu, Y.-H. (2012) A synthesis of numerical methods for modeling wave energy converter point absorbers. *Renewable and Sustainable Energy Reviews*, 16(6), pp. 4352-4364.
- Liang, C. and Zuo, L. (2017) On the dynamics and design of a two body wave energy converter. *Renewable Energy*, 101, pp. 265-274.
- Liang, C., Ai, J. and Zuo, L. (2017) Design, fabrication, simulation and testing of an ocean wave energy converter with mechanical motion rectifier. *Ocean Engineering*, 136, pp. 190-200.
- Nwaokocha, C.N. and Layeni, A.T. (2013) Ocean wave energy – an option for Nigerian power situation. *Scientific Research and Essays*, 8(25), pp. 1547-1552.
- Park, J.S., Gu, B.-G., Kim, J.R., Cho, I.H., Jeong, I. and Lee, J. (2017) Active phase control for maximum power point tracking of a linear wave generator. *IEEE Transactions on Power Electronics*, 32(10), pp. 7651-7662.
- Pastor, J. and Liu, Y. (2014) Frequency and time domain modeling and power output for a heaving point absorber wave energy converter. *International Journal of Energy and Environmental Engineering*, 5(2-3), pp. 1-12.
- Polinder, H., Mecrow, B.C., Jack, A.G., Dickinson, P.G. and Mueller, M.A. (2005) Conventional and TFPM linear generators for direct-drive wave energy conversion. *IEEE Transactions on Energy Conversion*, 20(2), pp. 260-267.
- Rhinefrank, K., Schacher, A., Prudell, J., Brekken, T.K.A., Stillinger, C., Yen, J.Z., Ernst, S.G., von Jouanne, A., Amon, E., Paasch, R., et al. (2012) Comparison of direct drive power takeoff systems for ocean wave energy applications. *IEEE Journal of Oceanic Engineering*, 37(1), pp. 35-44.
- Richter, M., Magana, M.E., Sawodny, O. and Brekken, T.K.A. (2013) Nonlinear model predictive control of a point absorber wave energy converter. *IEEE Transactions on Sustainable Energy*, 4(1), pp. 118-126.

- Ruehl, K. and Bull, D. (2012) Wave energy development roadmap: design to commercialization. In: *Proceedings of the 2012 OCEANS*, Hampton Roads, VA, USA, 14-19 October 2012.
- Ruehl, K., Brekken, T.K.A., Bosma, B. and Paasch, R. (2010) Large scale ocean wave energy plant modeling. In: *Proceedings of the 2010 IEEE Conference on Innovative Technologies for an Efficient and Reliable Electricity Supply*, Waltham, MA, USA, 27-29 September 2010, pp. 379-386.
- Sang, Y., Karayaka, H., Yan, Y., Zhang, J.Z., Muljadi, E. and Yu, Y.-H. (2015) Energy extraction from a slider-crank wave energy converter under irregular wave conditions. In: *Proceedings of the OCEANS 2015 MTS*, Washington, DC, USA, 19-22 October 2015, pp. 1-7.
- Sang, Y.R., Karayaka, H.B., Yan, Y.J. and Zhang, J.Z. (2014) Resonance control strategy for a slider crank WEC power take-off system. In: *Proceedings of the 2014 OCEANS*, St. John's, NL, Canada, 14-19 September 2014.
- Shi, H.D. and Huang, S.T. (2016) Hydrodynamic analysis of multi-freedom floater wave energy converter. In: *Proceedings of the OCEANS 2016*, Shanghai, China, 10-13 April 2016.
- Sierra, J.P., White, A., Mösso, C. and Mestres, M. (2017) Assessment of the intra annual and inter-annual variability of the wave energy resource in the Bay of Biscay (France). *Energy*, 141, pp. 853-868.
- Ulvgård, L., Sjökvist, L., Göteman, M. and Leijon, M. (2016) Line force and damping at full and partial stator overlap in a linear generator for wave power. *Journal of Marine Science and Engineering*, 4(4), p. 81.
- Viet, N.V., Xie, X.D., Liew, K.M., Banthia, N. and Wang, Q. (2016) Energy harvesting from ocean waves by a floating energy harvester. *Energy*, 112, pp. 1219-1226.
- Wang, X. (2016) Analysis of electromagnetic vibration energy harvesters with different interface circuits. In: *Frequency Analysis of Vibration Energy Harvesting Systems*. Amsterdam: Elsevier Inc., pp. 69-106.
- Wilsnon, M., Antonio, S., Antonio, F. and Joaqui, F. (2017) Statistical analysis of wave energy resources available for conversion at natural caves of Cape-Verde Islands. *International Journal of Renewable Energy Sources*, 2(3).
- Xiao, H., Wang, X. and John, S. (2016) A multi degree of freedom piezoelectric vibration energy harvester with piezoelectric elements inserted between two nearby oscillators. *Mechanical Systems and Signal Processing*, 68-69, pp. 138-154.
- Yavuz, H., McCabe, A., Aggidis, G. and Widden, M.B. (2006) Calculation of the performance of resonant wave energy converters in real seas. *Proceedings of the Institution of*

Mechanical Engineers, Part M: Journal of Engineering for the Maritime Environment, 220(2), pp. 117-128.

Zhao, X.-L., Ning, D.-Z., Götteman, M. and Kang, H.-G. (2017) Effect of the PTO damping force on the wave pressures on a 2D wave energy converter. *Journal of Hydrodynamics*, 29(5), pp. 863-870.

Zurkinden, A.S., Ferri, F., Beatty, S., Kofoed, J.P. and Kramer, M.M. (2014) Non-linear numerical modeling and experimental testing of a point absorber wave energy converter. *Ocean Engineering*, 78, pp. 11-21.