

**DESIGN OF A 3.5KVA STANDALONE HYBRID INVERTER POWER
SYSTEM**

BY

EDIALE JUSTINE EFUA	ENG1704179
GBIAYE MARIETTE AJUCHI-EJOVWOKE	ENG1704190
IDEMUDIA UWA OSAZUWAMEN	ENG1709330
OHIWEREI EMMANUEL	ENG1704220
OHONBA UYIOGHOSA JADEN	ENG1704497
OLANREWAJU PELUMI	ENG1704226

**DEPARTMENT OF ELECTRICAL AND ELECTRONIC ENGINEERING
FACULTY OF ENGINEERING
UNIVERSITY OF BENIN**

SEPTEMBER 2023

**DESIGN OF A 3.5KVA STANDALONE HYBRID INVERTER POWER
SYSTEM**

BY

EDIALE JUSTINE EFUA	ENG1704179
GBIAYE MARIETTE AJUCHI EJOVWOKE	ENG1704190
IDEMUDIA UWA OSAZUWAMEN	ENG1709330
OHIWEREI EMMANUEL	ENG1704220
OHONBA UYIOGHOSA JADEN	ENG1704497
OLANREWAJU PELUMI	ENG1704226

**A PROJECT SUBMITTED TO THE DEPARTMENT OF ELECTRICAL
AND ELECTRONIC ENGINEERING, FACULTY OF ENGINEERING,
UNIVERSITY OF BENIN, BENIN CITY. IN PARTIAL FULFILMENT OF
THE REQUIREMENT FOR THE AWARD OF A BACHELOR OF
ENGINEERING (B. ENG) IN ELECTRICAL AND ELECTRONIC
ENGINEERING**

SEPTEMBER 2023

CERTIFICATION

This is to certify that this project was carried out by **EDIALE JUSTINE EFUA** with matriculation number **ENG1704497**; **GBIAYE MARIETTE AJUCHI-EJOVWOKE** with matriculation number **ENG1704190**; **IDEMUDIA UWA OSAZUWAMEN** with matriculation number **ENG1709330**; **OHIWEREI EMMANUEL** with matriculation number **ENG1704220**; **OHONBA UYIOGHOSA JADEN** with matriculation number **ENG1704497**; **OLANREWAJU PELUMI** with matriculation number **ENG1704226**.

.....

PROF. K.O. OGBEIDE

H.O.D

.....

DATE

.....

ENGR. E. EDEGBE

SUPERVISOR

.....

DATE

DEDICATION

This project is dedicated to all those who have contributed to the advancements made in solar energy generation.

ACKNOWLEDGEMENT

We extend our utmost gratitude to God Almighty for granting us the strength to initiate and successfully complete our Bachelor's degree in Electrical and Electronic Engineering at the University of Benin. With divine guidance, we overcame various obstacles to see this project to fruition.

We also wish to express our heartfelt appreciation to our project supervisor, Engr. E. Edegbe who diligently collaborated with us throughout this endeavor. His wealth of knowledge and expertise greatly contributed to our project's success. Additionally, we'd like to acknowledge Prof. K.O. Ogbeide, the Head of the Department of Electrical and Electronic Engineering, for his unwavering support in ensuring we had the necessary resources to accomplish our goals.

To all the dedicated members of the academic and non-academic staff within the Department of Electrical and Electronic Engineering, we extend our sincere thanks for playing pivotal roles in our successful journey.

A special note of gratitude is reserved for our parents and guardians, whose continuous encouragement and unwavering support sustained us throughout our university tenure. Without their presence, our achievements would not have been possible. We also want to express our gratitude to our friends who provided invaluable assistance during times of adversity. Their unwavering support carried us through the challenges we encountered.

Lastly, we extend our appreciation to all our fellow graduates from the Electrical and Electronic Engineering class of the 2021/2022 session. Our journey may have been marked by obstacles, but together, we reached the finish line. Congratulations to all of us!

ABSTRACT

The main purpose of the project was to design a 3.5KVA inverter which makes use of both solar and mains or grid supply for charging the batteries. This is to reduce the frequency of power outages experienced in our homes and businesses.

The project was carried out with the use of two 12V batteries connected in series to give a total of 24V DC which would serve as input for the inverter when on inverting mode and give an output of 220V AC for household appliances. Incorporated within the inverter was load control features, such that when the inverter stops charging and starts inverting, at a particular battery level set by the user, the heavy loads would be cut off while supply of power to the light loads continues. But when critical battery level is reached the light loads are also cut off and the inverter shuts down.

This was done using Microcontroller in controlling relays which either powers on the load or cuts off the load when the battery is low. The proposed inverter design has two outputs through which load management was achieved. One of the outputs is designated to light loads and the other to heavy loads. The Microcontroller DSPIC30F4012 controls the load stage which can be programmed through the keypad to monitor the output power to the loads in output one and two, to ensure they do not draw power beyond the limits programmed by the user. To achieve this, the Microcontroller cuts off either of the outputs which exceed the set limit. The project was successful and the test results obtained was satisfactory. The inverter's operation was consistent with the design and the desired control of power consumption and power management was achieved.

Table of Contents

CERTIFICATION	ii
DEDICATION	iii
ACKNOWLEDGEMENT	iv
ABSTRACT	v
TABLE OF CONTENTS	vi
LIST OF FIGURES	ix
LIST OF TABLES	xi
CHAPTER ONE:	1
1.1 Background to The Study	1
1.2 Statement of The Problem	1
1.3 Aim And Objectives of The Work	2
1.4 Methodology	2
1.5 Scope	3
1.6 Justification of The Study	3
CHAPTER TWO: LITERATURE REVIEW	4
2.1 Renewable Energy	4
2.1.1 Solar Energy	5
2.2 Power Inverter	9
2.2.1 Inverter Input and Output Characteristics	9
2.3 Charge Controllers	17
2.4 Batteries And Battery Bank	18
2.4.1 Types of Inverter Battery	18
2.5 Voltage Comparators	20

2.6 Transformer	21
2.6.1 Basic Operation of a Transformer	22
2.6.2 Working Principle of a Transformer	23
2.6.3 Parts of a Single-phase Transformer	23
2.6.4 EMF Equation of Transformer	24
2.6.5 Transformer Efficiency	25
2.7 Power Transistor In Inverter Design (MOSFET)	26
2.8 Relay	27
2.9 Load	27
CHAPTER THREE: DESIGN ANALYSIS	28
3.1 Design Overview	28
3.2 Design Specifications	29
3.3 Inverter Design Stage	29
3.4 Transformer Design.	29
3.4.1 Core Design	31
3.4.2 Number of Turns	32
3.4.3 Winding Coil	33
3.4.4 Mean Length per Turn, M.L.T	34
3.4.5 Total Length of Winding(T_i)	34
3.4.6 Total Mass of Copper	34
3.5 Design of Pulse Width Modulator	35
3.6 H-Bridge Driver Stage	35
3.7 MOSFET Driver Stage.	38
3.8 Low Pass LC Filter Circuit	39

3.9 Low Battery And High Battery Detector	40
3.10 Changeover Switch/Relay	41
3.10.1 Operational Principles of The Relays in This Project	42
3.11 Load Power Control Stage	44
3.12 Microcontroller	44
3.12.1 Functions of the Analog to Digital converter module as used in this project	47
3.12.2 Functions of the Data EEPROM memory as used in this project	47
3.12.3 Functions of the Motor Control Module as used in this project	47
3.13 Load Power Sensor.	49
3.14 Working Principle of Inverter	53
CHAPTER FOUR: CONSTRUCTION, TESTING, AND ANALYSIS	55
4.1 Construction	55
4.1.1 Construction of the Control Stage	56
4.1.2 Construction of the MOSFET Stage	56
4.1.3 Construction of The Transformer	57
4.2 Testing	57
4.2.1 Transformer Open Circuit Test	58
4.2.2 Transformer Short Circuit Test	59
4.2.3 Inverter Load Test	60
4.3 Analysis of Result	61
4.4 Bill of Engineering Management and Evaluation	61
CHAPTER FIVE: LIMATIONS, CONCLUSION AND RECOMMENDATION	64
5.1 Limitation of the study	64
5.2 Conclusion	64

5.3 Recommendation	65
References	66

List of Figures

Figure Caption	Page Number
2.1: A Battery	19
2.2: Battery Connection in Parallel	19
2.3: Battery Connection in series	19
2.4: Battery connection in parallel and series	20
2.5: A comparator	21
2.6: A MOSFET	26
3.1: Block diagram of an Inverter	28
3.2: Core dimension	31
3.3: Dimension of Lamination	32
3.4: MOSFET IRF3205	36
3.5: The H-Bridge Circuit Diagram	37
3.6: Pin Configuration of TLP250	39
3.7: The MO SFET driver stage using TLP250 Optocoupler	39
3.8: Low Pass LC Filter Circuit	40
3.9: Battery Voltage sensing circuit	40
3.10: Pin out and schematic symbol of a Relay	41
3.11: The Changeover circuit from mains to inverter and vice versa	43
3.12: The auxiliary load control circuit	44
3.13: Pin out of the DSPIC30f4012 microcontroller	45
3.14: Pin Out of the DSPIC30f4012 microcontroller as used in this project.	49
3.15 Current transformer Schematic	51
3.16: Complete Circuit Diagram of the Inverter	52
4.1 Schematic Diagram of the open circuit test	58
4.2. Schematic Diagram for the short circuit test	59

List of tables

Table	Page Number
4.1: Transformer Open Circuit Test	58
4.2: Transformer Short Circuit Test	59
4.3: Inverter Load Test Results	60
4.4: Bill of Engineering Measurements and Evaluation	61

CHAPTER ONE

INTRODUCTION TO THE STUDY

1.1 BACKGROUND TO THE STUDY

Energy which we use to carry out our daily activities is a function of power and time which is why the unit of measurement is watt-hours (WH). Electrical grids are created in a country as a way to provide energy to improve the quality of life for their citizens. It is made affordable so that majority of the populous can benefit from it.

In an ideal situation this would be enough to solve the need for more energy. However, in Nigeria which has an ever-growing population which currently is estimated to about 223,804,632 in 2023. This creates a huge problem because the energy generated by the electrical grid will not be sufficient for uniform and constant distribution of energy. To solve this problem, we sort for alternative sources of energy (i.e. off-grid energy).

Non-renewable sources of energy are quite expensive to sustain. To solve the problem of insufficient energy supply in our homes we have decided to use solar energy which is a renewable energy. Solar energy from the sun cannot be used directly in our homes without some form of harvesting and then conversion. The energy from the sun is captured with photovoltaic cells found in solar panels. The energy from the solar panel is in Direct Current which cannot be used directly to power our house. The hybrid inverter circuit converts the Direct Current to Alternative Current which can now be used in our homes. Another function of the hybrid function of the hybrid inverter system is to use the Direct Current from the solar panel to charge the batteries which acts as a storage bank for power during the period of no or low sunlight.

The inverter design is very beneficial because it is environmentally friendly and solves the problem of insufficient energy in how homes here in Nigeria. Although the initial installation and design of an inverter solar system unit is expensive, on the long run it is more economical and more environmentally friendly than using fuel powered generators.

1.2 STATEMENT OF THE PROBLEM

The common man in Nigeria knows about the irregularities in the availability of power supply

from the national grid of the country. Residents of Nigeria have been forced to use generators on a regular basis due to power outages. A high amount of power outage was observed to have encouraged a high incidence of generator use. Other cheaper and better alternatives have been considered. Due to the irregular power supply in Nigeria, consumers are already looking into solar energy and inverter power system as an alternative source of electricity. Due to the constant availability of sunlight to the earth, Photovoltaic systems can be greatly adopted, further more with the certainty of sunlight during the dry season, one can be sure would have power if a photovoltaic system is installed.

Inverters are also expensive to build and install. Though it is a one-time cost and have a low maintenance cost fee, incorporating the solar energy and also the inverter power system is still not enough to suffice for the electrical need of an average Nigerian home, which now leads us to energy management such as putting of some loads, so the system can be sustainable for a longer period of time.

The main reasons we embarked on this project is:

- i-**To build a sustainable power system by controlling the loads using a microcontroller, hence the system is able to serve power longer and can to an extent, be reliable.
- ii-**To solve the unavailability of power supply from the grid by using the availability of both sunlight and Inverters to generate our own power.

1.3 AIM AND OBJECTIVES OF WORK

Design and construction of a 3.5KVA hybrid inverter with load consumption monitoring using microcontrollers. The objectives are:

- i-**To employ the use of microcontrollers which commands the relay to power on the load or cut-off the loads when the battery is low.
- ii-**To install battery charging and protection circuitries into the inverter design.
- iii-**To minimize the hours/frequency of power outages that happens in homes and businesses

1.4 METHODOLOGY

The steps to carry out this project are:

- i-**Construction of the inverter with a programmed microcontroller attached to the design
- ii-**Determining components values through necessary calculations

- iii-**Inclusion of load regulator and monitor stages for load management.
- iv-**The circuit diagram is created for a 3.5KVA
- v-**Inverter with a circuit schematic for mains power presence detection and changeover.
- vi-**Research carried out on the working principles and design of an inverter.

1.5 SCOPE

The scope of this project covers sourcing for quality materials, cost estimation, designing and test running a hybrid inverter with a microcontroller for load management that is able to supply electric power up to 3.5KVA with an input of 24V dc.

1.6 JUSTIFICATION OF THE STUDY

Observing one of the major setbacks in developing country is the scarcity/lack of power supply, and reason for this project is to;

- i-**Creating a mean of power supply that cannot be interrupted, protecting critical equipment from damage due to fault current or electric supply failure.
- ii-**Improve existing design
- iii-**Economic growth is also enhanced as its directly having hinderance from power supply.
- iv-**Make an alternative that can supply electrical power for easy running of companies, business to enable them meet up with the task of our day to day activities and providing comfort and entertainment in residential homes.

CHAPTER TWO

LITERATURE REVIEW

2.1 RENEWABLE ENERGY

Natural resources which includes all the natural occurring resources such as wind, sun, water, biomass and natural gases, just to name a few, have been channeled and utilized in recent years towards the generation of energy. The process which achieves this is what we refer to as renewable energy generation. Energy in recent times has become so essential and is basically a most have in any properly functioning society and because of this, over the years the adoption of renewable sources of energy has become unavoidable. The use of renewable sources of energy ensures continuous availability especially in the cases of hydropower generation and solar power generation, but despite all this nature could still be quite unpredictable and because of this energy storage devices for power are essential and they end up acting as an emergency backup supply. (Tovar-Facio Javier, 2022)

Although the initial cost for implementing renewable energy generation systems is always high, on the long run it's more economical and sustainable than fossil fuels. This is why most nations including Nigeria has adopted renewable sources of energy. Nigeria as a country generates most of its power from thermal plant and hydroelectric dams and although Nigeria hasn't even begun to generate the required amount of energy its citizens need it's comforting to see that they are taking a step in the right direction. (Bamisele, 2017)

Renewable energy refers to energy that can be gotten from natural resources that are naturally replenished on human timescales. These resources are inherently abundant and have the potential to provide power without the harmful environmental consequences associated with fossil fuels. (Muddassar, Sobia, & Muhammad, 2022)

It has gained prominence due to their potential to address two crucial global challenges: environmental degradation and energy security. By harnessing the power of nature, we can reduce carbon emissions, combat climate change, and mitigate the adverse effects of traditional energy sources. Moreover, renewable energy offers a pathway to greater energy resilience and independence, lessening the vulnerabilities tied to fossil fuel dependency. (Razi & Ali, 2018)

Renewable energy in recent times in Nigeria is gaining traction because the nation now seeks to diversify its energy sources and reduce its reliance on fossil fuels. Nigeria faces significant

energy challenges due to a growing population and increasing energy demand. Traditional energy sources, like fossil fuels, are often unreliable and contribute to serious environmental pollution. Nigeria is blessed with abundant renewable energy resources, which includes sunlight, wind, water and biomass. These natural resources provide opportunities for sustainable energy generation across the country, Nigeria is being located in the tropical region of West Africa which is characterized by warm temperatures throughout the year and distinct wet and dry seasons. Nigeria has abundant sunlight, making solar energy a promising renewable source of energy. Solar power projects, both grid-connected and off-grid, have been implemented to provide electricity rural areas and solve the problem of energy deficit. The northern regions in Nigeria have favorable wind conditions, which make wind energy a viable option. Wind farms are being developed to harness this potential. Nigeria has large rivers such as the Niger and Benue. Existing hydroelectric plants are being expanded, and new projects are in the planning stages. Nigeria's large agricultural sector makes biomass a viable energy source. (Elehinafe, Okedere, Mamudu, & Emetere, 2021)

As we navigate the challenges of a changing climate and strive for a cleaner energy future, renewable energy stands as a beacon of possibility. Its capacity to generate power while safeguarding our environment underscores its transformative potential. By embracing renewable energy, we take a decisive step towards a more sustainable, resilient, and equitable energy landscape for generations to come. (Brent, 2021)

2.1.1 SOLAR ENERGY

The energy from the sun is in the form of electromagnetic radiation, including visible light, ultraviolet radiation, and infrared radiation. The sun's energy output is estimated to be around 3.8×10^{26} watts, or 380,000,000,000,000,000,000,000 watts. This measurement is referred to as the solar luminosity. It represents the total power radiated by the sun into space. To put this staggering number into perspective, consider that earth's total energy consumption in a year is a fraction of the sun's energy output in a single second. The sun's energy production is fueled by nuclear fusion reactions in its core, where hydrogen nuclei combine to form helium, releasing a tremendous amount of energy in the process. (Bauer, 2015)

While humanity currently relies on only a fraction of the sun's energy through solar power technologies, the potential to harness more of this energy for our needs is significant. Even a

small fraction of the sun's energy could meet global energy demands many times over. (Megantoro, Syahbani, Sukmawan, Perkasa, & Vigneshwaran, 2022)

Solar energy conversion involves the process of transforming sunlight into usable forms of energy, such as electricity or heat. This conversion is crucial for harnessing the abundant and renewable energy emitted by the sun. There are primarily two main methods of solar energy conversion: (Adelakun & Olanipekun, 2019)

1. Photovoltaic (PV) Conversion:

Photovoltaic (PV) conversion is a process by which sunlight is directly converted into electricity using photovoltaic cells, commonly known as solar cells. Photovoltaic conversion is a clean and reliable method of generating electricity. It requires no moving parts, produces no emissions, and can be deployed in various scales, from small rooftop installations to large solar farms. Advances in photovoltaic technology have led to improved efficiency, reduced costs, and increased accessibility to solar power. As research and development continue, the potential of photovoltaic conversion to meet a significant portion of global energy demand grows, contributing to a sustainable and low-carbon energy future. (Johansson & Andruszkiewicz, 2022)

Photovoltaic cells, commonly known as solar cells, directly convert sunlight into electricity. These cells are typically made from semiconductor materials like silicon. When sunlight strikes the surface of the solar cell, it excites electrons within the material, generating an electric current. This direct conversion of light into electricity is the hallmark of photovoltaic technology. The key principles behind photovoltaic conversion include the photovoltaic effect and the semiconductor properties of certain materials (Kanotra, Gupta, Massey, & Leekha, 2020)

i-The Photovoltaic Effect: When photons (particles of light) strike the surface of a semiconductor material, they transfer their energy to electrons within the material. This energy excites the electrons, causing them to break free from their normal positions in the atoms and become mobile, creating an electric current.

ii-Semiconductor Properties: Photovoltaic cells are typically made from semiconductor materials like silicon. Silicon has a specific crystalline structure that allows it to effectively capture and transport excited electrons. Silicon cells are doped (intentionally modified) to create distinct layers with different electrical properties.

iii-Generation of Electric Current: In a basic silicon photovoltaic cell, the cell consists of two layers: an N-type (negatively charged) layer and a P-type (positively charged) layer. When sunlight strikes the cell, it creates an electric field between these layers. Excited electrons from the N-type layer move toward the P-type layer, creating a flow of electric current. (Abdelhady, Abd-Elhady, & Fouad, 2017)

iv-Collection of Electricity: The flow of electrons creates a direct current (DC) that can be collected and used for various applications. Multiple photovoltaic cells are connected in series or parallel configurations to form solar modules or panels. These panels are then connected to form solar arrays that generate larger amounts of electricity. (Tayagaki, Shimura, Sasaki, & Yoshita, 2021)

2. Solar Thermal Conversion:

Solar thermal systems capture sunlight's heat to create hot fluids or air, which can then be used for various purposes, including space heating, water heating, and industrial processes. There are two main types of solar thermal systems (Ran, Li, Xu, & Wang, 2020):

i-Solar Water Heating: In a solar water heater, sunlight heats a fluid (usually water or a water-antifreeze mixture) within collectors. The heated fluid is then used to heat water for residential, commercial, or industrial use.

ii- Concentrated Solar Power (CSP): CSP systems use mirrors or lenses to focus sunlight onto a small area, generating high temperatures. This heat is then used to produce steam, which drives turbines connected to generators to produce electricity.

Both photovoltaic and solar thermal technologies play critical roles in the broader effort to transition from fossil fuels to renewable energy sources. Photovoltaics excel at producing electricity in a distributed manner, while solar thermal systems are particularly efficient for generating heat in larger-scale applications (Sharma, et al., 2022)

COMPONENTS INVOLVED IN DESIGNING AN INVERTER

i-Charge Controller: This component manages the charging process of the battery, ensuring that the battery receives the correct voltage and current for optimal charging and preventing overcharging. (Zainurin, Anas, & Singh, 2021)

ii-MOSFETs (Metal-Oxide-Semiconductor Field-Effect Transistors): These are electronic switches used to control the flow of current between the DC input and the transformer in an inverter. They help in converting the DC input into AC output.

iii-Transformer: A transformer converts the low voltage and high current DC input into the desired AC output voltage and current. It helps in stepping up or stepping down the voltage levels.

iv- Battery: The battery stores the DC energy needed to power the inverter and supply power when the main power source is unavailable. It acts as an energy reservoir.

v-Relays: Relays are switches controlled by an electrical signal. They help isolate high-voltage circuits (like the transformer) from the low-voltage control circuits, ensuring safety and control.

vi-Voltage Regulator: This component ensures a stable and consistent output voltage, even as the input voltage or load changes. It helps maintain the quality of the AC output.

vii-Light Emitting Diodes (LEDs): LEDs are used as indicators to show the status of the inverter, such as power on, fault conditions, or battery charging status.

viii-Resistors: Resistors are used to control current and voltage levels in various parts of the circuit. They help in setting reference values and limiting current flow.

ix-Diodes: Diodes allow current to flow in only one direction. They can be used to control the flow of current and prevent reverse current flow, which is important in certain parts of the circuit.

x-Capacitors: Capacitors store and release energy, helping to smooth out voltage fluctuations and improve the stability of the output waveform.

xi-Transistors: Transistors are used for amplification and switching purposes. They play a role in controlling the current flow through MOSFETs and other components.

xii-Cables: Cables are essential for connecting various components within the inverter system. Proper cable sizing and insulation are crucial for safety and efficient power transmission.

These components work together to create an inverter system that can convert DC power from a battery into AC power suitable for powering various devices and appliances. Each component has a specific function that contributes to the overall functionality and performance of the inverter. (Hoyos Velasco, Hoyos Velasco, & Candelo-Becerra, 2019)

2.2 POWER INVERTER

A power inverter is an electronic apparatus or circuitry that transforms direct current (DC) into alternating current (AC). The specific device used determines the resultant AC frequency. The configuration of the particular apparatus or circuitry dictates factors such as input voltage, output voltage, frequency, and overall power capacity. It's important to note that the inverter itself doesn't generate electricity; rather, it facilitates the delivery of power from the DC source. (Shahparasti, Mohamadian, Teimourzadeh Baboli, & Yazdian, 2015)

In cases involving rotary systems, a power inverter might combine mechanical and electronic components, or it could be entirely electronic in nature. Alternatively, static inverters avoid the use of moving parts during the conversion process.

Power inverters are commonly employed in applications with elevated current and voltage levels in the realm of electrical power. Certainly, here's a concise and comprehensive explanation of inverter input and output characteristics:

2.2.1 INVERTER INPUT AND OUTPUT CHARACTERISTICS

1. INPUT VOLTAGE

The input voltage of an inverter refers to the level of DC voltage that the inverter requires to function properly. This voltage is supplied by the power source connected to the inverter, such as a battery, solar panel array, or other energy storage systems. The input voltage is a critical parameter, as it directly affects the inverter's performance, efficiency, and compatibility with the electrical system it is meant to power for example: (Choi, Yoon, & Kim, 2022):

i-Consumer and Commercial Inverters: In the realm of smaller consumer and commercial inverters, an input voltage of 12 volts DC is commonly utilized. These types of inverters, frequently employed for devices like laptops and small electronics, often draw power from sources such as 12-volt lead-acid rechargeable batteries or the electrical sockets in automobiles.

ii-Household Energy Systems: For residential energy setups, there are three predominant input voltage standards: 24, 36, and 48 volts DC. These voltage levels are well-suited to meet the energy requirements of households while ensuring compatibility and safety.

iii-Photovoltaic Solar Panels: When solar panels serve as the power source, the inverter's input voltage typically spans from 200 to 400 volts DC. This range is strategically selected to optimize the conversion of solar energy into usable electrical power.

iv-Electric Car Battery Packs and Vehicle-to-Grid Systems: In the context of vehicle-to-grid systems where electric car battery packs contribute power, the inverter's input voltage falls within the range of 300 to 450 volts DC. This voltage range aligns with the capabilities of electric vehicle battery packs, enabling efficient power transfer between the grid and the vehicles.

v-High-Voltage Direct Current Power Transmission: In the realm of high-voltage direct current power transmission systems, the inverter's input voltage can escalate to hundreds of thousands of volts. This situation arises when the inverter is an integral component of a high-voltage DC transmission network, which is employed for the efficient long-distance distribution of electricity.

In essence, the input voltage of an inverter is a dynamic parameter that caters to a variety of applications and scenarios. By tailoring the input voltage to suit the inverter's design and intended purpose, these devices can effectively facilitate the conversion of DC power to AC power, enabling the operation of electrical equipment across a wide spectrum of needs. (Puukko & Suntio, 2012)

2. OUTPUT WAVEFORM

The output waveform of an inverter can vary based on its circuit design, and it typically falls into several categories: square wave, modified sine wave, pulsed sine wave, pulse width modulated (PWM) wave, or sine wave. (Catur Rakhmad Handoko, 2019)

Square waves or quasi-square waves are common output waveforms generated by many types of inverters. These waveforms have abrupt transitions between high and low voltage levels, resulting in a more simplistic and angular waveform compared to other types.

Modified sine waves are an approximation of a true sine wave. They include a series of stepped voltage levels that aim to replicate the basic characteristics of a sine wave. While they may not be as smooth as a sine wave, they are often compatible with a wide range of devices.

Pulsed sine waves are intermittent and consist of bursts of sine wave segments. These waveforms are less common and are used in specific applications.

Pulse width modulated (PWM) waveforms involve controlling the width of pulses in order to simulate a smoother waveform. These waveforms can approach the quality of a sine wave and are used to reduce harmonic distortion. (Ruiz-Gonzalez, Meco-Gutierrez, Heredia-Larrubia, Perez-Hidalgo, & Vargas-Merino, 2019)

Sine waves are the most ideal and natural waveform, closely resembling the AC power supply from utility companies. They are smooth and continuous, making them suitable for a wide range of devices.

The purity of a sine wave is often assessed using a parameter called total harmonic distortion (THD). THD measures the presence of harmonics or additional frequency components in a waveform. For example, a sine wave with a 48 percent THD is somewhat comparable to a square wave with a 50% duty cycle, meaning the voltage spends half the time at the high level.

In practical terms, commercial energy distribution networks and power grid connections have standards for THD. For customer connections, the requirement may be less than 3% THD in the waveform. IEEE Standard 519 specifies that equipment connecting to a power grid should maintain THD of less than 5%, ensuring a reasonable level of waveform quality and stability in the distributed power.

To convert a lower DC supply voltage into a form suitable for home use, there are two primary methods. These methods enable the transformation of DC power into AC power that can be used for plugging into standard household outlets.

i-Switching Boost Converter followed by AC Conversion:

The first method involves using a switching boost converter. This converter takes the lower-voltage DC supply and increases its voltage to a higher level. The boosted DC voltage is then fed into an inverter to convert it into AC power. This AC power is then suitable for home use, as it can be plugged into regular household outlets. The switching boost converter plays a crucial role in stepping up the voltage to a level that is compatible with the inverter's input requirements.

ii-Line-Frequency Transformer with DC-to-AC Conversion:

The second method employs a line-frequency transformer in conjunction with DC-to-AC conversion. In this approach, the lower-voltage DC power is first converted into AC power at the battery level using an inverter. This AC power is then fed into a line-frequency transformer. The transformer steps up the voltage to the desired level for home use. The AC output of the transformer can then be plugged into standard household outlets.

3. SQUARE WAVE

Indeed, the square wave is one of the most fundamental waveforms that an inverter can generate. It's characterized by its abrupt transitions between high and low voltage levels, creating a pattern that resembles a series of square shapes, hence the name "square wave." While square wave output is suitable for certain applications, it may not be appropriate for others due to its specific characteristics.

Advantages of Square Wave Output:

- i-Simplicity:** Generating a square wave is relatively straightforward in terms of circuit design, making it suitable for simpler inverter setups.
- ii-Low-Sensitivity Applications:** Square wave output works well in applications that don't require precise AC power, such as lighting and resistive heating. These devices are less sensitive to variations in waveform quality.

Disadvantages of Square Wave Output:

- i-Incompatibility with Delicate Electronics:** Square wave output can be problematic for delicate electronics and devices that expect a smooth sinusoidal waveform. Delicate components may not function properly when subjected to the rapid voltage changes of a square wave.
- ii-Harmonic Distortion:** Square waves contain a higher level of harmonic frequencies compared to more sinusoidal waveforms. These harmonics can interfere with the operation of certain devices and cause efficiency losses.
- iii- Audio Interference ("Humming"):** When used with audio equipment, square wave output can produce an audible humming or buzzing sound due to the harmonics present in the waveform.

iv-Limited Applicability: Due to its characteristics, square wave output is generally not suitable for applications that require high waveform quality, such as precision motor control, sensitive electronic devices, and certain types of audio equipment.

4. SINE WAVE

A sine wave inverter is an example of an inverter that strives to generate a sinusoidal AC waveform. This waveform is smooth and resembles the natural oscillation of AC power from utility companies. Sine wave inverters are designed to provide high-quality power output that is compatible with a wide range of electronic devices and appliances, including sensitive equipment like medical devices and audio equipment. (Ahmed & Khan, 2021)

Manufacturers often classify inverters based on the level of waveform complexity they can produce:

i-Modified Sine Wave (Three-Step) Inverters: These inverters generate a waveform that approximates a sine wave but with steps or stair-like transitions between voltage levels. While they are less refined than pure sine wave inverters, they are still suitable for many common electronic devices.

ii-Pure Sine Wave Inverters: These inverters are designed to produce a cleaner and smoother sine wave output, closely resembling utility-grade AC power. This makes them suitable for a broader range of applications, including those that are more sensitive to waveform quality.

However, it's important to note that the term "pure sine wave" can sometimes be used ambiguously. Some inverters marketed as "pure sine wave inverters" might not produce a perfectly smooth sinusoidal waveform. Instead, they might offer output that is only marginally smoother than modified sine wave inverters or even square wave inverters. This distinction is critical when dealing with devices that have stringent requirements for waveform quality.

Since many electrical devices are optimized for a sine wave AC power supply, power inverter devices aim to replicate this sine wave output when substituting standard line power. The usual electric utility provides a sine wave, sometimes with slight distortions but generally with few flaws. Sine wave inverters, which have more than three stages in their output, are more intricate and notably pricier compared to modified sine wave inverters with only three steps or square wave (one step) variants with similar power capacity. Modified sine wave power is used by

switch-mode power supply (SMPS) equipment like DVD players and personal computers. When AC motors run on non-sinusoidal power, they might generate more heat, exhibit different speed-torque patterns, or produce louder noises than they would on sinusoidal power.

5. MODIFIED SINE WAVE

The modified sine wave is generated by combining two square waves with different periods, resulting in a waveform that exhibits voltage steps of zero, peak positive, zero, peak negative, and again zero. This repeating pattern creates a voltage waveform that resembles a sinusoidal pattern more closely than a single square wave. Most affordable consumer power inverters produce modified sine waves instead of pure sine waves.

When the peak voltage values occur for half of the cycle period, the ratio of peak voltage to RMS voltage remains consistent with that of a sine wave. The DC bus voltage can be actively regulated, or the "on" and "off" periods can be adjusted to maintain a consistent RMS value output, accommodating fluctuations in the DC bus voltage. By modifying the pulse width, it's possible to change the harmonic spectra. For a three-step modified sine wave with electrical cycle pulses spaced 130 degrees apart, the total harmonic distortion (THD) is 30%, slightly exceeding that of a square wave.

Pulse-width modulation (PWM) is a technique used to alter the RMS voltage while maintaining a constant frequency. This involves adjusting the ratio of on/off time for the pulses. Gate pulses are generated and applied to each switch according to the desired pattern, resulting in the intended output. Both pulse width and modulation frequency influence the harmonic spectrum of the output. Although it's observed that a three-level waveform experiences minimal distortion when pulses extend beyond 130 degrees of the waveform, the resulting voltage still exhibits around 30% total harmonic distortion (THD), exceeding the industry standards for grid-connected power sources. While voltage harmonics typically aren't a concern when operating induction motors, harmonic distortions can still impact other aspects.

Modified sine wave power inverters can effectively power various electric devices, particularly resistive loads such as traditional incandescent light bulbs. Switch-mode power sources typically work without significant issues. However, the situation changes when a mains transformer is utilized; the extent to which it's rated can determine whether overheating issues might arise.

Nevertheless, the load might exhibit reduced efficiency and produce buzzing sounds due to the harmonics introduced by the altered sine wave. The manufacturer's specified conversion efficiency doesn't consider these harmonics, impacting the overall system efficiency. Consequently, pure sine wave inverters could offer significantly better efficiency compared to their modified sine wave counterparts.

Most AC motors can function on MSW inverters, experiencing an efficiency reduction of around 20% due to harmonic content. However, noise levels might be elevated. Implementing a series LC filter tuned to the fundamental frequency can offer assistance. The typical modified sine wave inverter topology frequently employed in consumer power inverters is as follows:

An integrated microcontroller rapidly switches Power MOSFETs on and off at approximately 50 kHz frequency. These MOSFETs draw power directly from a low-voltage DC source, like a battery. The signal is subsequently transmitted through step-up transformers to generate a higher voltage output. Typically, multiple smaller transformers are paralleled to reduce the overall inverter size. Capacitors are employed to filter the step-up transformer output, forming a high voltage DC supply. This DC supply is then pulsed by additional Power MOSFETs under the control of the microprocessor, generating the ultimate modified sine wave signal.

Enhanced inverters utilize multiple voltage levels to replicate sine waves through a sequence of incremental steps. This approach can lead to decreased voltage, current, and total harmonic distortion (THD) compared to inverters employing only alternating positive and negative pulses. Nonetheless, these advanced inverters come at a higher cost due to their increased requirement for switching components.

6. NEAR SINE WAVE PWM

An example of PWM voltage modulation is demonstrated through pulse sequences. To reduce the switching frequency, a combination of series inductors and shunt capacitors is employed for low-pass filtering. This process yields a waveform that becomes nearly sinusoidal following the filtering stage. When compared to the components necessary to enhance a modified sine wave to achieve similar harmonic purity, these filtering elements are more condensed and feasible in practice.

Utilizing a low-pass filter alongside certain PWM-based inverter configurations enables the simulation of a sine wave. These setups resemble MSN systems in terms of employing a single DC supply, yet they involve much faster switching, usually in the order of several kilohertz. This swift switching facilitates the creation of a sine wave through the gradual adjustment of pulse widths. When a microprocessor governs the switching timing, it becomes possible to precisely manage both efficiency and harmonic content.

7. OUTPUT FREQUENCY

Typically, a power inverter's standard AC output frequency matches that of a conventional power line, either at 50 or 60 hertz. The sole deviation from this norm occurs when a variable frequency is utilized in motor vehicle designs to regulate variable speed.

Furthermore, if the output of a device or circuit requires additional refinement, it might necessitate a substantially higher frequency for the transformer to achieve its optimal efficiency, especially when stepping up the voltage.

8. OUTPUT VOLTAGE

The AC output voltage of a power inverter is regularly fine-tuned to align with the grid's line voltage, usually set at 120 or 240 VAC at the distribution level. This adjustment remains consistent even when there are fluctuations in the load that the inverter is supplying power to. Consequently, the inverter can effectively operate various devices intended for standard grid electricity.

Furthermore, certain inverters allow for continuous or on-demand variations in output voltages.

9. OUTPUT POWER

The comprehensive power rating of a power inverter is generally expressed in watts or kilowatts. This measurement indirectly indicates the available power for the controlled device and the required power from the DC source. Smaller, commonly used inverter models for

commercial and consumer applications typically offer capacities ranging from 150 to 3000 watts.

In certain cases, inverter applications extend beyond pure power distribution concerns. Instead, the subsequent circuit or device may utilize the frequency and waveform characteristics for specific purposes.

2.3 CHARGE CONTROLLERS

In a typical PV system, the inverter/charger carries out two crucial functions: it converts battery DC power into home AC to power common appliances and other energy-consuming loads, and it converts household AC into DC to charge deep-cycle batteries. PV systems require a two-way energy exchange in order to successfully gather and use energy.

Additionally, hybrid inverter/chargers can charge batteries from several AC sources, such as a generator or the grid. Whether you live off the grid and have cloudy days or have utility power when the grid goes down, the inverter/charger can supply steady and prepared electricity. The energy generated by solar panels can be used to charge deep-cycle batteries with the help of a charge controller, which also prevents the current from flowing back into the PV array at night.

The two formats for charge controllers are PWM and MPPT, and they may also provide a wide range of other features. PWM is the abbreviation for pulse width modulation. MPPT stands for Maximum Power Point Tracking.

PWM charge management devices can be compared to electrical switches that are placed between batteries. The switch may be quickly turned on and off. The batteries can therefore be charged at the designated voltage. The charge current will gradually decrease with each battery charge. The main difference between MPPT devices and PWM charge control devices is their increased efficiency. MPPT charge control devices have a 30% higher charge efficiency than PWM kinds. The panel voltage and battery voltage in PWM systems must coincide. In MPPT systems, the panel series is allowed to have a higher voltage than the batteries. This leads to a system that is more flexible for system expansion. MPPT controllers are more expensive than PWM controllers. Small systems that place less emphasis on efficiency nevertheless use PWM charge controllers. Both an inverter/charger and a charge controller are required in practically all PV + storage installations. (Hassan, Bass, & Masoum, 2023)

It's possible that a charge controller is all you need in certain PV + storage scenarios. This circumstance develops when your PV array can reliably recharge your batteries throughout the year and all of your electrical loads only support DC current. (Mirzaei, Forooghi, Ghadimi, Abolmasoumi, & Riahi, 2017)

In storage/backup systems devoid of solar energy, all that is required to connect the system is an inverter/charger.

2.4 BATTERIES AND BATTERY BANK

Any inverter system's performance and lifespan are significantly impacted by the inverter battery. There are numerous brands available, but before making a final choice, it's crucial to understand all the different varieties when purchasing them for our homes or offices.

2.4.1 TYPES OF INVERTER BATTERY

Lead-acid, tubular, and maintenance-free inverter batteries are the three varieties that are now available on the market.

Lead-acid battery

The earliest kind of rechargeable battery is actually a lead-acid battery. They are made up of two electrodes that are submerged in an electrolyte solution of sulfuric acid, which produces DC current when lead and lead dioxide are present.

Tubular Battery:

These inverter batteries are a terrific investment for households and an upgraded version of lead-acid batteries. The leak-proof tower design and pencil-type armored tubular plates offer improved safety and need less maintenance even during prolonged power outages.



Figure 2.1: A Battery

Batteries connected in parallel and series to form an energy storage bank are referred to as a "battery bank" in this context. This energy bank employs a DC-AC inverter to transmit electricity to loads while storing solar energy generated by solar panels. A battery bank serves as the primary energy storage device in a solar power system.

Connecting Batteries in Parallel to Increase Capacity

- I. Wiring batteries in parallel:
- II. Increases amp-hour capacity
- III. Keeps system voltage the same

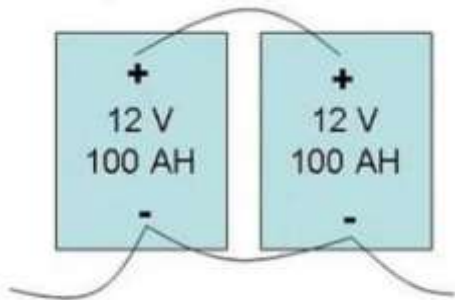

Figure 2.2: Battery Connection in Parallel

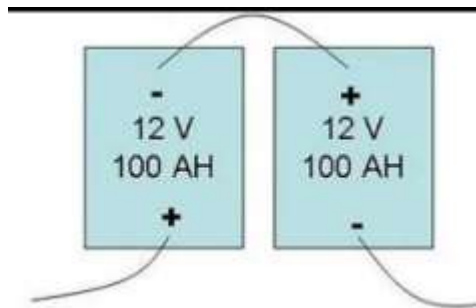

Figure 2.3: Battery Connection in series

Connecting two 12V, 100Ah batteries in parallel creates a 12V battery bank with 200 amp-hours of capacity.

Connecting Batteries in Series to Increase Voltage

- i-Wiring batteries in series:
- ii-Increases system voltage
- iii-Keeps amp-hour capacity the same

Connecting two 12V, 100Ah batteries in series creates a 24V battery bank with 100 amp-hours of capacity.

Connecting Batteries in Parallel and Series

The amp-hour capacity and battery bank voltage are both increased by combining parallel and series connections.

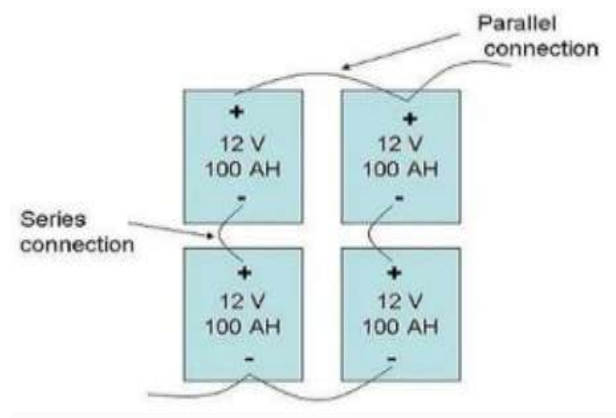

Figure 2.4: Battery connection in parallel and series

A 24V battery bank with 200 amp-hours of capacity can be made by connecting four 12V, 100Ah batteries in parallel and series.

Keep in mind that the wires that link the battery bank to the DC load center conductors are drawn from the bank's opposing diagonal ends.

2.5 VOLTAGE COMPARATORS

A voltage comparator is an electrical device that compares two voltages and produces a digital signal that indicates which is greater. It features one binary digital output terminal V_o and two analog input terminals V_+ and V_- . In a perfect world, the output would be $V_o = 1$ if $V_+ > V_-$ or $V_o = 0$ if $V_+ < V_-$.

A specialized high-gain differential amplifier makes up a comparator. They are frequently found in relaxation oscillators as well as analog-to-digital converters (ADCs), devices that measure and digitize analog signals. Comparators are used in detectors for null values, zero crossings, relaxation oscillators, level shifters, analog-to-digital converters, window values,

and absolute values.

Non-inverting comparator.

The voltage to be compared is applied to the non-inverting input of a non-inverting comparator, and the reference voltage is applied to the inverting input. Every time the voltage under comparison (V_{in}) surpasses the reference value, the output of the op-amp switches from negative saturation (V_-) to positive saturation (V_+).

Inverting comparator.

A reference voltage is applied to the non-inverting input of an inverting comparator, and a voltage to be compared is applied to the inverting input. Every time the input voltage (V_{in}) exceeds the reference value (V_{ref}), the output of the op-amp swings to negative saturation.

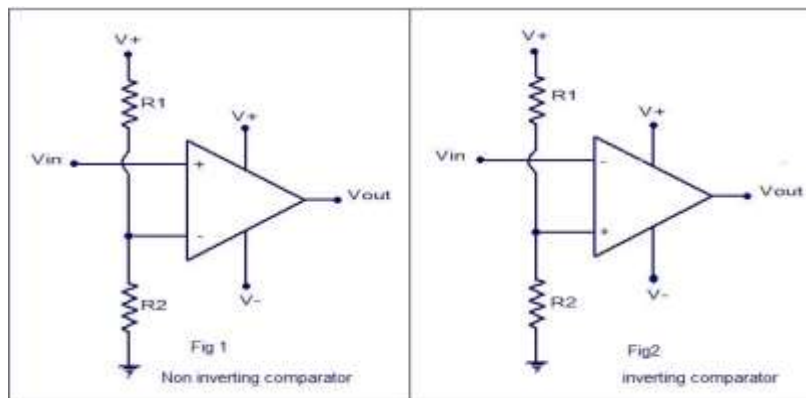

Figure 2.5: A comparator

2.6 TRANSFORMER

A transformer is utilized to either increase or decrease the voltage level of an alternating current.

2.6.1 BASIC OPERATION OF A TRANSFORMER

The basic function of a transformer is to adjust voltage either upwards or downwards. In a step-up transformer, the output voltage is increased, while in a step-down transformer, it is decreased. This adjustment of voltage also affects the current, with a step-up transformer decreasing the output current and a step-down transformer increasing the output current to maintain a balance of power.

Transformers play a crucial role in controlling voltage in the distribution and transmission of alternating current power. The concept of transformers was introduced by Michael Faraday in 1831 and has since been developed by other scientists. The main purpose of transformers is to balance the production and consumption of electricity at different voltage levels. Transformers can be categorized based on their voltage ratings, core types (such as air or iron), and winding arrangements (such as autotransformers with a single winding). (Coltman, 2002)

i-Transformers between the power generator and the power grid are known as step-up transformers, where the input voltage is lower than the secondary output voltage.

ii-Step-down transformers are used to convert a high voltage main supply to a low voltage secondary output.

Transformers can also be categorized based on the type of core they use:

i-Transformers with an air core utilize the air as a medium for the flux between the primary and secondary windings, with the windings wound on a magnetically inert strip.

ii-In iron core transformers, the windings are wound on multiple layers of iron plates to create an optimal path for flux generation.

Another way to categorize transformers is based on their winding arrangement:

Autotransformers have a laminated core and a single winding used for both the primary and secondary functions. The term "auto" in Greek means "self."

The function of this type of transformer is to convert a high voltage main supply to a low voltage secondary output.

Transformers can use different types of cores, depending on their design.

- Transformers with an air core utilize the air as a medium for the flux between the primary and secondary windings, with the windings wound on a magnetically inert strip.

- Iron core transformers have windings wound on multiple layers of iron plates, which create an efficient path for flux production.

When considering the winding arrangement, an autotransformer with a laminated core and a single winding is used. This means that the same coil serves as both the primary and secondary winding. The term "auto" comes from the Greek word meaning "self."

2.6.2 WORKING PRINCIPLE OF A TRANSFORMER

The working principle of a transformer is based on mutual induction and Faraday's law of electromagnetic induction. (Mekhitarian, 2016)

A typical transformer consists of two coils, a primary coil and a secondary coil, which are placed on the transformer core. The core is formed by laminations that are connected by strips. These coils have a high degree of mutual inductance between them. When an alternating current flows through the primary coil, it generates a changing magnetic flux.

2.6.3 PARTS OF A SINGLE-PHASE TRANSFORMER

The main components of a single-phase transformer are:

1. Core

The core of a transformer serves as a support for the winding and facilitates a low-resistance path for magnetic flux flow. The winding is wrapped around the core as shown in the figure. To minimize losses, transformers are equipped with a laminated soft iron core. The composition of the core is determined by various factors such as operational voltage, current, and power. Additionally, the diameter of the core has a direct relationship with iron losses and an inverse relationship with copper losses.

2. Windings

The wires made of copper that are wrapped around the transformer core are referred to as windings. Copper is used due to its high conductivity, which helps reduce transformer loss by minimizing resistance to current flow. Additionally, copper allows for the production of thin wires due to its high ductility. There are two main types of windings: the primary winding, which receives the supply current, and the secondary winding, from which the output is taken. To ensure insulation between the primary and secondary windings, they are coated with insulation materials.

3. Insulation Agents

Insulation agents are necessary in transformers to prevent the windings from coming into contact with each other and causing short circuits. This insulation enables the process of mutual induction and greatly influences the stability and durability of transformers.

Ideal Transformer

An ideal transformer is characterized by the absence of any losses. There is no magnetic leakage flux, no resistance in the windings, or iron loss in the core.

2.6.4 EMF EQUATION OF TRANSFORMER

The EMF equation is derived by considering the following parameters:

- N_1 : Number of turns in the primary winding
- N_2 : Number of turns in the secondary winding
- Φ : Maximum flux in Weber (Wb)
- T : Time period, representing the time taken for one cycle

The flux waveform in a transformer follows a sinusoidal pattern, reaching maximum value and decreasing to the negative maximum. Therefore, the maximum flux is attained within one-quarter of a cycle, which corresponds to the time mentioned.

$$\text{Average rate of change of flux} = \frac{\phi_m}{T/4} = 4f\phi_m \dots \dots \dots \text{Equ 2.1}$$

Where f = frequency

$$T = 1/f$$

$$\text{Induced emf per turn} = \text{rate of change of flux per turn} \dots \dots \dots \text{Equ 2.2}$$

$$\text{Form factor} = \frac{\text{rms value}}{\text{average value}} \dots \dots \dots \text{Equ 2.3}$$

$$\text{RMS Value} = 1.11(4f\phi_m) = 4.44f\phi_m \dots \dots \dots \text{Equ 2.4}$$

[form factor of sine wave is 1.11]

$$\text{RMS value of emf induced in winding} = \text{RMS value of emf per turn} \times \text{no of turns} \dots \dots \dots \text{Equ 2.5}$$

Primary Winding:

$$\text{RMS value of induced emf} = E_1 = 4.44f\phi_m \times N_1 \dots \dots \dots \text{Equ 2.6}$$

Secondary winding:

$$\text{RMS value of induced emf} = E_2 = 4.44f\phi \times N_2 \dots\dots\dots\text{Equ 2.7}$$

This is the emf equation of the transformer. For an ideal transformer with no load conditions,

$$E_1/N_1 = E_2/N_2 = 4.44f\phi_m\dots\dots\dots\text{Equ 2.8}$$

This is the emf equation of the transformer. For an ideal transformer at no load condition,

E_1 = Supply voltage on the primary winding.

E_2 = Terminal Voltage (theoretical or calculated) on the secondary winding.

2.6.5 TRANSFORMER EFFICIENCY

Transformer efficiency can be gotten by comparing output and input. The higher the efficiency of a system or machine the better it is

$$\text{Efficiency} = \frac{\text{output}}{\text{input}} \times 100\dots\dots\dots\text{Equ 2.9}$$

$$\text{Efficiency}(\eta) = \frac{P_{out}}{P_{out} + P_{Losses}} \times 100\dots\dots\dots\text{Equ 2.10}$$

$$\text{Efficiency}(\eta) = \frac{V_2 I_2 \cos\theta}{V_2 I_2 \cos\theta + P_c} \times 100\dots\dots\dots\text{Equ 2.11}$$

Where, $P_{cm} = P_{sc}$

$$P_c = P_{oc}$$

$$\eta(\text{fullload}) = \frac{V \cos\theta}{V \cos\theta + P_c + P_{cm}} \times 100\dots\dots\dots\text{Equ 2.12}$$

$$\eta(\text{loadn}) = \frac{nV \cos\theta}{nV \cos\theta + P_c + nP_{cm}} \times 100 \dots\dots\dots\text{Equ 2.13}$$

2.7 POWER TRANSISTOR IN INVERTER DESIGN (MOSFET)

What is MOSFET?

A MOSFET is a four-terminal electronic component with terminals for the source (S), gate (G), drain (D), and body (B). Typically, the source terminal and the body of the MOSFET are

connected, creating a three-terminal device like a field effect transistor. MOSFET is used in both analog and digital circuits and is typically referred to as a transistor. (Mishra & Rao, 2020)

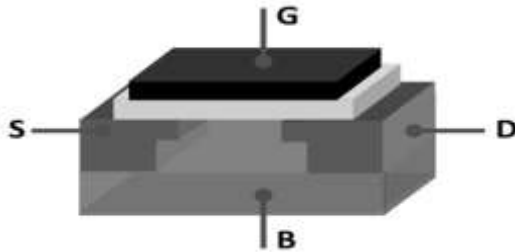

Figure 2.6: A MOSFET

Working Principle of a MOSFET

The ability to regulate the voltage and current flow between the source and drain terminals is the fundamental feature of a MOSFET device. The MOS capacitor underlies the device's operation, operating much like a switch. The main component of a MOSFET is a MOS capacitor. By applying a positive or negative gate voltage, respectively, the semiconductor surface at the bottom of the oxide layer, which is situated between the source and drain terminal, can be inverted from p-type to n-type. The holes existing beneath the oxide layer are pushed downward with the substrate when a repulsive force for the positive gate voltage is applied. (Roy, Enz, & Sallese, 2007)

the area of depletion where the bound negative charges of the acceptor atoms are found. A channel forms after electrons are contacted. Additionally, the channel's positive voltage draws electrons from the n+ source and drain regions. Now, the current flows freely between the source and drain when a voltage is applied between them, and the gate voltage regulates the channel's electron population. A hole channel will grow beneath the oxide layer if a negative voltage is applied instead of a positive one.

Application of MOSFET as a switch

Automatic brightness control in street lights is one of the best examples of this gadget being employed as a switch. These days, high-intensity discharge lamps are used in a large number of the lights that we see on roadways. However, using HID lighting requires more energy.

There must be a switch for the alternate lighting technology, which is LED, because the brightness cannot be restricted based on the necessity. The shortcomings of high-intensity lighting will be overcome by the use of LED systems. The fundamental idea behind its design was to use a microprocessor to directly control the lights on roadways.

2.8 RELAY

A relay is comprised of working contact terminals and input terminals for control signals, and can have various contact configurations including make contacts, break contacts, or both. Relays are used when multiple circuits need to be controlled by a single signal or when a circuit requires control by a separate, low-power signal. A relay consists of contact terminals that work and terminals for control signals, allowing for different contact configurations like make contacts, break contacts, or a combination of both. Relays are utilized in situations where one signal needs to control multiple circuits or when a circuit needs to be controlled by a separate, low-power signal.

2.9 LOAD

All loads can be defined as:

i-a heavy load is characterized by high energy consumption.

ii-a light load consumes minimal energy.

CHAPTER THREE

DESIGN ANALYSIS

3.1 DESIGN OVERVIEW

This chapter delves into the 3.5KVA inverter's design, with a primary focus on the design process, component selection, and parameter determination. Figure 3.1 illustrates the inverter circuit's block diagram, depicting interconnections among its various segments. (Musa & Galadanci, 2010)

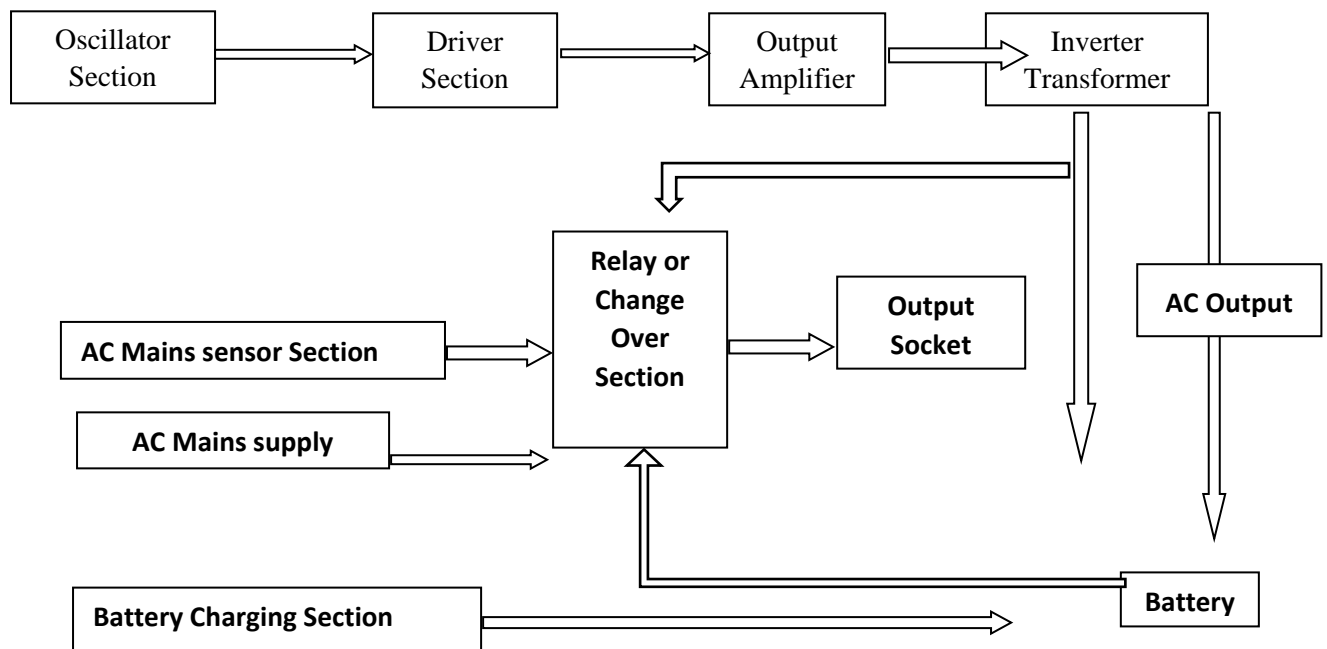

Figure 3.1: Block diagram of an Inverter

Within the inverter's control section, you'll find components such as the microcontroller, buzzer, relay, op-amp, resistors, and capacitors network. The subsequent stage, known as the H-Bridge stage, incorporates MOSFETS to convert DC voltage from the battery into AC voltage and, conversely, charge the batteries by converting AC voltage back to DC.

The transformer plays a crucial role in stepping up the AC voltage from the H-Bridge to a higher 220V level. Simultaneously, while charging the battery, it steps down incoming 220V to a lower voltage, which it then channels back to the H-Bridge.

Additionally, the changeover section, which is a part of the control section, facilitates the selection between inverter mode and mains supply by employing relays for this purpose.

3.2 DESIGN SPECIFICATIONS

Rating: 3.5KVA

Frequency: 50Hz

Number of phases: Single

Input Voltage: 24V D.C (inverter), 240V A.C (mains)

Output Voltage: 220V

Control Features: Two load control outputs

3.3 INVERTER DESIGN STAGE

This stage includes the transformer, MOSFET drivers, changeovers and feedback.

3.4 TRANSFORMER DESIGN.

The transformer ratings are:

Rating: 3.5KVA

Frequency: 50Hz

Number of phases: Single phase

Design type: Shell type

Primary Voltage: 24V

Secondary Voltage: 220V

Cooling Medium: Air forced (use of fan)

Let:

V_p : Primary Voltage

I_p : Primary Current

N_p : Number of turns in primary coil

V_s : Secondary Voltage

I_s : Secondary Current

N_s : Number of turns in secondary coil

Assuming the transformer is an ideal transformer, Output power equals input power. i.e.

$$V_p / I_p = V_s / I_s \dots\dots\dots \text{Equ 3.1}$$

$$V_s / V_p = N_s / N_p \dots\dots\dots \text{Equ 3.2}$$

Current entering the Primary side of the transformer is highest when battery Voltage is lowest, i.e 20v

$$V_{rms} = V_p / \sqrt{2} = 20 / \sqrt{2} = 14.14V$$

Therefore, transformer Input/Output Voltage is 14.14V/220V

$$\begin{aligned} \text{Secondary Current, } I_s &= \text{Secondary Power} / \text{Secondary Voltage} = 3500 / 220 \\ &= 15.91A \end{aligned}$$

Assuming transformer efficiency of 80%,

$$\text{Required Current} = 15.91 / 0.8 = 19.8875A$$

$$\begin{aligned} \text{Transformer Primary Current, } I_p &= \text{Primary Power} / \text{Power Voltage} = 3500 / 20 \\ &= 175A \end{aligned}$$

$$\text{Effective Primary Current for half cycle} = 175 / 2 = 87.5A$$

3.4.1 CORE DESIGN

$$\begin{aligned} \text{Area of the core} &= \text{Length of the window} \times \text{Breadth of the window} = L_W \times B_W \\ &= 8.176 \times 6 = 49.056 \text{cm}^2 \end{aligned}$$

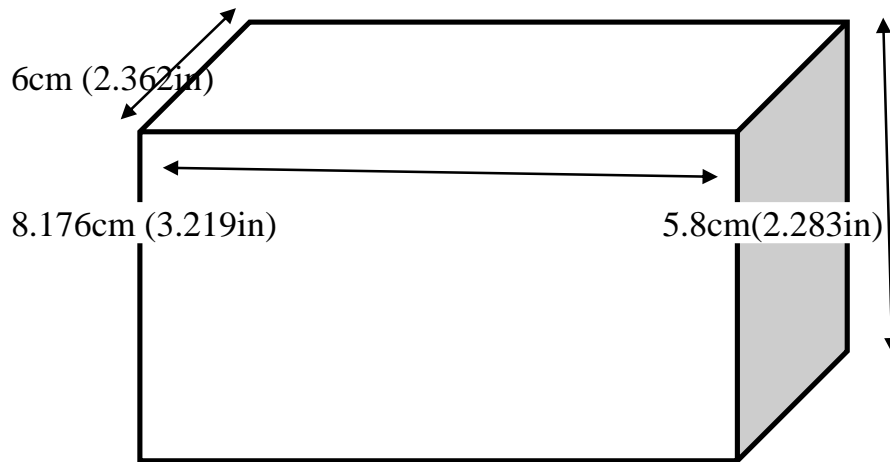

Figure 3.2: Core dimension

$$\text{Lamination pieces, } n = \frac{\text{stack height}}{\text{lamination thickness}} \dots \text{Equ 3.3}$$

$$\text{Using a thickness of } 0.5 \text{mm, } n = \frac{91}{0.5} = 182 \text{ laminations}$$

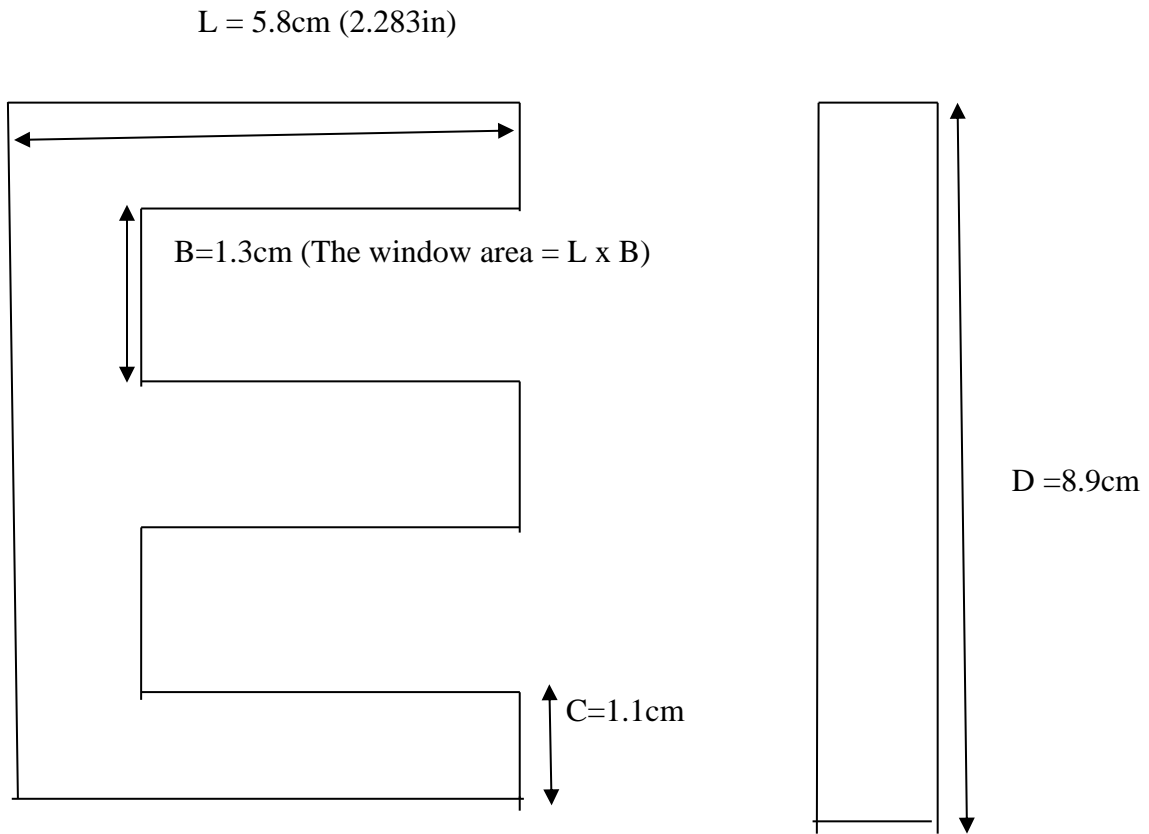

Figure 3.3: Dimension of lamination

3.4.2 NUMBER OF TURNS

From Transformer equation, $E = 4.44fN\Phi_m$ Equ 3.4

Where E = Induced Voltage

f = Frequency

N = Number of Turns

Φ = Total Flux

But $\Phi_m = B_m \times A$

Where $B_m =$ magnetic flux density

A = Core Area

Therefore, $E = 4.44fNB_mA$ Equ 3.5

Therefore, Turn per Volt, $T/V = 1/4.44fB_mA$ Equ 3.6

In designing a small transformer, B_m is taken to be between 1.2T to 1.3T.

Assuming $B_m = 1.2T$ and substituting in equ 3.6

$$= 1/4.44 \times 50 \times 1.2 \times 49.056 \times 10^{-4} = 0.765$$

For the Primary side of 14V, Number of turns, $N_p = 14 \times 0.765 = 10.71 = 11$ Turns

For the Secondary side of 220V, Number of turns, $N_s = 220 \times 0.765 = 168.3 = 169$ Turns

3.4.3 WINDING COIL

This corresponds to 5 strands of $A = I/J$ Equ 3.7

Where A = Area of Winding Coil

I = Current

J = Current density = 5 A/mm²

For Primary side, $I_p = 87.5A$

Substituting in equ 3.7,

$$A = 87.5/5 = 17.5mm^2$$

$$A = \pi d^2/4$$

$$d = \sqrt{4A/\pi} = \sqrt{4 \times 17.5/\pi} = 4.72mm$$

For Secondary side, $I_s = 19.875A$

Substituting in equ 3.7,

$$A = 19.875/5 = 3.975mm^2$$

$$d = \sqrt{4A/\pi} = \sqrt{4 \times 3.975/\pi}$$

12.5 gauge wire on the Primary side and 1 piece of 15.5 gauge wire on the Secondary side according to the Standard Wire Gauge (SWG) chart.

3.4.4 MEAN LENGTH PER TURN, M.L.T

$$\begin{aligned} \text{M.L.T} &= 2(\text{width of central limb} + \text{stack height} + \text{window width}) \dots \text{Equ 3.8} \\ &= 2(180 + 110 + 30) = 640\text{mm} \end{aligned}$$

3.4.5 TOTAL LENGTH OF WINDING (TL)

$$T_1 = \text{M.L.T} \times \text{Total number of turns} \dots \text{Equ 3.9}$$

$$\text{For Primary side, } T_1 = 640 \times 11 = 7040\text{mm} = 704\text{cm}$$

$$\text{For Secondary side, } T_2 = 640 \times 169 = 108160\text{mm} = 10816\text{cm}$$

3.4.6 TOTAL MASS OF COPPER

$$\text{Volume of Copper} = \text{Total Length of Winding} \times \text{Area of Winding} \dots \text{Equ 3.10}$$

Primary Volume:

$$\text{Area of Primary winding} = 17.5\text{mm}^2 = 0.175\text{cm}^2$$

Substituting in equ 3.10,

$$\text{Volume} = 704 \times 0.175 \times 5 = 616\text{cm}^3$$

Secondary Volume:

$$\text{Area of Secondary Winding} = 3.975\text{mm}^2 = 0.03975\text{cm}^2$$

Substituting in equ 3.10,

$$\text{Volume} = 10816 \times 0.03975 = 429.936\text{cm}^3$$

$$\text{Total volume} = \text{Primary volume} + \text{Secondary volume}$$

$$= 616 + 429.936 = 1045.936\text{cm}^3$$

$$\text{Mass} = \text{Density} \times \text{Volume}$$

$$\text{Density of Copper} = 9 \times 10^{-3} \text{ kg/cm}^3$$

$$\text{Therefore, Total Mass of Copper used} = 9 \times 10^{-3} \times 1045.936 = 9.413\text{kg} = 9.5\text{kg}$$

3.5 DESIGN OF PULSE WIDTH MODULATOR

This method is frequently utilized in power management integrated circuits, signal processing units, and communication systems, using pulse width modulation, the amount of power sent to the load can be adjusted without any energy being lost in the load driver. The Voltage-mode comparator is the most critical component of pulse-width modulator which dominates the accuracy of modulation process. The microcontroller that controls the amount of power to the loads is the microcontroller DSPIC30F4012 and when the battery is drained below a certain percentage it sends a signal to cut off power supply to all heavy loads while the power supply to the light loads continue. The Pulse Width Modulation signal was generated from four of the pins on the right side of the Microcontroller. Two Low Sides Pins and Two High Sides Pins.

3.6 H-BRIDGE DRIVER STAGE

The H-Bridge driver stage controls the power supply within the inverter system. This H-Bridge comprises 24 MOSFETs, divided into four groups, each with six MOSFETs connected in parallel. This grouping minimizes current flow through individual MOSFETs to prevent damage. These four MOSFET groups act as switches, connecting the transformer to the H-Bridge's output, converting AC power from the bridge to 220V usable by household appliances.

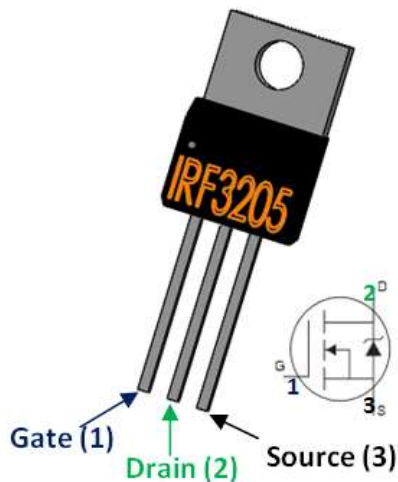

Figure 3.4: MOSFET IRF3205

The Figure 3.4 illustrates the MOSFET IRF3205 with the following specifications:

- $V_{DSS} = 55V$
- $R_{DS} = 8.0m\Omega$
- I_D at $25^\circ C = 110A$
- I_D at $100^\circ C = 80A$
- $V_{GS} = 20V$

Components Required:

Key components for building the H-Bridge circuit include resistors, capacitors, diodes, transistors (MOSFETs), optocouplers, and IC sockets.

The H-Bridge consists of four switches (MOSFETs) individually controlled to change the load's voltage polarity after each half cycle of the control signal. This process creates the necessary AC waveform from a static DC supply. It's important to note that diagonal switches must be operated simultaneously, and after one half cycle, the other diagonal pair becomes active.

The switching pattern is explained as follows:

- Two control signals govern the two diagonal pairs of MOSFETs, and they are complementary (one is active high while the other is low).

- When one signal (e.g., OUT1) is high, it turns on the low side MOSFET connected to it and the BJT transistor. This pulls the gate pin of the high side MOSFET to ground, turning it off.
- During this cycle, an electrolytic capacitor charges via the diode, reaching around 11.5 volts (supply voltage of 12V minus the diode voltage drop).
- In the next cycle, OUT1 goes low, turning off the low side MOSFET. The high side MOSFET is turned on by the voltage across the capacitor.
- The same process occurs with the other pair of high and low side MOSFETs. Since OUT1 and OUT2 signals are complementary, the H-Bridge operates effectively, turning on each diagonal pair of MOSFETs in every half cycle.

The H-Bridge converts 24V DC to 24V AC. The transformer steps up the 24V AC to 220V to power AC loads.

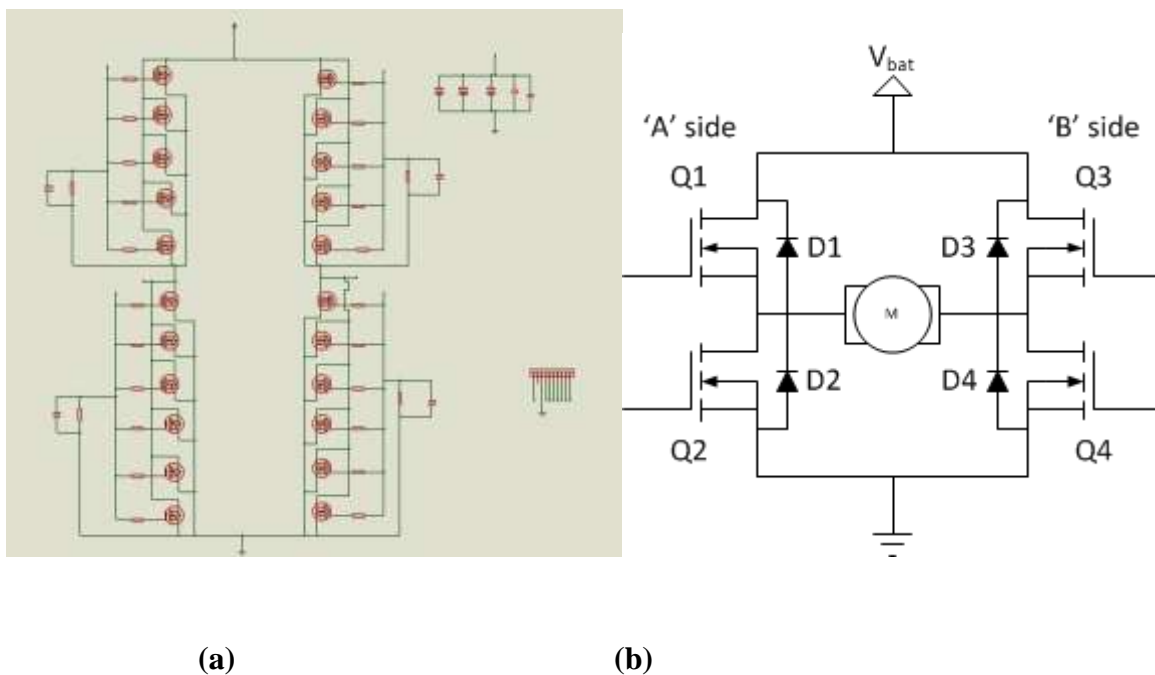

Figure 3.5: The H-Bridge Circuit Diagram

In Figure 3.5, you can see the H-Bridge Circuit Diagram, and the primary current entering the transformer is denoted as I_P , which equals $I_a + I_b$, where I_a is the current in the first half cycle from the battery, and I_b is the current in the second half cycle.

3.7 MOSFET DRIVER STAGE.

The Components used in this stage are listed below:

i-MOSFET: IRF3205(24)

ii-Resistor: 47k Ω (24), 20k Ω (24)

iii-Capacitor: 10nF(4), 15000 μ F(2), 4.7nF(1)

iv-Copper board

v-8 pin connector wire (1)

vi-TLP250(4)

The MOSFETs were driven by the TLP250. Similar to other drivers, the TLP250 has an input stage, an output stage, and a power supply connector. Because it is an optically isolated driver, the input and output are "optically separated". The input stage is an LED, and the receiving output stage has a light-sensitive reception stage that offers optical isolation. ("photodetector").

The TLP250 is an optically isolated driver, therefore it has reasonably low propagation delays even if there are optically isolated drivers that are faster than it. Typically, the propagation delay lasts 0.15 to 0.5 seconds. It's important to remember that the datasheet specifies 25kHz as the highest working frequency.

Data on TLP250

TLP250 is suitable for gate driving circuit of IGBT or power MOSFET.

i-Input threshold current: 5mA(max)

ii-Supply current: 11mA(max)

iii-Supply voltage: 10-35V

iv-Output current: \pm 1.5A (max)

v-Switching time tpLH/tpHL): 0.5 μ s(max)

vi-Isolation voltage: 2500Vrms(min)

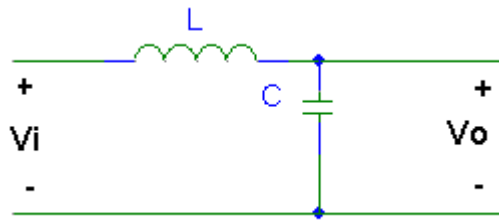

Figure 3.8: Low Pass LC Filter Circuit

3.9 LOW BATTERY AND HIGH BATTERY DETECTOR

The voltage divider network with two resistors is employed for both low battery and full battery scenarios. The microcontroller employs its integrated Analog to Digital Converter to measure battery voltage. The resistor magnitudes are specified as $R1 = 100k\Omega$ and $R2 = 12k\Omega$.

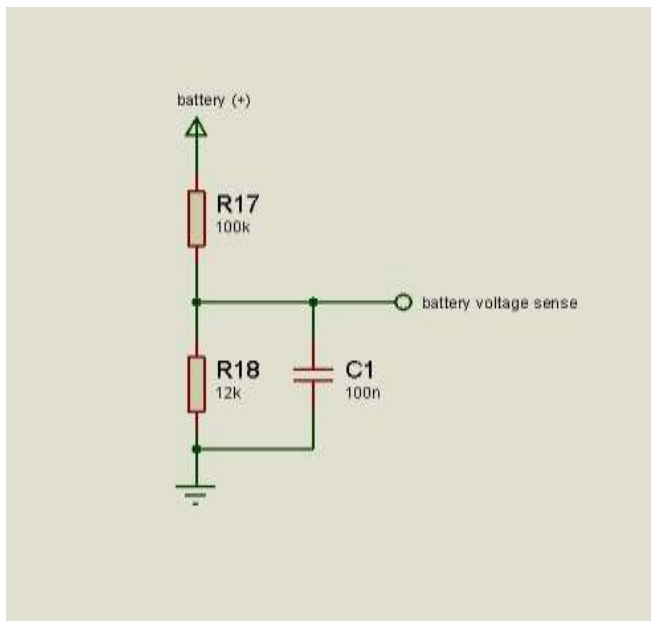

Figure 3.9: Battery Voltage sensing circuit

3.10 CHANGE OVER SWITCH/RELAY

A relay functions as a switch triggered by a separate electrical circuit, using an electromagnet to either open or close sets of contacts. It possesses the capacity to regulate output circuits, rendering it a form of electrical amplifier.

The operation of a relay can be described as follows: When a current flow through the coil, an armature linked to a moving contact is attracted to the coil. The armature's movement determines whether a connection is established or broken with a fixed contact. When the current to the coil is discontinued, an external force, usually a spring or gravity, returns the armature to its initial position. Most relays are designed for swift operation, which minimizes noise in low-voltage scenarios and reduces arcing in high-voltage or high-current situations, such as industrial motor starters.

Relays are available in versions that operate with both AC and DC power sources. In AC relays, the coil is designed to be energized by alternating current. A small copper ring can be crimped onto the end of the solenoid. This copper ring creates a slight out-of-phase current, which increases the minimum force required to pull the armature during the AC cycle.

Yet, when the coil is designed to be powered by DC, a diode is linked across the coil terminals in a manner that opposes the polarity of the power source. This setup effectively dissipates the energy from the collapsing magnetic field during deactivation, preventing voltage spikes that could potentially damage circuit elements. In certain automotive relays, these diodes might already be incorporated within the relay casing.

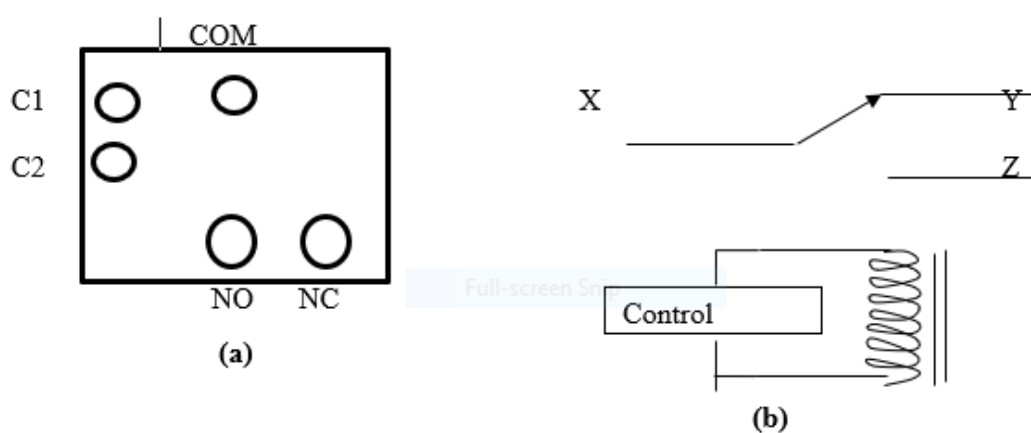

Figure 3.10: Pin out and schematic symbol of a relay

Relays often come equipped with some or all of the subsequent pin terminals:

1. Common (COM): This terminal facilitates the transfer of data among the other switching pins. Both the normally open and normally closed pins are linked to the common terminal.
2. Normally Open (NO): Prior to relay activation, this terminal maintains a direct connection with the Common. Once the relay is energized, this connection is severed from the common terminal.
3. Normally Closed (NC): This terminal is unconnected to the common terminal and is labeled as "normally closed." It remains unconnected until the relay is powered.
4. Coils: These are two pins internally linked to the relay's coils, receiving the necessary electric current to initiate the relay's switching mechanism.

Presented is an illustration depicting the internal wiring of a relay. In the absence of current passing through the electromagnet, a spring maintains the movable component called the armature on a particular side. At this juncture, Terminal X is linked to Y while remaining disconnected from Z. Upon supplying sufficient current, the armature is drawn to the opposite side. As a result, Terminal X becomes connected to Terminal Z, and the connection between Terminal Y is broken.

NO stands for the normally open terminal. This terminal remains unconnected when the relay is not activated. NC refers to the normally closed terminal, which is linked to the common terminal when not energized. The COM signifies the common terminal, serving as the point of connection to either the normally closed or the normally open terminals.

The coil terminals, labeled as C1 and C2, are where the electromagnetic coil receives the energy to activate the relay.

3.10.1 OPERATIONAL PRINCIPLES OF THE RELAYS IN THIS PROJECT

This project utilizes two relays. The primary relay serves as the main component responsible for switching between mains utility and inverter output. When a reliable utility supply is present, the system automatically transitions from inverter output to mains input. Similarly, during a mains power failure, the system switches back to the inverter output, directly

connected to the live terminal of the transformer. This switching mechanism is initiated by activating the main relay using an NPN transistor (bc547).

The auxiliary relay, which is the second relay in this setup, is responsible for managing the secondary output of the inverter. This secondary output is intended to provide power to an additional load that wasn't initially part of the main output. The activation of this relay is exclusively under the control of the microcontroller, occurring when the battery voltage falls below a predetermined level (referred to as the battery low condition, not battery shutdown). When triggered, this relay disconnects the designated loads from the inverter's output, while other loads not managed by this relay will continue to operate until the battery shutdown threshold is reached.

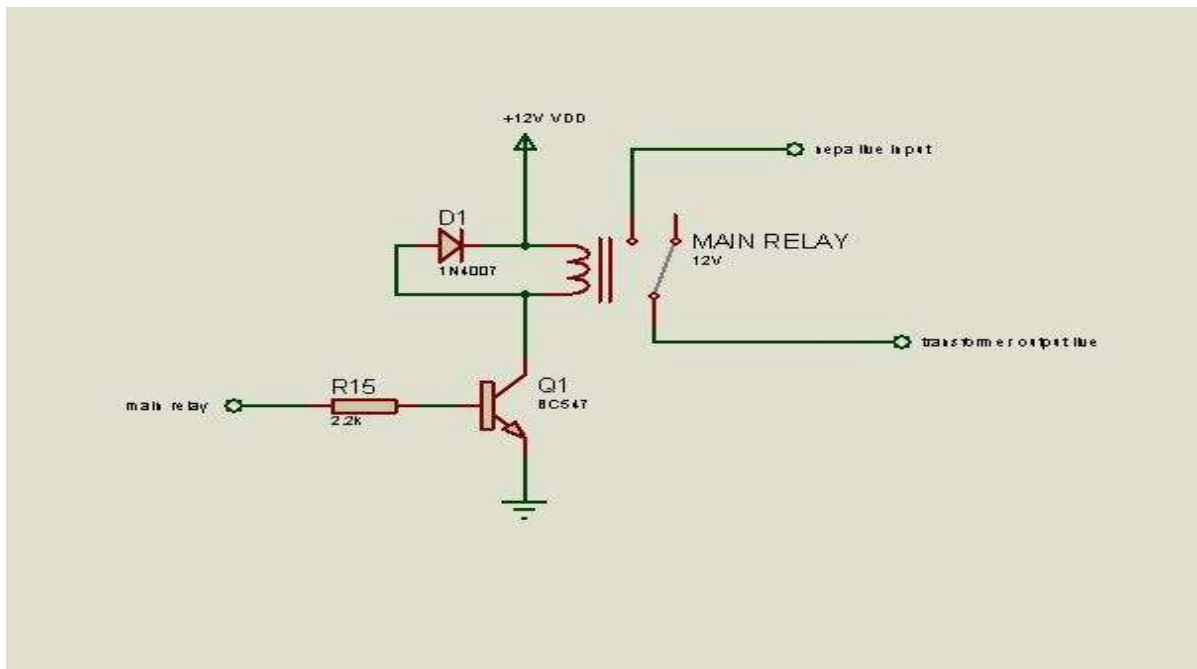

Figure 3.11: The Changeover circuit from mains to inverter and vice versa

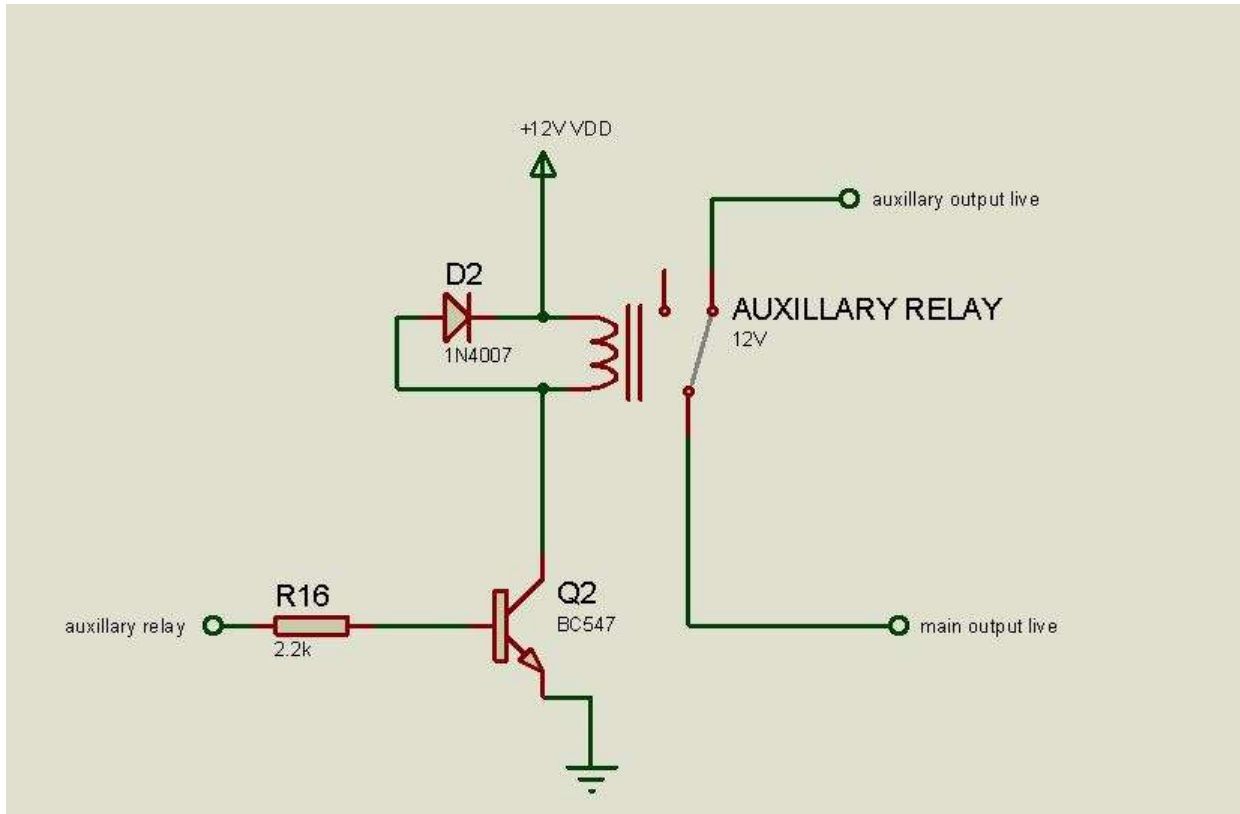

Figure 3.12: The auxiliary load control circuit

3.11 LOAD POWER CONTROL STAGE

In this phase, there are current transducers and voltage detectors that gauge the load's current and voltage. Additionally, there's a microcontroller responsible for both monitoring the power consumption of the load and executing battery monitoring tasks.

3.12 MICROCONTROLLER

The microcontroller employed in this project is the DSPIC30F4012, manufactured by Microchip Tech Inc. This 16-bit flash memory microcontroller is specifically designed to cater to both low and high-speed motor drives.

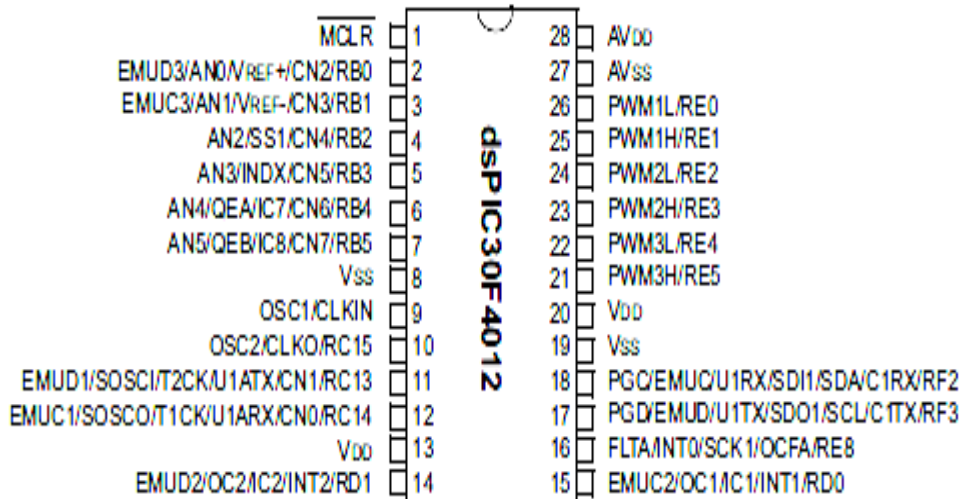

Figure 3.13: Pin out of the DSPIC30F4012 microcontroller

Key Features of the DSPIC30F4012's High-Performance Modified RISC CPU:

- i-** Employing a Modified Harvard architecture
- ii-** Incorporating an instruction set architecture optimized for C compilers
- iii-** Offering 84 foundational instructions with adaptable addressing modes
- iv-** Supporting 24-bit wide instructions and a 16-bit wide data path
- v-** Equipped with 48 Kbytes of on-chip Flash program space
- vi-** Providing 2 Kbytes of on-chip data RAM
- vii-** Featuring 1 Kbyte of non-volatile data EEPROM
- viii-** Hosting a 16 x 16-bit array of working registers
- ix-** Capable of operation at speeds up to 30 MIPS:
- x-** Accepting DC to 40 MHz external clock input
- xi-** Accommodating 4 MHz-10 MHz oscillators input with active PLL (4x, 8x, 16x)
- xii-** Offering 27 sources of interruption
- xiii-** Incorporating three external interrupt sources

xiv-Allowing for 8 user-selectable priority levels for each interrupt

xv-Supporting 4 processor exceptions and software traps.

Motor Control PWM Module Characteristics of the DSPIC30F4012:

i- 6 PWM output channels

- Choice between Complementary or Independent Output modes

- Selection of Edge and Center Aligned modes

ii-Availability of 4 duty cycle generators

iii-Presence of a dedicated time base featuring 4 modes

iv-Configurable output polarity

v- Incorporation of dead time control for Complementary mode

vi- Provision for manual output control

vii- Inclusion of a trigger for synchronized A/D conversions.

The device includes integrated Analog to Digital converters (ADC) utilized for interpreting input signals, Electronically Erasable Programmable Read Only Memory (EEPROM) employed for storing customized data and modifications to default configurations, a Motor control module responsible for steering the h-bridge MOSFETs, a DSP engine to ensure rapid processing capabilities, and a central processor, among other features.

Analog Capabilities of the DSPIC30F4012:

i- Equipped with a 10-bit Analog-to-Digital Converter (A/D) having 4 Sample-and-Hold (S/H)

Inputs:

- Achieving a conversion rate of 500 Ksps

- Supporting 9 input channels

- Allowing conversions during Sleep and Idle modes

ii-Featuring programmable Brown-out Detection and the generation of Reset signals.

3.12.1 FUNCTIONS OF THE ANALOG TO DIGITAL CONVERTER MODULE AS USED IN THIS PROJECT

The Analog to Digital converter module performs the following roles in this project:

1. Monitors the condition of the battery bank to determine its charge state and other aspects.
2. Observes the output voltage status, calculating any deviations from the preset target voltage. Rapid corrections can be implemented to maintain output stability.
3. Measures the system's temperature and decides whether to activate or deactivate the cooling fan.
4. Monitors the mains utility status to manage changeover and charging activities.
5. Provides a means for buttons to interact with the controller, facilitating calibration and parameter adjustments.

In total, this microcontroller features 7 ADC channels, of which five are utilized, while the remaining ones are configured as digital I/O pins for various functions.

3.12.2 FUNCTIONS OF THE DATA EEPROM MEMORY AS USED IN THIS PROJECT

It is utilized to store modest quantities of data and parameters, including settings like battery full, battery low, minimum and maximum acceptable mains input values, maximum load, etc.

After programming the microcontroller, parameters like those mentioned above cannot be modified without reprogramming the device. To circumvent this challenge, the EEPROM memory is employed to save and modify these parameters, eliminating the need for full erasing and reprogramming.

3.12.3 FUNCTIONS OF THE MOTOR CONTROL MODULE AS USED IN THIS PROJECT

The microcontroller played a crucial role in governing the h-bridge that housed the MOSFETs banks.

Characterized by its swift operation, low power consumption, and exceptional suitability for motor drive applications, the microcontroller was the exclusive control source for all operations within the inverter project.

Functions and Operations carried out by the microcontroller includes the following:

1. Monitoring the incoming mains utility voltage to decide on actions. If it falls within the preprogrammed range, it shifts from inverting to the mains supply. If battery charging is required, it initiates the charging process automatically.
2. Inspecting the inverter output status and implementing corrections to ensure output stays within the designated voltage level. This maintains output stability and safeguards against short circuits.
3. Assessing load status during inverting and charge current while battery charging. During inverting, the microcontroller constantly monitors load. If load surpasses the predefined maximum, the inverting mode is disabled. During charging, the microcontroller keeps charging current in check until the initial charging mode completes.
4. Monitoring the temperature of the MOSFET bank to gauge heat levels. MOSFETs function as power switches and generate heat during operation. Once temperature reaches the set point, the microcontroller activates the cooling fan using the npn transistor (bd139), which then dissipates excess heat.
5. Constantly tracking battery levels to determine when to charge, stop charging, register low battery, or identify a drained battery. This protects battery lifespan and prevents overcharging or over-discharging.

Beyond these functions, the microcontroller controls the two relays overseeing changeover and auxiliary load disconnect, manages the LCD display (using the I2C protocol) for presenting system parameters, regulates the buzzer alarm, and manages MOSFET drive functions via the embedded Motor Control PWM module.

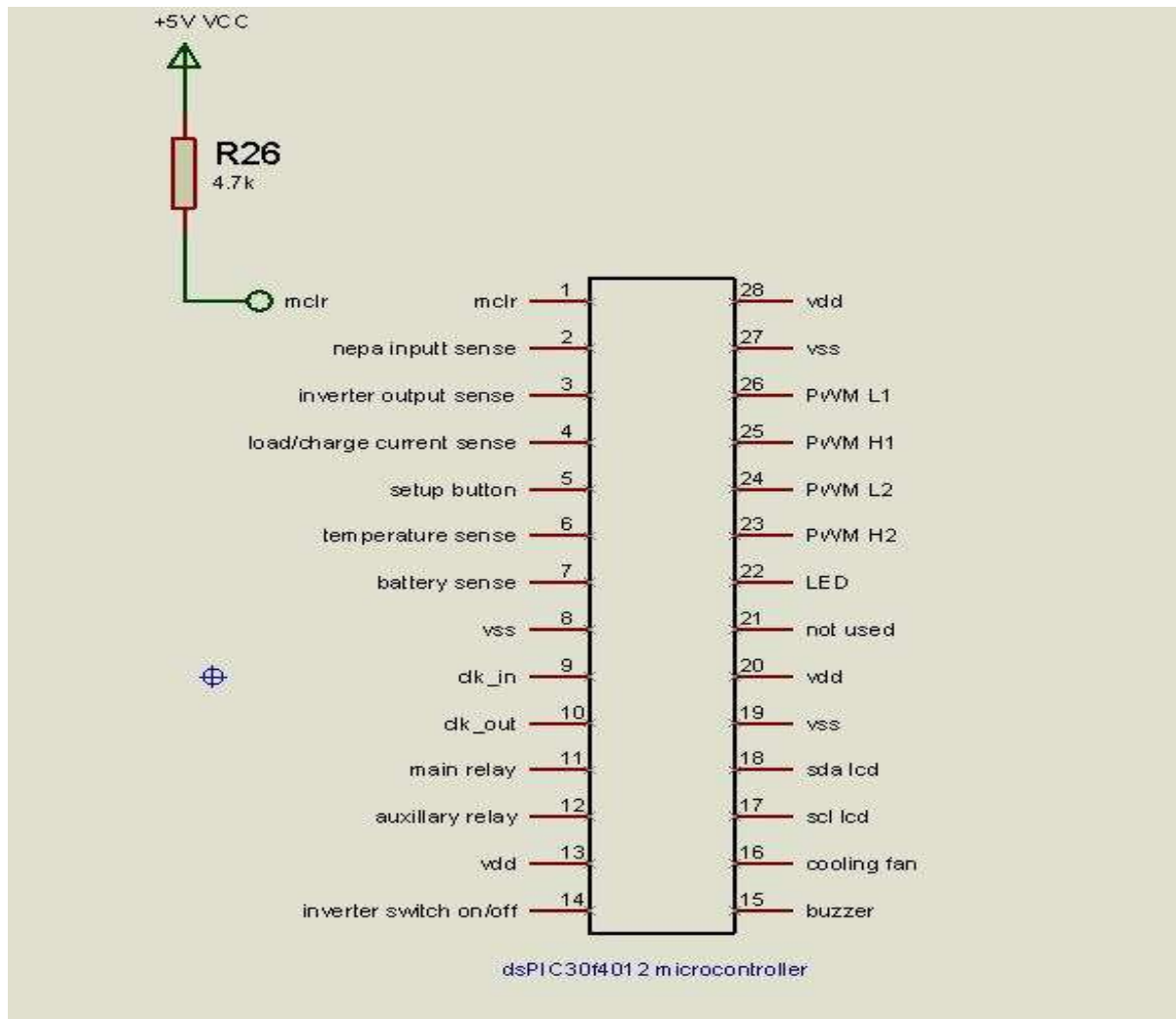

Figure 3.14: Pin Out of the DSPIC30f4012 microcontroller as used in this project.

3.13 LOAD POWER SENSOR.

A load power sensor is a crucial component in various applications, enabling the measurement and monitoring of electrical power consumption in real-time. It plays a pivotal role in energy management systems, industrial automation, and smart grids. The load power sensor calculates the power consumed by an electrical load using a combination of voltage and current measurements. This is achieved through mathematical equations, where P represents power, V denotes voltage, and I signifies current. The basic equation for calculating power is given by:

$$P=V \times I$$

In more complex scenarios, considering non-linear loads or power factor correction, the equations can involve additional factors like the power factor (PF):

$$P=V \times I \times PF$$

Load power sensors provide accurate and precise power consumption data, aiding in optimizing energy usage, identifying inefficiencies, and promoting sustainable practices. The integration of load power sensors into modern systems contributes to a more energy-efficient and environmentally conscious world.

For this project, the load Power sensor consists of voltage transducer and current transducer. The voltage transducer consists of a potential transformer (A parallel connected type of instrument transformer), while the current transducer consists of a current transformer (a type of transformer that is used to reduce or multiply an alternating current (AC)). Under load conditions, the load currents could be determined. The current transformer (CT) ratio chosen for this work is 1:1000, this is as a result of the fact that we are dealing with low current.

$$CT \text{ RATIO} = \frac{N_p}{N_s} = \frac{I_s}{I_p} = \frac{1}{1000}$$

Where N_p = primary turn.

N_s = secondary turn.

I_s = secondary current.

I_p = primary current.

$$\text{Secondary current (} I_s \text{)} = 0.001 I_p$$

For $N_p = 1$ turn

$$N_s = 1000 \text{ turns}$$

Hence,

$$I_s = 0.001 I_p = 0.001(1000) = 1 \text{ A.}$$

The output current was converted to the proportional voltage using a resistance connected to the output of the current

Transformer.

$$\text{Assuming a maximum voltage of } 10 \text{ V is to be use, the resistance would be; } R_1 = \frac{V_{out}}{I_s} = \frac{10}{1} = 10 \Omega.$$

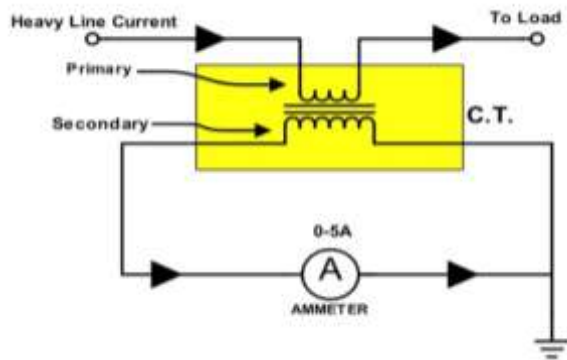

Figure 3.15: Current transformer Schematic

Since the voltage from the current Transformer is an AC, it must then be converted to a DC. This was done using a diode rectifier (bridge Rectifier).

Thus,

$$V_{rms} = 10V$$

$$\text{voltage peak } (V_p) = \sqrt{2} \times 10 = 14.14V$$

$$\text{Output Rectifier voltage} = V_p - 2V_o$$

$$V_o = \text{diode drop} = 0.6$$

$$\text{Output Rectifier voltage} = 14.14 - 2(0.6)$$

$$= 12.94V.$$

$$\text{Diode PIV rating} = V_p - V_o = 14.14 - 0.6 = 13.54V.$$

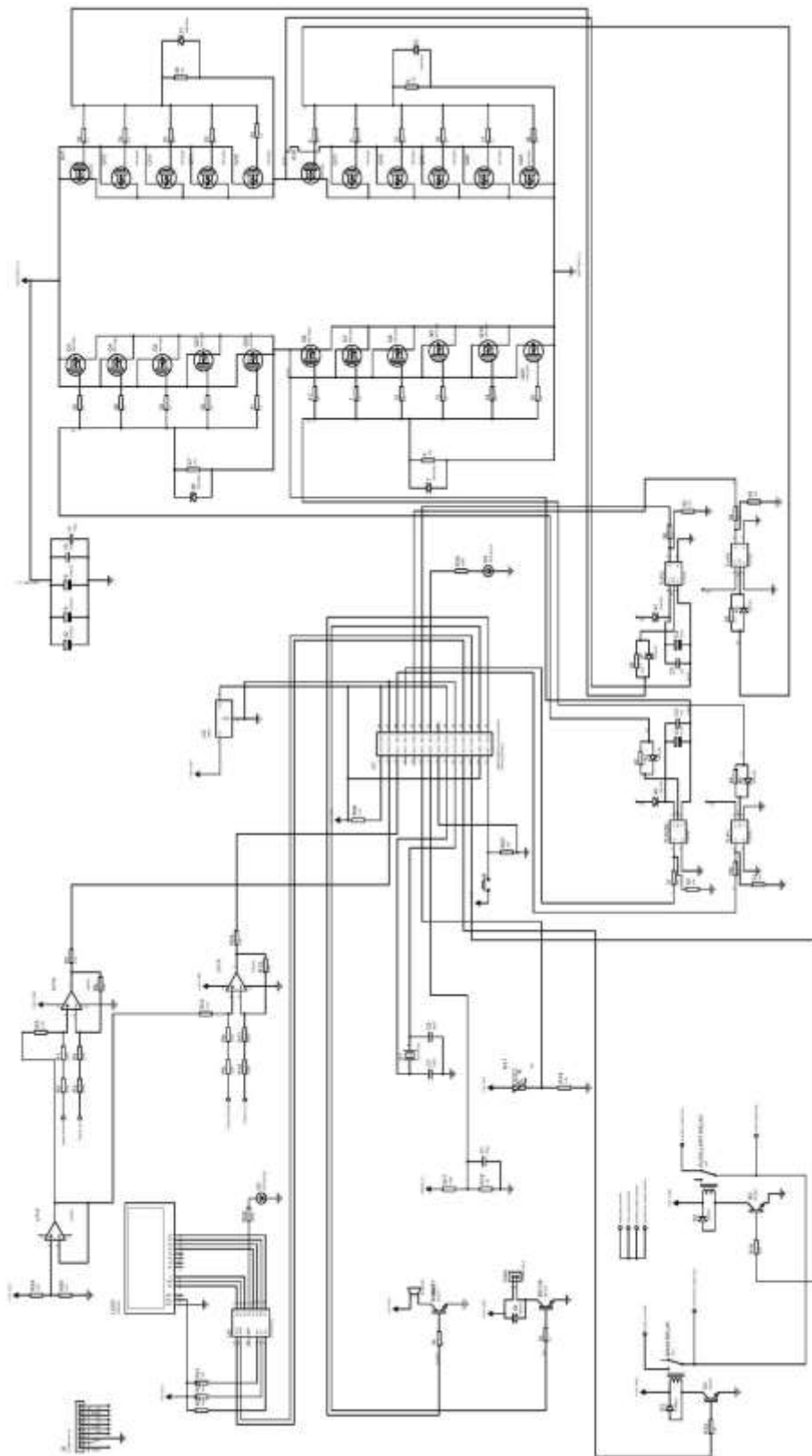

3.16: Complete Circuit Diagram of the Inverter

3.14 WORKING PRINCIPLE OF INVERTER

The operating principle of an inverter can be described as follows:

The inverter's working concept is similar to that of a switching power supply. It uses an oscillating chip or a specialized circuit to control the output of the oscillating signal, which is amplified to force the FET to flip continually. After adjustment, the AC characteristics of can produce a sine wave AC similar to the power grid.

A power survey device called an inverter is required for stand-alone solar systems that use AC loads. The size of the set DC voltage is a significant consideration when choosing an inverter. The inverter's output can be classified into two types: DC output and AC output. The inverter is known as a converter for DC output because it converts DC voltage to DC voltage so that it can provide the voltage required for the functioning of DC loads of various voltages.

In addition to output power and voltage, waveform and frequency should be addressed for AC output. Pay attention to the inverter's DC voltage requirements and the variation in the surge voltage it can withstand at the input end.

The gate drive circuit of the power switch tube can be controlled by a logic circuit or a dedicated control chip, a general-purpose single-chip microcomputer or a DSP chip, etc. The voltage regulation capability of the inverter output is possible. Using the bridge inverter as an example, the rated voltage of the AC bus output by the inverter should be 10%–20% lower than the rated voltage of the DC bus (the purpose is to make It has certain stability).

The inverter is then controlled by PWM to provide a margin whose amplitude may be varied from 10% to 20%, and the modification from low to high is not limited; simply reduce the PWM on-duty ratio. As a result, the input DC voltage fluctuation range of the inverter is - 15 percent to 20%. It is not limited as long as the device's withstand voltage allows. Only the modest output pulse width needs to be adjusted (equivalent to chopping).

When the battery or solar cell output voltage is low, the inverter must be supplied with a booster. In the switching power supply mode, the circuit booster can raise the voltage, or the DC charge pump method can be utilized to enhance the voltage. The inverter boosts the voltage with the output transformer, so the inverter voltage matches the voltage of the battery or solar cell array, and the inverter outputs a lower AC voltage, which is then boosted by the power frequency transformer and fed into the distribution line.

It should be remembered that a portion of the energy will be wasted regardless of whether the transformer or the electronic circuit is boosted. The optimal inverter working mode is when the DC input voltage matches the transmission line voltage and the DC power only goes through one layer of inverter links to minimise conversion link loss. Generally speaking, the inverter's efficiency is greater than 90%. The thermal energy of the power tube and transformer is converted from the energy lost in the inverter link.

This heat is detrimental to the inverter's operation and poses a risk to the device's safety. To remove the heat from the device, a radiator, a fan, or other means must be used. Conduction loss and switching loss are usually two elements of inversion loss.

The MOSFET has a high switching frequency and a significant on-resistance, and the inverter it is used in operates at a frequency of tens to hundreds of kilohertz; the IGBT, on the other hand, has a tiny conduction voltage drop, a moderate switching loss, and a switching frequency. The frequency ranges from several thousand to tens of kilohertz, with the average being fewer than ten kilohertz.

The switch isn't exactly great. The current rises during the turn-on operation, while the tube terminal voltage falls. The turn-on loss occurs when the voltage and current are crossed, and the turn-off loss occurs when the voltage and current are crossed in the other direction. The primary goal of inverter loss reduction is to reduce switching loss. The novel resonant switching inverter reduces switching loss by turning on or off at the zero-crossing point of voltage or current.

The single-phase bridge inverter circuit, as shown in Figure 1-2, will be used to demonstrate the basic operating concept of the inverter circuit (a). The switches S1 to S4 are made up of power electronic devices and auxiliary circuits and are situated on the four arms of the bridge circuit.

CHAPTER FOUR

CONSTRUCTION, TESTING, AND ANALYSIS

4.1 CONSTRUCTION

The construction process of this inverter involved assembling various electrical and electronic components in a precise manner to ensure flawless operation according to specifications. Some components were procured from local electrical and electronics stores, while others were in discrete or integrated form. The transformer used was locally fabricated using available raw materials.

In line with the inverter block diagrams presented in chapters two and three, the construction was carried out in distinct stages. Initially, the 3.5KVA transformer was securely attached to the casing's base. This transformer choice was a safety precaution, ensuring that even after accounting for losses, a 3.5KVA output capacity could be maintained.

Subsequently, the MOSFETs bank was affixed to heat sinks to facilitate efficient cooling. A temperature sensor was also attached to the heat sinks to monitor transistor temperatures, enabling control of the cooling fan. The control unit was positioned atop the MOSFETs bank with proper spacing to aid in directing cooling air throughout the bank. All necessary connections between individual sub-circuits were meticulously established, and components such as the cooling fan, output filter capacitors, and connecting terminals were installed as per the design.

Various phases of the project underwent testing, ensuring appropriate spacing and positioning of components were prioritized. The project was designed to accommodate load variations without adversely affecting the inverter circuit. This flexibility was achieved by using a 3.5KVA transformer, providing a 20% safety margin, which means the inverter's capacity could be upgraded to deliver more power output, up to 3.5KVA. The number of MOSFETs used and the transformer's rating underscored this capability.

The construction also relied on a range of tools and materials, which includes:

- i-**A digital multimeter
- ii-**Cutters
- iii-**Soldering iron and lead

- iv**-Long nose and short nose pliers
- v**-Copper clad boards
- vi**-A set of screwdrivers
- vii**-Lead suckers
- viii**-Glue gun and wax
- ix**-Angle grinder
- x**-Electric drilling machine
- xi**-A mini drilling machine for PCBs, among others.

4.1.1 CONSTRUCTION OF CONTROL STAGE

The construction of the control stage involved designing and extracting the control PCB (as shown in Figure 3.16) in PDF format. The design was then transferred onto a copper clad board of the same dimensions by using a pressing iron to transfer the prints. Although a laminating machine could have been used for a simpler and safer heat transfer process, we opted for the pressing iron method to save costs associated with using the laminating machine.

The PCB etching process was carried out using ferric chloride in a displacement reaction. As copper is more electro-positive than iron, it displaced the iron from the salt, resulting in the formation of copper (II) chloride. Residues of the displaced iron were left in the solution.

4.1.2 CONSTRUCTION OF MOSFET STAGE

The construction of the MOSFET stage followed a similar process to that of the control PCB. The MOSFET bank consists of 16 MOSFETs, grouped in sets of four to form the four-switching arms of the H-bridge configuration. Additionally, capacitors are included in the design for energy storage during charging and to suppress ripple current.

Due to their nature as power devices, the MOSFETs are attached to heat sinks to handle the inevitable heat generation. In chapter two, we explained the reasoning behind using four

MOSFETs on each side, based on calculations. This decision was made to reduce conduction losses and improve overall efficiency.

The MOSFET bank PCB is securely mounted at the base of the casing using bolts and nuts to ensure a strong and stable connection. The input DC power from the batteries directly goes to this stage where the conversion (inversion) from DC to AC takes place. Additionally, power is distributed from this section to the control section, and modulating signals from the control section are sent to drive the MOSFETs.

4.1.3 BUILDING THE TRANSFORMER

Before achieving the desired design for the transformer, several crucial factors had to be taken into account. When designing a transformer that utilizes sine or square waves, it is essential to have knowledge of the incoming line voltage, operating frequency, secondary voltage, secondary current, permissible temperature increase, target efficiency, allowable physical dimensions, and cost constraints.

The design parameters established in previous sections have already been met, providing guidelines for the construction of the 3.5KVA transformer. The decision to acquire a 5kVA stabilizer transformer was motivated by the following considerations:

- i-**An automatic voltage stabilizer transformer boasts approximately double the power capacity when compared to its use as a single-phase transformer with complete isolation between the primary and secondary sides. This is due to the fact that an automatic voltage stabilizer transformer functions as an auto-transformer, rendering it more powerful than its conventional counterpart of the same size.
- ii-**According to the Alfred Babani equation, a conventional 5KVA version yielded a maximum output of approximately 1800W.

4.2 EVALUATION

The circuit underwent testing to verify that the essential components functioned as anticipated. The tests conducted were as follows:

4.2.1 ASSESSMENT OF TRANSFORMER IN OPEN CIRCUIT CONDITION

This examination was conducted to ensure that the output voltage and power loss aligned with the specified requirements, aiming for optimal circuit performance.

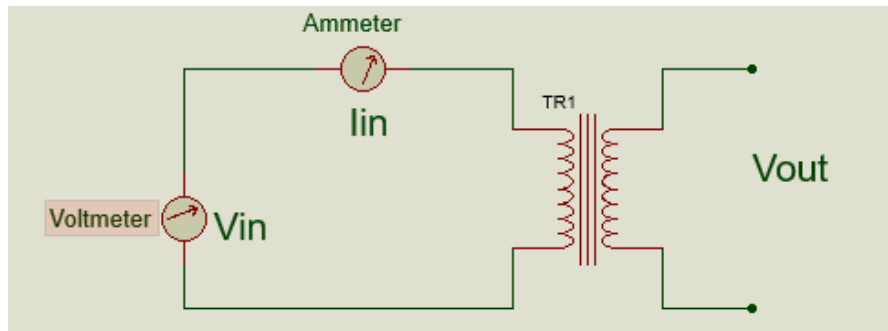

Figure 4.1: Schematic Diagram of the open circuit test

Table 4.1. Transformer Open Circuit Test

S/N	V _{in} (volts)	V _{out} (volts)	I _{in} (amps)
1	0.00	0.00	0.00
2	50.00	3.21	0.05
3	80.00	5.12	0.08
4	120.00	7.57	0.12
5	160.00	10.01	0.16
6	180.00	11.27	0.18
7	200.00	12.58	0.20
8	210.00	13.13	0.21

9	220.00	13.28	0.24
10	230.00	14.51	0.25

4.2.2 Transformer Short Circuit Test

In this test, the primary was supplied with 5 to 10% of the typical input voltage, and the secondary was shorted. Below is a diagram for the transformer open circuit test:

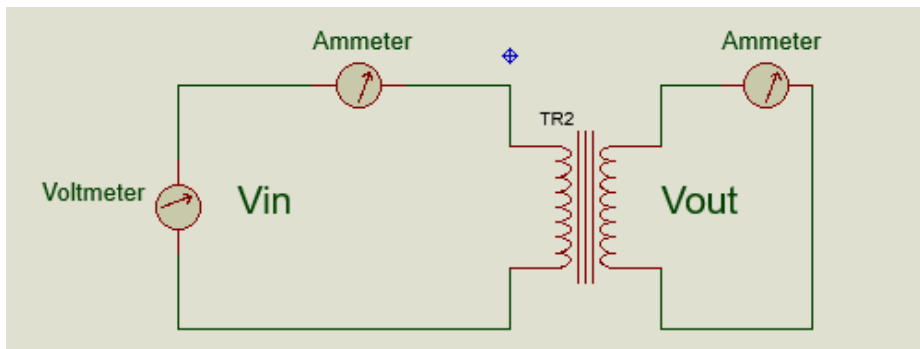

Figure 4.2. Schematic Diagram for the short circuit test

Table 4.2. Transformer Short Circuit Test

S/N	V _{in} (volts)	V _{out} (volts)	I _{Sin} (Amps)	I _{Sout} (Amps)
1	0.00	0.00	0.00	0.00
2	10.00	0.00	15.2	16.1
3	15.00	0.00	20.2	22.7
4	20.00	0.00	25.6	31.7

5	30.00	0.00	47.9	53.5
6	50.00	0.00	83.5	91.2

4.2.3 INVERTER LOAD TEST

This test was carried out to ensure the inverter functions as expected to output stable voltage under load conditions. The test results are given below:

Table 4.3. Inverter Load Test results

S/N	V _{battery} (V)	I _{battery} (A)	V _{out} (V)	I _{out} (A)	Load (W)
1	26.6	4.5	220.0	0.45	100
2	26.5	9.1	222.0	0.90	200
3	26.2	18.5	220.0	1.80	400
4	25.9	28.5	220.0	2.70	600
5	25.3	39.2	220.0	3.60	800
6	24.9	45.2	219.9	4.09	900
7	24.5	51.8	219.8	4.55	1000
8	24.1	62.7	219.2	5.47	1200
9	23.9	81.5	218.5	6.86	1500
10	23.5	97.0	217.3	8.28	1800

4.3 ANALYSIS OF RESULT

During the testing of the load it was observed that the output voltage was stable to 900W loading and experienced a steady but negligible drop as the load increased to 1800W. The difference in the voltage finally amounted to a final value of 2.7V at 1800W which makes the inverter superefficient.

4.4 BILL OF ENGINEERING MANAGEMENT AND EVALUTION

Table 4.4: Bill of engineering measurement and evaluation

S/N	DESCRIPTION OF ITEMS	QUANTITY	UNIT RATE (₦)	TOTAL AMOUNT (₦)
1	3.5KVA transformer	1	50,000	50,000
2	DSPIC30F4012	1	15,000	15,000
3	TLP250 MOSFET drivers	4	5,000	20,000
4	Heat Sink	5	1,000	5,000
5	Copper clad board	1	8,000	8,000
6	LM324N Op-Amp	1	1,000	1,000
7	Irf3205 MOSFETs	24	500	12,000
8	Relay	2	1,000	2,000
9	Buzzer	1	500	500
10	Ribbon Cables	2	1,000	2,000
11	EE25 ferrite transformer	1	2,000	2,000
12	Copper Wires	9.5 (Kg)	15,000	142,500
13	Casing	1	15,000	15,000
14	12V DC Fan	1	500	500
15	175A DC Breaker	1	8,000	8,000

16	16A AC Breaker	1	3,500	3,500
17	Switch	1	400	400
18	10A Current transformer	1	3,500	3,500
19	Resistors (all varieties used)	100	50	5,000
20	Capacitors (all varieties used)	30	50	1,500
21	6.144Mhz Crystal	1	300	300
22	DIP IC Sockets	7	200	1400
23	Diodes	10	300	3,000
24	UC3843	1	400	400
25	Connecting AC wires	2 (yards)	600	1200
26	16MM DC Cables	3 (yards)	1,500	4,500
27	Connectors	1 (Row)	600	600
28	CD4045	1	500	500
29	Buttons	4	100	400
30	BJT Transistors	3	150	450
31	Etchant	1	3,000	3,000
32	Cable Lock	5	200	1000
33	NTC sensor	1	800	800
34	CD4098	2	1,500	3,000
35	LCD	1	8,000	8,000
36	SCHOTSKY DIODE	10	300	3000
37	BATTERY TERMINALS	2	2,000	4,000
38	4N35 OPTOCOUPLER	2	450	900

39	POWER PLUG	1	500	500
40	7805 5V REGULATOR	1	250	250
41	FUSE AND SOCKET	1	200	200
42	TAPE	1	250	250
TOTAL				335,050

CHAPTER FIVE

LIMITATIONS, CONCLUSION AND RECOMMENDATION

5.1 LIMITATION OF THE STUDY

- i-**Complicated controlling process.
- ii-**Appliances that are connected may have restrictions depending on the hybrid inverter's kind and capabilities.
- iii-**A larger, more sophisticated installation costs more to install and requires more space.
- iv-**A low amount of sunlight during the day can affect the extent to which the battery is charged.
- v-**Solar energy can be harnessed only at those places which get plenty of sunlight.
- vi-**Solar energy cannot be harnessed beyond certain latitudes.
- vii-**Solar cannot be harnessed during night.
- viii-**Current technologies are very costly.
- ix-**During cloudy weather, less power is being generated.

5.2 CONCLUSION

The design and construction of the 3.5KVA hybrid inverter, powered by a 24V DC battery to generate a 220V output voltage, were successfully completed. The primary goal of this project, which aimed to establish an alternative power supply, has been accomplished.

In Chapter 2 of our research, we delved into the operational principles of inverter designs. Subsequently, in Chapter 3, we performed calculations to determine the necessary values for generating a circuit diagram for the 3.5KVA inverter, complete with a comprehensive circuit plan.

Remarkably, the system exhibited minimal losses, as evidenced by the inverter's ability to power a 1800W load with only a slight decrease of 2.7V in the output voltage. This translates to an impressive 81% efficiency even under heavy loading conditions.

To efficiently manage the inverter's operation, we incorporated the DSPIC30F4012 microcontroller, which effectively controls the relays for load management, ensuring that power is supplied or cut off when the battery level drops below a certain threshold.

One notable feature of this DC to AC inverter is its capability to produce a pure sine wave output voltage. This achievement is attributed to the utilization of MOSFET transistors as electronic switches, resulting in exceptionally high conversion efficiency and stable amplitude. This sine wave output is crucial because it aligns with the requirements of most appliances, making it a key objective in our inverter design.

Several valuable conclusions can be drawn from our work, including:

- The output waveform frequency of 50Hz closely matches the standard frequency of the Nigeria Power System, meeting operational expectations.
- The application of DSPIC30f2010 microcontroller greatly simplifies the sine pulse width modulation circuit.
- Additionally, the high programming flexibility afforded by the microcontroller allows for easy modification of switching pulse designs without the need for hardware alterations. A few code adjustments suffice for this purpose.

5.3 RECOMMENDATION

The following recommendations stem from the testing and practical implementations conducted within the scope of this project. In order to alleviate the load and attain a pure sine wave output, the high-frequency approach presents itself as a viable alternative.

1. This approach not only proves to be more efficient but also significantly reduces overall costs.
2. The high-frequency method involves an initial step of up-converting the low-voltage DC to high-voltage DC by utilizing high-frequency DC to DC converters.
3. Subsequently, this elevated voltage is directed to the H-bridge (comprising MOSFETs), and through the application of high-quality pulse width modulation, it is transformed into "chopped" AC.
4. This AC is then subjected to an L-C low pass filter, resulting in the production of a pristine 50Hz sine wave output.

By adopting this approach, the system's efficiency will experience a substantial enhancement, primarily due to the reduction in losses that it offers.

REFERENCES

1. Tovar-Facio, Javier, et al. "Management of Renewable Energy Sources." *Sustainable Design for Renewable Processes*, 2022, pp. 3–31
2. Olusola Bamisile, et al. "A review of renewable energy potential in Nigeria; solar power development over the years." (2017). *Engineering and Applied Science Research*, 44(4), 242–248.
3. Sarfraz, M., Naseem, S., & Mohsin, M. (2022). Adoption of renewable energy, natural resources with conversion information communication technologies and environmental mitigation: Evidence from G-7 countries. *Energy Reports*, 8, 11101–11111. <https://doi.org/10.1016/j.egy.2022.08.248>
4. Razi, M., & Ali, Y. (2018). Ranking renewable energy production methods based on economic and environmental criteria using multi-criteria decision analysis. *Environment Systems and Decisions*, 39(2), 198–213. <https://doi.org/10.1007/s10669-018-9713-6>
5. Elehinafe, F. B., et al. "Energy Status, Energy Mix and Renewable Energy Potentials of Nigeria." *Energy and Environment Research*, vol. 11, no. 1, 20 May 2021, p. 50, <https://doi.org/10.5539/eer.v11n1p50>. Accessed 28 July 2021
6. Brent, Alan Colin. "Renewable Energy for Sustainable Development." *Sustainability*, vol. 13, no. 12, 19 June 2021, p. 6920, <https://doi.org/10.3390/su13126920>. Accessed 8 July 2021
7. Bauer, G. H. (2015). Sun as Energy Source. *Typeset.io*, 9–37. https://doi.org/10.1007/978-3-662-46684-1_3
8. Megantoro, Prisma, et al. "Effect of Peak Sun Hour on Energy Productivity of Solar Photovoltaic Power System." *Bulletin of Electrical Engineering and Informatics*, vol. 11, no. 5, 1 Oct. 2022, pp. 2442–2449, <https://doi.org/10.11591/eei.v11i5.3962>. Accessed 30 Jan. 2023.

9. Adalakun, Najeem Olawale, and Banji A. Olanipekun. "A Review of Solar Energy." *SSRN Electronic Journal*, 2019, <https://doi.org/10.2139/ssrn.3579939>. Accessed 6 June 2020.
10. Johansson, Erik M. J., and Aneta Andruszkiewicz. "Combining Quantum Dot and Perovskite Photovoltaic Cells for Efficient Photon to Electricity Conversion in Energy Storage Devices." *Energy Technology*, vol. 10, no. 10, 6 Sept. 2022, p. 2200598, <https://doi.org/10.1002/ente.202200598>. Accessed 27 Dec. 2022
11. Kanotra, Mehul, et al. "Intelligent Photovoltaic Panels Based on Solar Tracking." *Journal of Information and Optimization Sciences*, vol. 41, no.1, 2 Jan. 2020, pp. 129–141, <https://doi.org/10.1080/02522667.2020.1715563>. Accessed 24 Feb. 2023.
12. Abdelhady, Salama, et al. "An Understanding of the Operation of Silicon Photovoltaic Panels." *Energy Procedia*, vol. 113, May 2017, pp. 466–475, <https://doi.org/10.1016/j.egypro.2017.04.041>. Accessed 22 Feb. 2021
13. Tayagaki, Takeshi, et al. "Comparative Study of Power Generation in Curved Photovoltaic Modules of Series- and Parallel-Connected Solar Cells." *IEEE Journal of Photovoltaics*, vol. 11, no. 3, May 2021, pp. 708–714, <https://doi.org/10.1109/jphotov.2021.3060399>. Accessed 12 Aug. 2022.
14. Ran, Siyuan, et al. "A Solar-Air Hybrid Source Heat Pump for Space Heating and Domestic Hot Water." *Solar Energy*, vol. 199, Mar. 2020, pp. 347–359, <https://doi.org/10.1016/j.solener.2020.02.038>. Accessed 14 Apr. 2022.
15. Sharma, Vinod Kumar, et al. "Imperative Role of Photovoltaic and Concentrating Solar Power Technologies towards Renewable Energy Generation." *International Journal of Photoenergy*, vol. 2022, 29 Jan. 2022, pp. 1–13, <https://doi.org/10.1155/2022/3852484>. Accessed 15 Mar.
16. Zainurin, N. A., et al. "A Review of Battery Charging - Discharging Management Controller: A Proposed Conceptual Battery Storage Charging – Discharging Centralized Controller." *Engineering, Technology & Applied Science Research*, vol. 11, no. 4, 21 Aug. 2021, pp. 7515–7521, <https://doi.org/10.48084/etasr.4217>. Accessed 13 Oct. 2021022.
17. Hoyos Velasco, Fredy E., et al. "DC-AC Power Inverter Controlled Analogically with Zero Hysteresis." *International Journal of Electrical and Computer Engineering (IJECE)*, vol. 9, no. 6, 1 Dec. 2019, p. 4767, <https://doi.org/10.11591/ijece.v9i6.pp4767-4776>. Accessed 20 Mar. 2020.

18. Shahparasti, Mahdi, et al. "Toward Power Quality Management in Hybrid AC-DC Microgrid Using LTC-L Utility Interactive Inverter: Load Voltage-Grid Current Tradeoff." *IEEE Transactions on Smart Grid*, 2015, pp. 1–11, <https://doi.org/10.1109/tsg.2015.2480717>. Accessed 18 Aug. 2021.
19. Choi, Yong-Eun, et al. "PV Inverter Output Characteristics according to Deterioration of DC Link Capacitor." *The Transactions of the Korean Institute of Electrical Engineers*, vol. 71, no. 10, 31 Oct. 2022, pp. 1505–1511, <https://doi.org/10.5370/kiee.2022.71.10.1505>. Accessed 28 Nov. 2022
20. Puukko, J., and T. Suntio. "Dynamic Properties of a Voltage Source Inverter-Based Three-Phase Inverter in Photovoltaic Application." *IET Renewable Power Generation*, vol. 6, no. 6, 1 Nov. 2012, pp. 381–391, <https://doi.org/10.1049/iet-rpg.2011.0302>. Accessed 31 Oct. 2019.
21. Catur Rakhmad Handoko. "Sine Wave Inverter Bipolar SPWM Using Analog Triggering Circuit." *International Journal of Engineering Research And*, vol. V8, no. 03, 30 Mar. 2019, <https://doi.org/10.17577/ijertv8is030197>. Accessed 13 Aug. 2022
22. Ruiz-Gonzalez, Antonio , et al. "Pulse Width Modulation Technique with Harmonic Injection in the Modulating Wave and Discontinuous Frequency Modulation for the Carrier Wave to Reduce Vibrations in Asynchronous Machines." *IET Power Electronics*, vol. 12, no. 11, 15 Aug. 2019, pp. 2865–2872, <https://doi.org/10.1049/iet-pel.2018.5178>. Accessed 9 May 2022.
23. Ahmed, Nasim, and Ziaur Rahman Khan. "Microcontroller Based Pure Sine Wave Inverter." *2021 IEEE International Conference in Power Engineering Application (ICPEA)*, 8 Mar. 2021, <https://doi.org/10.1109/icpea51500.2021.9417841>. Accessed 17 Dec. 2022
24. Hassan, Aakash, et al. "An Improved Genetic Algorithm Based Fractional Open Circuit Voltage MPPT for Solar PV Systems." *Energy Reports*, vol. 9, Dec. 2023, pp. 1535–1548, <https://doi.org/10.1016/j.egy.2022.12.088>. Accessed 4 Mar. 2023.
25. Mirzaei, Amin, et al. "Design and Construction of a Charge Controller for Stand-Alone PV/Battery Hybrid System by Using a New Control Strategy and Power Management." *Solar Energy*, vol. 149, June 2017, pp. 132–144, <https://doi.org/10.1016/j.solener.2017.03.046>. Accessed 20 Feb. 2022
26. Coltman, J.W. "The Transformer [Historical Overview]." *IEEE Industry Applications Magazine*, vol. 8, no. 1, Jan. 2002, pp. 8–15, <https://doi.org/10.1109/2943.974352>.

27. Mekhitarian, V. M. “The Faraday Law of Induction for an Arbitrarily Moving Charge.” *Journal of Contemporary Physics (Armenian Academy of Sciences)*, vol. 51, no. 2, Apr. 2016, pp. 108–126, <https://doi.org/10.3103/s1068337216020031>. Accessed 17 Mar. 2021.
28. Mishra, Vimal Kumar, and Nitu Rao. “Electrostatic Investigation of Intended Source Drain Ultra Thin Body FD-SOI MOSFET.” *Silicon*, vol. 12, no. 12, 14 Jan. 2020, pp. 2819–2827, <https://doi.org/10.1007/s12633-020-00377-6>. Accessed 14 Dec. 2020.
29. Roy, Ashim, et al. “Source–Drain Partitioning in MOSFET.” *IEEE Transactions on Electron Devices*, 29 May 2007, <https://doi.org/10.1109/ted.2007.895858>. Accessed 3 May 2023.
30. Musa, A, and G Galadanci. “5kVa Power Inverter Design and Simulation Based on Boost Converter and H-Bridge Inverter Topology.” *Bayero Journal of Pure and Applied Sciences*, vol. 2, no. 1, 26 Aug. 2010, <https://doi.org/10.4314/bajopas.v2i1.58448>. Accessed 11 June 2021.