

**DESIGN AND FABRICATION OF A PROTOTYPE PLATFORM SUPPLY
VESSEL**



BY

LAWANI JOHN TAIWO

ENG1805251

ARIAYE SUNDAY TARIBO

ENG1805231

AJUKWU-SUALIM MITCHEL

ENG1810282

ALUGE EDOSA EZEKIEL

ENG1910177

EDOSOMWAN OSAYUKI GLORY

ENG1905476

THE DEPARTMENT OF MARINE ENGINEERING,
FACULTY OF ENGINEERING,
UNIVERSITY OF BENIN, BENIN CITY, NIGERIA.

APRIL, 2024

**DESIGN AND FABRICATION OF A PROTOTYPE PLATFORM
SUPPLY VESSEL**



BY

LAWANI JOHN TAIWO

ENG1805251

ARIAYE SUNDAY TARIBO

ENG1805231

AJUKWU-SUALIM MITCHEL

ENG1810282

ALUGE EDOSA EZEKIEL

ENG1910177

EDOSOMWAN OSAYUKI GLORY

ENG1905476

**A PROJECT SUBMITTED IN PARTIAL FULFILMENT OF
REQUIREMENTS FOR THE AWARD OF BACHELOR OF ENGINEERING
(B.Eng.) DEGREE**

IN

THE DEPARTMENT OF MARINE ENGINEERING,

FACULTY OF ENGINEERING,

UNIVERSITY OF BENIN, BENIN CITY, NIGERIA.

APRIL, 2024

DEDICATION

This project work is dedicated to God Almighty who granted us courage and patience to perform and carry out this project work, and whom without his help we would not have achieved what we have done so far.

In addition, this project is dedicated to our parents for their great support, guidance, sacrifice and prayers throughout the duration of our course of study.

ACKNOWLEDGEMENTS

We would like to express our sincere thanks and gratitude to our project supervisor, Prof. E.G. Sadjere in recognition of his inspirational guidance and instruction during this project. Under his constant guidance, we were able to update this project phase. Regular reviews of the project work he performed helped us identify flaws in our work and set important milestones for this project.

We would like to extend our heartfelt appreciation to **Nicolas and Favour**, Sculpture majors in our Here University (University of Benin **Ekewahn** Campus), for their invaluable contributions to the creative aspects of this project.

Finally, we also want to thank our parents, who have always been next to us from the very first steps in life and helped us overcome all difficulties and hardships. Their encouragement, their love and our determination to make them proud have certainly been among our greatest sources of motivation. We would like to thank them very much for their support, both financial and otherwise.

TABLE OF CONTENTS

Title page	
Certification	i
Acknowledgement	ii
Abstract	iii
Table of Contents	iv
List of Tables	vii
List of Figures	ix
CHAPTER ONE	1
INTRODUCTION	1
1.1 Background to the study	1
1.3 Aims and Objectives of our Study	2
1.4 Scope of the Research	3
1.5 Significance of the Research	4
1.6 Advantages of the platform Supply Vessels (PSVs) over other vessels	4
1.7 Real life Application of Platform Supply Vessels (PSVs)	5
1.8 Methodology	8
CHAPTER TWO	9
LITERATURE REVIEW	9
2.1 Our Design Features	9
2.2 Students Contributions	10
2.3 Design Software Utilized	21
2.4 Previous Works	24
CHAPTER THREE	
MATERIALS AND METHODS	27
3.1 Materials	27
3.2 Structure	28
3.3 Electronics	31
3.4 Software	37

3.5 Functional Requirements	40
3.6 Methodology	41
3.7 Design Matrix	43
3.8 Detailed Design: Underwater Vehicle Frame	45
3.9 Bill of Engineering Materials and Evaluation (BEME)	51
CHAPTER FOUR	54
MATERIALS AND METHODS	54
4.1 Offset Table Result	54
CHAPTER FIVE	18
CONCLUSION AND RECOMMENDATIONS	18
5.1 Conclusion	58
5.2 Recommendation	58
Reference	57

LIST OF FIGURES

Figure 3.1: Fiberglass

Figure 3.2: Plastic propeller with 30cm shaft.

Figure 3.3: Resin

Figure 3.4: D3536 850kv Brushless DC motor.

Figure 3.5: A 40A ESC

Figure 3.6a: Male and Female Connectors

Figure 3.7: Servo

Figure 3.8: 2.4Ghz 4CH Radio Transmitter

Figure 3.9: 11.1v Li-polymer Battery charger.

ABSTRACT

The essence of this project lies in the creation of a prototype that serves as an educational tool, offering a tangible insight into the world of offshore logistics. This prototype, a scaled-down version of a Platform Supply Vessel (PSV), is designed to mimic the functionalities of a real PSV. The highlight of this educational resource is its physical design. The prototype features a distinctive hull design and bow shape, mirroring those of a real PSV. These elements not only add to its visual appeal but also play a crucial role in optimizing performance. Thus, this prototype stands as a unique innovation in the realm of educational resources for offshore logistics.

CHAPTER ONE

INTRODUCTION

1.1 Background to the Study

The Platform Supply Vessel (PSV) evolved to meet the practical needs of offshore oil and gas exploration, requiring a specialized vessel to transport essential supplies, equipment, and personnel to offshore platforms. The development of the PSV was driven by industry requirements, technological advancements, and the aim to enhance efficiency and safety in offshore operations. Early attempts at supplying platforms involved repurposed vessels like fishing boats and barges, but the growing industry demanded a dedicated vessel design. PSVs were designed to navigate challenging seas, transport substantial cargo, and ensure safe transfers between the vessel and the platform. They accommodated drilling equipment, consumables, and personnel with a focus on stability and safety during loading and unloading. Factors such as increasing exploration demand, safety concerns, and technological advancements influenced the development of PSVs. In the late 1960s and early 1970s, true PSVs emerged with enhanced stability, efficient cargo handling equipment, and improved navigation systems. As offshore exploration went deeper, PSVs increased in size and capacity, incorporating advanced propulsion systems, weather monitoring technology, and dynamic positioning capabilities. Modern PSVs undertake specialized tasks like subsea construction, emergency response, firefighting, and environmental monitoring. They are remarkable examples of maritime engineering.

1.2 STATEMENT OF THE PROBLEM

Traditional bow designs were susceptible to wave slamming and hull damage, resulting in discomfort and costly repairs. To mitigate this, naval architects sought a bow shape that minimizes wave slamming and reduces damages.

Poor seakeeping performance and instability were also prevalent in traditional bow shapes, leading to an unpleasant sailing experience. To enhance stability, a bow shape that minimizes pitch and roll motions was sought.

Fuel efficiency was a concern as traditional bow shapes had higher wave resistance and increased fuel consumption. The XBow hull minimizes wave resistance and slamming forces, resulting in improved fuel efficiency and reduced emissions.

Traditional bow designs faced limitations in speed and maneuverability due to higher wave resistance and drag. The XBow hull reduces wave resistance and drag, enabling faster travel and improved efficiency.

Safety hazards, such as green water flooding the deck, were a concern. The XBow hull effectively diverts water away from the deck, reducing the risk of flooding, accidents, and injuries.

1.3 Aims and objectives of our research

1. Design a prototype model PSV with an X-Bow.
2. Fabricate or construct the designed PSV.
3. Test run the PSV and record result.

1.4 Scope of the research

A model Platform Supply Vessel (PSV) would primarily emphasize the following features:

1. **Hull Design:** The model should meticulously replicate the hull design of a real PSV, displaying its unique shape, structure, and features that contribute to stability, buoyancy, and performance in offshore conditions.
2. **Bow Shape:** Highlighting the distinctive bow shape of the PSV, which plays a crucial role in navigating through challenging sea conditions, minimizing resistance, and ensuring optimal hydrodynamic efficiency.
3. **Scale Accuracy:** Ensuring that the model accurately represents the scale proportions of a real PSV, allowing learners to grasp the vessel's size and dimensions in relation to its hull design.
4. **Materials and Construction:** Providing insights into the materials used in constructing the hull and the overall vessel, emphasizing their durability and suitability for offshore environments.
5. **Stability Features:** Illustrating any specific stability features incorporated into the hull design, that contribute to the vessel's stability during loading, unloading, and navigation.
6. **Interactive Components:** Incorporating interactive elements that allow learners to explore and understand how the hull design influences the vessel's performance in different sea conditions.
7. **Educational Information:** Accompanying the model with educational information about the significance of the hull design, how it contributes to the vessel's overall functionality, and the considerations taken into account during the design process.

By concentrating on these aspects, the model PSV serves as a targeted learning tool, offering valuable insights into the key elements of hull design and form. This approach allows learners to focus on and appreciate the engineering intricacies that contribute to the PSV's success in offshore logistics and operations.

1.5 Significance of the research

Here are some key aspects of its significance:

1. **Educational Tool:** The model serves as a hands-on educational tool for students, professionals, and enthusiasts interested in maritime engineering, naval architecture, and offshore logistics. It provides a tangible representation of theoretical concepts, allowing for a deeper understanding of the vessel's design principles.
2. **Focused Learning:** By concentrating on the hull form and design, the model allows learners to delve into the specific features that contribute to the vessel's stability, performance, and efficiency. This focused learning approach enhances comprehension and retention of key engineering concepts.
3. **Visual Representation:** The model offers a visual representation of the intricate details of a PSV's hull, enabling learners to see and appreciate the real-world application of theoretical knowledge. This visual aid facilitates a more holistic understanding of the vessel's design.
4. **Engineering Appreciation:** Creating such a model encourages an appreciation for the engineering complexities involved in designing vessels for offshore environments. Learners gain insights into the considerations, challenges, and innovations that engineers face in creating maritime structures.
5. **Practical Application:** The model provides a practical and interactive means of applying theoretical knowledge. Learners can explore the implications of different hull designs on stability, maneuverability, and overall vessel performance in varying sea conditions.

6. **Industry Relevance:** Understanding the significance of hull form and design is crucial in the maritime and offshore industries. Professionals in shipbuilding, naval architecture, and offshore logistics can benefit from a tangible representation that enhances their comprehension of key design principles.
7. **Innovation and Design Exploration:** The creation of a model encourages innovation and exploration in design. It allows for experimentation with different hull shapes and forms, fostering creativity and problem-solving skills among learners interested in the field.
8. **Career Development:** For individuals pursuing careers in maritime engineering or related fields, working on or studying such a model can contribute to career development. It provides practical experience and a tangible representation that can be valuable in interviews and professional discussions.

1.6 Advantages of the Platform Supply Vessels (PSVs) over other vessels:

Platform Supply Vessels (PSVs) hold distinct advantages over other vessels, specifically tailored to their function in supporting offshore operations. Here are key advantages in terms of function:

1. **Dedicated Cargo Capacity:** PSVs are designed with large and open deck spaces, equipped with specialized cargo-handling systems. This allows them to efficiently transport and deliver various types of cargo, including drilling equipment, consumables, and personnel, making them ideal for offshore logistics.
2. **Dynamic Positioning (DP) Systems:** PSVs often feature DP systems that enable precise positioning without the need for anchors. This is essential for safe and stable operations in proximity to offshore platforms, where maintaining a specific position is critical.
3. **Efficient Loading and Unloading:** The design of PSVs facilitates efficient loading and unloading operations. Their open deck configurations, coupled with specialized cranes and

equipment, streamline cargo-handling processes, ensuring swift transfers between the vessel and the platform.

4. **Versatility in Operations:** Beyond cargo transport, PSVs are versatile and can be deployed for various functions, including subsea construction, maintenance, emergency response, firefighting, and environmental monitoring. This versatility makes them adaptable to diverse offshore tasks.
5. **Enhanced Stability:** PSVs are engineered for stability, featuring hull designs that provide increased stability in challenging sea conditions. This stability is crucial for ensuring the safety of cargo, personnel, and equipment during transit and operations.
6. **Advanced Navigation Systems:** Equipped with advanced navigation systems, PSVs can navigate through intricate offshore environments with precision. This contributes to safe and efficient operations, especially when maneuvering in close proximity to offshore platforms.
7. **Weather Tolerance:** The robust design of PSVs enables them to operate in adverse weather conditions common in offshore areas. Their resilience to rough seas ensures continued functionality, even when faced with challenging weather.
8. **Tailored Crew Accommodations:** PSVs often feature well-designed and comfortable accommodations for the crew. This is essential for optimizing crew well-being during extended periods at sea, ensuring that the vessel can operate effectively.
9. **Reduced Environmental Impact:** PSVs typically incorporate advanced environmental monitoring systems, aligning with industry efforts to minimize the effect of offshore operations. This focus on sustainability enhances their function with an eco-friendly approach.
10. **Optimized for Offshore Logistics:** The overall design and functionality of PSVs are optimized for the specific demands of offshore logistics. Their ability to efficiently transport

cargo, support various operations, and adapt to dynamic offshore conditions makes them well-suited for their intended function.

1.7 Real life Applications of Platform Supply Vessels (PSVs)

While their name might suggest a singular focus on delivering supplies, Platform Supply Vessels (PSVs) are true jacks-of-all-trades in the demanding world of offshore operations. Their robust design, versatile capabilities, and specialized equipment make them invaluable assets for a wide range of tasks beyond simply ferrying cargo to platforms. Let us dive into the diverse applications of these maritime workhorses:

1. **Logistical Backbone:** PSVs serve as the essential link between onshore facilities and offshore platforms, transporting supplies, equipment, and personnel with precision and efficiency.
2. **Dynamic Precision:** Equipped with advanced dynamic positioning systems, PSVs maintain stable positions near platforms without the need for anchors, ensuring safe and controlled operations.
3. **Subsea Construction and Maintenance:** Expertly deploying divers, ROVs, and other equipment, PSVs enable efficient subsea operations for inspection, maintenance, repair, and construction projects.
4. **Construction Catalysts:** PSVs contribute to offshore infrastructure development by transporting and positioning anchors, pipelines, and production modules.
5. **Emergency Sentinels:** PSVs are prepared for emergencies with firefighting capabilities and equipment for oil spill containment and rescue operations for personnel and environmental protection.

6. **Environmental Monitors:** PSVs collect vital environmental data, monitoring water and air quality, and studying marine life activity for informed environmental management and regulatory compliance.
7. **Offshore Wind Pioneers:** Adapting to the offshore wind industry, PSVs play a crucial role in handling specialized components and supporting installation operations.
8. **Scientific Research Vessels:** PSVs are versatile platforms for various scientific studies, accommodating specialized equipment for oceanographic research, marine biology studies, and underwater exploration.
9. **Decommissioning Dignitaries:** As offshore platforms near the end of their operational lifespan, PSVs support the safe and efficient decommissioning process, transporting personnel and equipment for dismantling tasks.

1.8 METHODOLOGY

The methods adopted for achieving the aim and objectives of this work are as follows:

1. Literature review of the research.
2. Feasibility studies
3. Conceptual design and preliminary testing.
4. Detailed design of the prototype
5. Fabrication of the prototype
6. Testing and review of the performance of the prototype
7. Conclusion and recommendation

CHAPTER 2

LITERATURE REVIEW

2.1 OUR DESIGN FEATURES

- **Deck:** The deck is the primary surface structure of the vessel, designed to carry equipment and supplies for offshore operations. It is engineered for efficient loading and offloading.
- **Cargo Holding Spaces and Tanks:** These are specialized compartments designed to hold various types of cargo. They include tanks for drilling mud, pulverized cement, diesel fuel, potable and non-potable water, and chemicals used in the drilling process.
- **Bridge:** The bridge, or wheelhouse, is the command center of the vessel. It houses the navigational and operational controls.
- **Hull:** The hull is the watertight body of the ship. It provides buoyancy and houses the cargo and machinery spaces.
- **Machinery Spaces:** These dedicated compartments house the ship's main propulsion machinery, auxiliary systems, and other mechanical and electrical equipment.
- **Bow & Stern:** The bow (fore end) and stern (aft end) of the vessel are designed to provide optimal hydrodynamic efficiency.
- **Keel:** The keel is a longitudinal structural element at the base of the hull, providing the backbone of the vessel. It contributes to the vessel's structural strength and stability.

❖ Steering Method

A rudder system functions by utilizing hydrodynamic principles to alter the directional stability and maneuverability of a watercraft. The rudder, typically situated at the stern, is controlled by a steering mechanism that allows it to pivot about a vertical axis. When the steering control is adjusted, the rudder's angle changes, modifying the flow of water passing by the vessel. This alteration in water flow generates hydrodynamic forces on the rudder, producing a turning moment that influences the vessel's heading.

❖ **Drive Type:**

Electric motors serve as the main source of propulsion, drawing power from onboard rechargeable batteries. When activated, the motors convert electrical energy from the batteries into rotational motion, which drives the propellers to generate thrust and propel the model ship through water.

2.2 Students' Contributions

ARIAYE Sunday Taribo

1. Produce an annotated diagram of a platform supply vessel (PSV) showing the position of the different components necessary for its operation.

ANNOTATED DIAGRAM OF A PLATFORM SUPPLY VESSEL (PSV)



Fig 1. Annotated Diagram of ship vessel

FUNCTIONS OF COMPONENTS

1.Working Deck:

Function: Provides a space for various operations such as loading and unloading cargo, equipment deployment, and other offshore activities.

2.X-bow:

Function: The X-bow design improves vessel performance in rough seas by reducing slamming and enhancing stability.

3.Steering Gear:

Function: Controls the vessel's direction by manipulating the rudder, allowing for navigation and course adjustments.

4.Propeller:

Function: Propels the vessel forward or backward by generating thrust when rotated.

5.Firefighting Monitor:

Function: Used for firefighting operations; it directs a stream of water or fire suppressant to control or extinguish fires on the vessel or in the vicinity.

6.MOB (Man Overboard) Boat:

Function: Provides a quick means of reaching and rescuing crew members who have fallen overboard.

7.Bridge:

Function: The command center of the vessel; it houses navigation equipment, controls, and communication systems for the crew to operate and navigate the vessel.

8.Mooring Bit:

Function: Used for securing mooring lines, which are essential for anchoring or station-keeping.

9.Rescue Zone:

Function: A designated area for executing search and rescue operations, typically equipped with necessary tools and equipment.

10.Stern keel:

Function: Located at the back of a ship it helps stabilize the ship and improve its maneuverability.

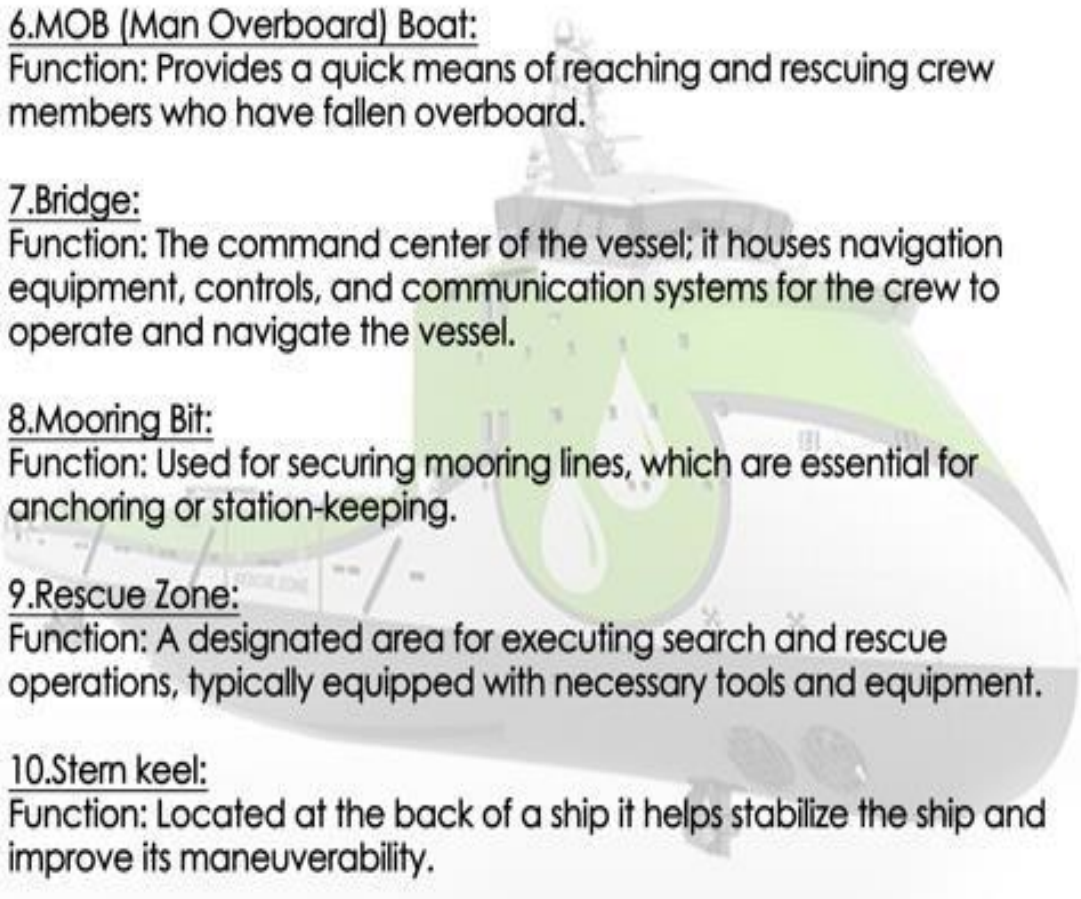

FUNCTIONS OF COMPONENTS

11. Propeller Shaft:

Function: Transmits power from the main engines to the propeller, enabling propulsion.

12. Antennas:

Function: Transmit and receive communication signals, including radio, navigation, and satellite communication.

13. Anchor Roller:

Function: Guides the anchor chain and assists in the deployment and retrieval of the vessel's anchor.

14. Anchor Windlass:

Function: A mechanical device used to raise or lower the vessel's anchor.

15. Azimuth Thruster:

Function: Provides additional thrust and maneuverability, especially during dynamic positioning and precise vessel control.

16. Ship Hull:

Function: The main body of the vessel that provides buoyancy and structural support.

17. Stern Tube:

Function: Houses the propeller shaft as it passes through the hull, maintaining a watertight seal.

18. Water Line:

Function: Indicates the level at which the vessel's hull meets the water surface.

These components collectively contribute to the safe and efficient operation of a Platform Supply Vessel.



LAWANI John Taiwo

Design the propeller for a platform supply vessel (PSV)500 hp and scale it down to a 1/2 hp motor. Design and explain the working of the thrusters and rudder.

WHAT IS A PROPELLER?

A propeller is a mechanical device designed to provide thrust and propel vehicles through a fluid medium, such as air or water. Comprising blades attached to a central hub, it operates on the principle of Newton's Third Law—action and reaction. In maritime contexts, propellers generate forward thrust by creating a flow of water, essential for the propulsion of ships and boats. Similarly, in aviation, propellers play a crucial role in piston-driven aircraft, producing lift and forward motion through the air. Propeller design, encompassing factors like blade shape, pitch, and materials, directly influences vehicle performance, emphasizing the significance of this fundamental component in various modes of transportation.

HOW DO PROPELLERS WORK?

First, the basics: do propellers push or pull through the water? The answer is both - similar to how a household fan draws air in the back and blows it out the front, as propellers rotate, they push water backward which creates space in the front water must rush in to fill. It both pulls water in and pushes it out to create forward thrust. Each blade has a pressure differential where the bottom of the blade creates positive pushing pressure and the top of the blade creates negative pulling pressure. Most propellers have three or four blades (although they can have many more) each of which create these forces simultaneously. Pulling water in and pushing it out at a higher speed creates thrust that moves a vessel through the water.

SHIP THRUSTERS

Function: Thrusters are auxiliary propulsion devices mounted on the sides or bow of a ship. They serve to enhance the ship's maneuverability, especially in tight spaces like harbors or during precise positioning.

Types: Common types include azimuth thrusters, tunnel thrusters, and retractable thrusters. Azimuth thrusters can rotate 360 degrees, providing versatile thrust.

Working Principle: Power Source: Thrusters are typically powered by electric motors or hydraulic systems.

Directional Control: Thrusters can be rotated or directed to generate thrust in any desired direction.

Usage: During maneuvers, the captain activates the thrusters on one side, creating lateral thrust to move the ship sideways or rotate it. **Benefits:** - Enhances maneuverability in confined spaces.
- Allows for precise positioning and docking.

RUDDER

Function: The rudder is a crucial component for steering the ship. It helps maintain the ship's course by altering the direction of the water flow.

Location: Usually located at the stern (rear) of the ship.

Working Principle: Hydrodynamic Force: As the rudder is turned, it creates a hydrodynamic force due to the flow of water.

Turning the Ship: Turning the rudder redirects this force, causing the ship to change direction. **Controlled by the Helm:** The ship's helm (steering wheel or control system) is connected to the rudder, allowing the captain to dictate the ship's course.

Benefits: Essential for navigation and course correction. - Enables the ship to respond to the captain's steering commands.

AJUKWU-SUALIM MITCHEL

3. Design a remote or tethered control for the platform supply vessel (PSV). This will involve modules for control. Explain the working of the module.

ESC (Electronic Speed Controller) – Manages and regulates the velocity of an electric motor/thruster. A dedicated ESC is necessary for each thruster.

Transmitter – This handheld device transmits radio signals that are received by the receiver in order to control the vehicle.

Receiver – The device installed in the vehicle that receives radio signals from the transmitter. It is also, where the ESCs are connected.

Channel Mixer – Utilized to combine signals from two separate channels, such as throttle and steering.



Fig 2. Speed Controller

These surface RC transmitters are primarily designed for controlling RC cars but are also suitable for operating RC boats, kayaks, and other vehicles. The trigger in the front is responsible for managing the throttle, while the wheel on the side is used for steering.

The receiver for these transmitters typically features two primary channels for speed and steering, as well as an additional auxiliary channel.

Directly controlling each thruster channel for differential thrust steering is not efficient with this type of transmitter, necessitating the use of channel mixing. While higher-end transmitters may have built-in programmable channel mixing capabilities, many basic models do not. If the transmitter lacks channel mixing, a separate channel is required.



Fig 3: ESC

As the Basic ESC does not include a built-in BEC, a separate power supply is needed to power the receiver. In this scenario, the receiver has a channel labeled "VCC", where the power supply should be linked.

When powering on the system, the transmitter should be activated before the receiver. Conversely, when shutting down, the transmitter should be turned off last after disconnecting the power from the receiver to prevent accidental activation of the thrusters due to random

noise interference. While some RC systems have a feature to prevent this, it is advisable to follow this practice as a precaution.

In most RC systems, specific functions are assigned to standard channels:

- a. **Channel 1:** Typically designated for throttle control. In electric vehicles, this channel sends signals to the Electronic Speed Controller (ESC) to regulate the motor's speed.
- b. **Channel 2:** Commonly used for servo control, particularly for steering. In RC cars and boats, channel 2 directs the movement of the steering servo, which controls the wheels or rudder.

Key points to remember:

- While standard assignments exist, some RC systems allow for customization of channel assignments through the transmitter's programming menu.
- Always consult the manual of your specific RC system to identify designated channel functions. The receiver ports will also be labeled to correspond with channel assignments.
- Despite the potential for channel swapping, the throttle function typically employs a different type of control stick on the transmitter compared to steering. The throttle stick usually features spring-loaded center return, while the steering stick may include ratchets to hold its position.

If uncertain about the channel assignments of your RC system, refer to the manual or check the receiver port labels for guidance.

ALUGE EDOSA EZEKIEL

4. Discuss the forces encountered by ships in the sea and how they overcome them.

Introduction:

The vastness of the open sea provides an awe-inspiring backdrop for maritime adventures, but it also presents a complex set of challenges for ships and their crews.

As vessels traverse the world's oceans, they encounter a diverse array of forces that test the limits of engineering and navigation. In this in-depth exploration, we will dissect the forces at play and delve into the intricate ways in which ships overcome these challenges, ensuring safe and efficient maritime travel.

□ Buoyancy: Mastering the Art of Floating

At the core of ship design lies the principle of buoyancy. Archimedes' principle dictates that an object immersed in a fluid experiences an upward force equal to the weight of the fluid it displaces. Ships are engineered to capitalize on this principle, with carefully crafted hulls that displace water in a manner ensuring the vessel's weight is counteracted. Engineers meticulously calculate the ship's draft, or how deep it sits in the water, to optimize buoyancy and maintain a stable, floating equilibrium.

□ Gravity: Balancing Weight for Stability

Gravity, an omnipresent force, constantly pulls ships toward the Earth's center. Maintaining stability in the face of this force requires a delicate balance. Ship designers strategically position the ship's center of gravity (CG) and center of buoyancy (CB), ensuring they align for optimal stability. Ballast tanks, strategically placed within the hull, can be filled with water to lower the CG or emptied to raise it, allowing the ship to adapt to changes in cargo load and sea conditions.

□ **Wind Forces: Sailing Through Challenges**

The force of the wind on a ship's sails can be both a blessing and a challenge. Traditional sailing vessels leverage the wind's force to propel them forward, adjusting sail angles to harness its power effectively. Modern ships, equipped with engines, face the challenge of wind-induced heeling or rolling. Stabilization technologies, such as retractable fins and gyroscopic systems, counteract these forces, ensuring a smooth and controlled ride even in challenging wind conditions.

□ **Wave Forces: Conquering the Ocean's Rhythm**

Waves, a constant presence at sea, introduce dynamic forces that can test a ship's structural integrity. Different types of waves, from gentle swells to powerful rogue waves, necessitate innovative hull designs. Bulbous bows, positioned at the front of the ship, reduce resistance and dampen pitching motions. Anti-rolling tanks, filled and emptied strategically, counteract the rolling forces induced by waves, providing a more stable ride for passengers and crew.

□ **Currents: Navigating the Fluid Highways**

Ocean currents, massive flows of water with varying speeds and directions, influence a ship's course and speed. Sophisticated navigation systems, including GPS and inertial navigation, help ships calculate and compensate for the effects of currents. Advanced propulsion systems, like azimuth thrusters and podded propulsion, enhance maneuverability, allowing vessels to navigate efficiently through currents and maintain their intended routes.

□ **Ice Forces: Breaking Through Arctic Challenges**

In Polar Regions, where icy waters present a unique set of challenges, ice forces come into play. Icebreakers, designed with reinforced hulls and powerful engines, plow through ice-covered waters. The sheer mass and strength of these vessels enable them to break through ice, ensuring safe passage and opening up routes in frozen environments.

EDOSOMWAN GLORY OSAYUKI

5. Discuss diesel engines and their use in a platform supply vessel (PSV). Discuss the functions of a platform supply vessel (PSV) in sea operations and their performance of these functions.

Diesel engines are commonly used in Platform Supply Vessels (PSVs) due to their efficiency, reliability, and fuel availability. Diesel engines provide high torque at low RPM, making them suitable for the varying speeds and power requirements of PSVs during sea operations. Platform Supply Vessels serve a crucial role in offshore operations, supporting oil and gas platforms.

Their functions include:

1. **Transportation of Supplies:** PSVs transport essential materials such as fuel, water, drilling fluids, and equipment from shore to offshore platforms.
2. **Crew Transport:** They facilitate the transfer of personnel between the shore and the platform, ensuring the timely rotation of crewmembers.
3. **Safety and Emergency Response:** PSVs are equipped with safety and emergency response equipment, including firefighting gear and life-saving appliances, contributing to the overall safety of offshore installations.
4. **Standby and Anchor Handling:** PSVs often serve as standby vessels, ready to assist in emergencies. They are also involved in anchor handling operations during platform positioning or relocation.
5. **Dynamic Positioning (DP):** PSVs use DP systems to maintain their position without traditional anchoring. This is crucial for precise maneuvering during loading and unloading operations.
6. **Supply and Waste Disposal:** PSVs handle the removal of waste generated on platforms and provide additional storage capacity for recovered oil or other substances.

2.3 DESIGN SOFTWARE UTILISED – RHINOCEROS™

Rhinoceros, colloquially known as Rhino, is a commercial 3D computer graphics and computer-aided design (CAD) application software. It was developed by the American company TLM, Inc., dba Robert McNeel & Associates, a privately held, employee-owned company that was founded in 1978. Rhino has become a standard in many industries due to its powerful and flexible modeling capabilities.

Rhino's primary strength lies in its use of Non-Uniform Rational Basis Spline (NURBS), a mathematical model that renders curves and surfaces in computer graphics. NURBS provides great flexibility and precision, making it ideal for representing freeform shapes. This makes Rhino particularly popular in industries that require precise and complex modeling, such as architecture, engineering, and product design.

In addition to its core modeling capabilities, Rhino offers a range of advanced features.

The 'ShrinkWrap' feature allows users to create a watertight mesh around any geometry, which is particularly useful for preparing models for 3D printing. The 'SubD Creases' feature enables the creation of fillet-like features, providing additional control over the shape and smoothness of the model.

One of the standout features of Rhino is 'Grasshopper', a visual programming environment that is tightly integrated with Rhino's 3D modeling tools. Grasshopper requires no knowledge of programming or scripting, but still allows designers to build generative forms. This makes it possible to create complex, parametric designs that can be easily adjusted and optimized.

Design Accomplished Using Rhino 3D V7.

1. Detail Design of Ship

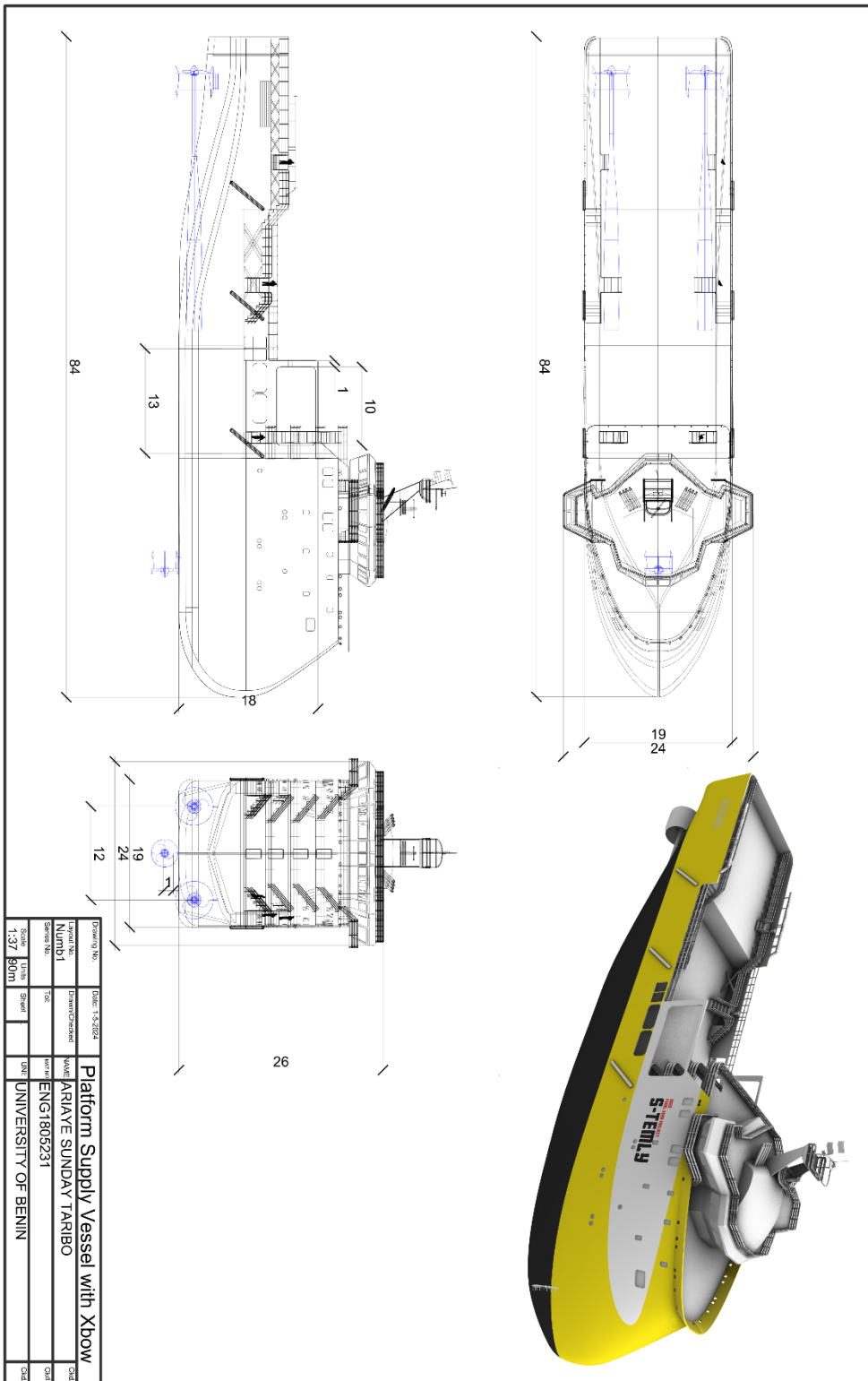

2.4 PREVIOUS WORKS

This study tackles a real-world issue in the oil industry concerning the delivery of general cargo to offshore rigs and production units. The objective is to find the best two-dimensional arrangement of deck cargoes on a supply vessel assigned a specific route, with the aim of maximizing overall profit while adhering to various safety and operational guidelines. Mathematically, this problem can be considered a complex variant of the two-dimensional knapsack problem, as some cargoes might be deferred to a subsequent trip. The complexity increases further considering that the trip could serve multiple offshore units and a significant number of items are expected to be returned from these units, transforming the problem into a pickup and delivery allocation issue. To address this, we suggest a probabilistic constructive method coupled with a local search heuristic. We also present the outcomes of computational tests with randomly created instances. These findings demonstrate that our suggested heuristic can effectively assist ship planners in managing such large-scale allocation problems that come with numerous operational restrictions.

Ship bow forms have a significant effect on the ship resistance components, especially wave making resistance component and throughout the years, ship hydrodynamic researchers invent different forms to minimize ship resistance. This study illustrates conventional bow form, bulbous bow form and shows the popular method to design the bulb for given hull and some of innovative bow forms and focused on X-bow form type beside that explain how to design hull to be suit with x-bow depending on the reverse engineering technique. Ship resistance components are shown with method of estimation by different experimental, empirical and numerical method beside that study the effect of some parameters on resistance components and recommended the optimum range of each parameter. The three reference hulls are chosen to perform test cases and evaluate the innovative Xbow form are series 60 of cargo model hull,

KCS for container model hull and DTMB 5415 for navy combatant model hull. Geometrical 3d modeling of three reference hulls are created by using Rhinoceros 3d software beside that three reference hulls are modified to be with X-bow and addition to that delta bulb type is added to series 60 hull model. Experimental data of three reference hulls are collected to use for validation with numerical code of CFD-Fluent results. The numerical setup stages are illustrated to estimated resistance components of viscous resistance and wave making resistance. During this stages, the mesh independency study of series 60 hull model are created due to lack information about the optimum mesh number for numerical estimation but the number of mesh for KCS model and DTMB 5415 are obtained from previous numerical studies. The comparison between the reference hull models and modified models are needed to show the amount of reduction in wave a making resistance due to fitting X-bow. The data obtained from this study is used in the create of equivalent wave making resistance reduction equation due to using x-bow for given hull instead of using bulbous bow and beside that is identified the limitation of this equation.

Air pollution is a major concern in the maritime industry because of its negative health impacts and greenhouse gas emission. Reducing the friction and resistance on the hull of a marine vessel improves the efficiency. It also reduces fuel consumption and carbon emissions in the atmosphere. Researches show that the design of the forward part of the hull has an effect on the total hull resistance. This paper explains how to reduce air pollution from an X-bow ship by analyzing the ship's bow and making essential modifications. The analysis of the front section of an X-bow ship demonstrated how the flare angle and stem angle have an effect on the total hull resistance. The model of the ship was created by using the Rhinoceros software, and the CFD analysis was done in Autodesk CFD software. Based on the results, it was found that the X-bow model of (10° stem, 10° flare) has optimal ship performance between the range speed of 8-14 knots as compared with the original X-bow ship of (6° stem, 21° flare). The new

model (10° stem, 10° flare) requires an Effective Horse Power (EHP) of 2847.97 HP, which is much lower than the power of the original model, 3947.56HP.

CHAPTER THREE

MATERIALS AND METHODS

3.1 MATERIALS

The materials used in this project are classified below based on

- a. Structure
- b. Electronics
- c. Software

Structure

The structural materials used include

- i. Fiber glass
- ii. Shaft with Propeller blades
- iii. Resin

Electronics

- i. Electric motors (Brushed Direct current motors).
- ii. Electronic speed controllers
- iii. Sensors
- iv. Connectors
- v. Servo
- vi. Radio system transmitter
- vii. 11.1v lipo battery charger

3.2 Structure

The structure of the prototype platform supply vessel (PSV) includes the body and frame, and propellers. The former is the static structure while the propeller is a dynamic structure. The PSV frame was made from fiber mat.

Fiberglass

Fiberglass is a lightweight, strong, and versatile material made from fine fibers of glass. It is commonly used in a wide range of applications, including insulation, construction, automotive, aerospace, and marine industries. Fiberglass offers several advantages, such as high strength-to-weight ratio, resistance to corrosion and chemicals, excellent electrical insulation, and thermal

insulation properties. It is also known for its durability and ability to be molded into various shapes.

Fiberglass is widely available and can be found in many stores that sell construction and building materials. It is also available online from various retailers. The availability may depend on the specific location and region, but generally, fiberglass is easy to find and purchase. In addition to the fiberglass material itself, other products related to fiberglass, such as resins, adhesives, and tools, are also available for purchase.

In summary, the use of fiberglass in fabrication is important due to its strength and durability, lightweight nature, resistance to corrosion and chemicals, design flexibility, insulation properties, and cost-effectiveness. These benefits make fiberglass a popular choice across various industries for producing high-performance parts and components.

The above reasons clearly state why we decided to use fiberglass for our prototype platform supply vessel (PSV).

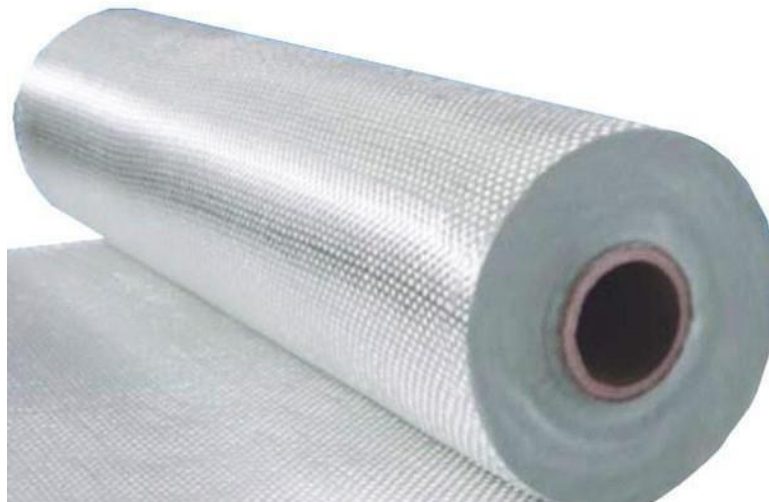

Fig 3.1: Fiberglass

Shaft with Propeller blades

A shaft with propeller blades is a common component used in various applications involving fluid dynamics, particularly in marine and aerospace industries. The shaft serves as a

mechanical linkage connecting the power source, such as an engine or motor in this case, to the propeller blades. It efficiently transmits rotational motion from the power source to the blades, converting the rotating force into thrust or propulsion.

The propeller blades, on the other hand, are specifically designed to generate lift or forward motion by creating a pressure difference between the front and back surfaces of the blades. As the blades rotate, they create a flow of fluid and generate a force called thrust.

The propellers were chosen based on our design specification, cost and the durability of the part. The propeller used in this project is 40mm diameter.



Fig 3.2 Plastic propeller with 30cm shaft.

Resin

Resin is a viscous, often transparent substance that hardens through a chemical reaction typically with a catalyst or hardener. It is commonly used in various applications, including fabrication, coatings, adhesives and composites.

Resin plays a vital role in fabrication due to its bonding ability, moldability, strength, durability, chemical resistance, aesthetic enhancement and customizable properties. It is a versatile

material that enables the creation of high-performance and visually appealing fabricated products.



Fig 3.3 Resin

3.3 Electronics

The components listed here are electrical components. They include components that stores electrical energy, transports and uses electrical energy, and process electronic signals.

Electric motors (Brushless Direct current motors)

Brushless motors (BLDC) are electric motors that operate without brushes, resulting in higher efficiency, longer lifespan, reduced electromagnetic interference, and quieter operation compared to brushed motors. They offer higher torque-to-weight ratios and precise speed control. The qualities of a brushless motor make it useful in various ways that include propulsion of drone systems, unmanned aerial vehicles, industrial automation, medical devices, Aerospace & aviation and so much more.

Brushless motors use the electromagnetic induction concept to provide rotational motion.

Brushless motors use electronic commutation via a controller, in contrast to conventional brushed motors, which use brushes and a commutator to alter the direction of current flow in the coils.

In this project, we used an A2212 brushless DC motor. The first two digits, “22,” in millimeters, indicate the motor’s stator diameter. The following two digits, “12,” stand for the stator height or length of the motor in millimeters.

The “KV” in “1400KV” stands for “Kilovolt.” This phrase refers to an electrical characteristic of the motor, specifically the voltage-to-rotational-speed ratio. KV stands for the number of revolutions per minute (RPM) the motor will make at a voltage of one volt. Therefore, when powered by 1 volt, a 1400KV motor will spin at roughly 1400 RPM.

Ensuring compatibility between the motor and battery voltage is essential to achieve the desired RPM and performance.



Fig 3.4: An 'A2212' 1400Kv/10T Brushless DC motor.

Electronic speed controllers ESCs

Electronic speed controllers (ESCs) are devices used to control the speed and direction of electric motors.

They receive signals from a control system (such as a remote control) and adjust the power supplied to the motor accordingly. ESCs are commonly used in RC vehicles, drones, and other motorized systems where precise speed control is required, in which our prototype platform supply vessel is not an exemption.



Fig 3.5: A 40A ESC

Connectors

Connectors play a crucial role in establishing electrical connections between different components. They facilitate the transfer of power, signals, and data between devices. Connectors come in various types and form factors, ranging from simple two-pin connectors to complex multi-pin connectors used in aerospace and automotive applications.

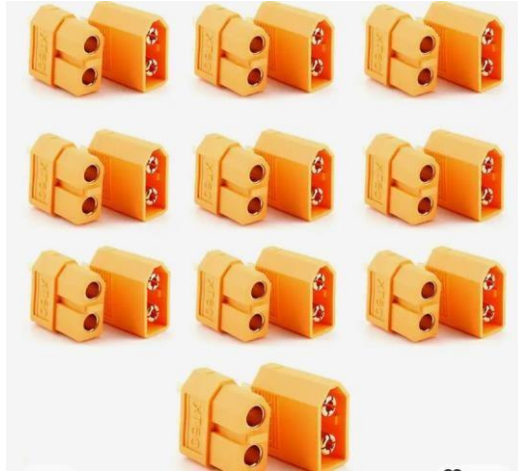

Fig 3.6: XT60 male/female bullet Connectors

Servo

Servos are devices that convert electrical signals into precise mechanical motion. They typically consist of a motor, a position feedback device (such as a potentiometer), and a control circuit. Servos are widely used in robotics, RC vehicles, and automation systems to control the position, speed, and torque of mechanisms. They offer high precision and accuracy, making them suitable for applications that require precise control, such as robotic arms, steering systems, and camera gimbals. We use the servo in this system to serve as our rudder for directional motion.



Fig 3.7: Servo

Radio system transmitter

A radio system transmitter is a device used to transmit control signals wirelessly between a remote controller and a receiver. It typically operates on radio frequencies and enables remote control and communication with devices such as RC vehicles, drones, and wireless audio

systems. The transmitter converts the user's input into radio waves, which are then received and interpreted by the receiver, allowing for remote operation and control.



Fig 3.8: 2.4Ghz 4CH Radio Transmitter

11.1v LiPo battery balance charger

An 11.1v LiPo battery charger is a specialized charger designed for charging lithium polymer (LiPo) batteries with a normal voltage of 11.1v. LiPo batteries are commonly used in various portable electronic devices, RC vehicles, and drones. The charger ensures safe and efficient charging by monitoring and controlling the charging process, preventing overcharging or overheating that could potentially damage the battery. It typically provides features such as adjustable charging rates, charge level indicators, and safety mechanisms to ensure proper battery management.



Fig 3.9: 11.1v Li-polymer Battery charger.

3S Lithium-ion battery

According to the specifications of the ESC we used, the compatible battery is three cell (3S) lithium polymer battery. The battery is the powerhouse of the prototype platform supply vessel, it stores energy chemically and releases when needed through chemical reactions in electrical form for use.

3.4 Software

1. Rhinoceros 3D

The software platform known as Rhinoceros, commonly known as Rhino, is a popular 3D modeling software developed by Robert McNeel & Associates. It is widely used in various fields like product design, architecture, industrial design, and visual effects. Rhino offers a range of powerful tools and features that enable efficient and accurate 3D modeling and design.

Some of the key features of Rhino are:

- I. **NURBS (Non-Uniform Rational B-Spline) geometry:** Rhino's NURBS-based

geometry allows for accurate and flexible modeling of complex shapes and curves. It provides tools for creating, editing, and analyzing NURBS curves and surfaces, allowing for precise control of dimensions and design parameters.

- II. ***Plug-in support:*** Rhino supports a range of plug-ins, including rendering engines, analysis tools, and material libraries. This allows users to extend the functionality of the software and customize their workflow according to their needs.
- III. ***Grasshopper:*** Rhino's visual programming language, Grasshopper, allows for the creation of complex scripts that automate repetitive tasks and simplify workflows. It provides a user-friendly interface for building parametric models and provides access to a range of algorithms and data structures.
- IV. ***Import/export support:*** Rhino supports a wide range of file formats for importing and exporting 3D models, including DWG, DXF, OBJ, STEP, and STL. This enables seamless collaboration with other software and platforms.
- V. ***Layout and annotation tools:*** Rhino provide tools for creating 2D drawings and technical documentation, including dimensions, annotations, and hatches. This allows for easy communication of design intent and specifications.
- VI. ***Compatibility:*** Rhino is compatible with both Windows and Mac operating systems, making it accessible to a wide range of users.
- VII. ***3D modeling tools:*** Rhino offers a comprehensive set of 3D modeling tools that allow users to create, edit, and manipulate complex 3D geometry. This includes tools for extruding, lofting, sweeping, and blending surfaces, as well as Boolean operations for combining or subtracting geometry.
- VIII. ***Visualization and rendering:*** Rhino provide built-in rendering capabilities, allowing users to visualize their models in realistic materials, lighting, and environments. It also supports third-party rendering plugins, providing even more advanced rendering options and effects.

- IX. ***Analysis tools:*** Rhino includes various analysis tools that help users evaluate and optimize their designs. This includes tools for measuring distances, angles, and areas, as well as tools for calculating curvature, draft angles, and mass properties.
- X. ***Animation and visualization:*** Rhino support animation and visualization features, allowing users to create dynamic presentations and walkthroughs of their models. It also supports virtual reality (VR) technologies, enabling immersive experiences and real-time interaction with 3D scenes.
- XI. ***Parametric modeling:*** Rhino supports parametric modeling, allowing users to define and control design parameters and relationships. This makes it easier to make iterative changes to the design and update the geometry based on varying inputs.\
- XII. ***Advanced scripting and customization:*** Rhino provide scripting capabilities through languages like Python and RhinoScript, enabling users to automate tasks, create custom workflows, and extend the software's functionality. This allows for increased efficiency and customization tailored to specific project requirements.
- XIII. ***Multi-disciplinary compatibility:*** Rhino's versatility enables easy collaboration and compatibility with other software and workflows used in various industries. It supports integration with software like AutoCAD, Revit, SketchUp, and more, facilitating seamless data exchange and interoperability.

Design Accomplished using Rhino

1. Detail design of ship

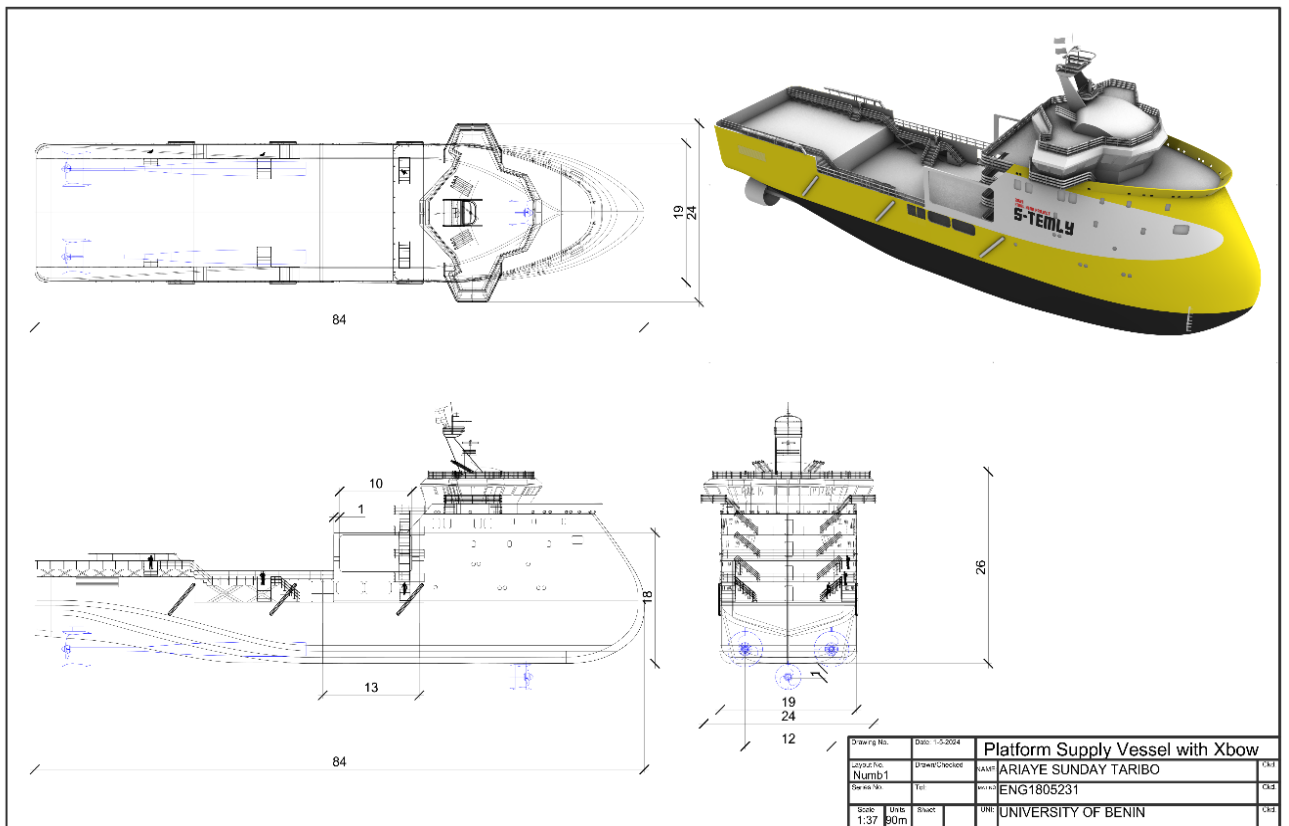

2. Offset Table of Ship Hull

3. Render and Animation of 3D design

2. Maxsurf

Design Accomplished using Rhino

1. Stability Analysis of ship hull
2. Hydrostatic of ship hull
3. Resistance Analysis
4. Criteria Analysis of hull and vessel type

3.5 Functional requirements

The ROV is required to carry out the task of underwater inspection of sea chest at a depth not exceeding 5m. The functional requirements for the design of the ROV are highlighted in the table below

Serial	Functional Requirements	Reason	Description
1	X-bow hull form	Is the title of our project and the main task	This distinctive form is characterized by a sleek, angular profile with a pronounced forward slope that extends downward and outward from the vessel's waterline. The bow typically lacks a sharp point, instead featuring a rounded or blunted leading edge.
2	Mobility	Defines how the PSV is able to maneuver	It should move forward/backward and turn left/right.
3	Demonstration of Principles	This can help students understand real-world applications of Marine Vessel principles of operation.	The model boat should be able to demonstrate fundamental principles of physics and engineering, such as buoyancy, stability, and propulsion.
4	Distance	Range of operation and proximity from remote control.	Since PSV is surface vehicle, it will operate at comparatively shallow water (0.4m). Innate buoyancy makes this possible.

5	Buoyancy & stability	Hull form	Innate buoyancy as per Archimedes' principle.
6	Control	The type of control to be used by the controller	It will be manually remote controlled. No automation systems
7	Propulsion	Enables the motion of the vessel	Prime mover is Electric motor.
8	Steering Mechanism	We included a dual rudder system.	Enables directional changes.
9	Power source	Appropriate power source used for our electrical components.	
10	Scale representation	Model is a scaled down representation of a real PSV. Including xbow hull shape and Superstructure.	
11	Lighting	Includes basic lighting that replicates lights on a real vessel	

3.6 Methodology

This drone was designed using some locally sourced materials for efficiency in deep-sea research and exploration. The method of conceptual design was used.

Concepts

During the trajectory of this project, several unique bow designs were considered

Concept one: PSV with bulbous bow

The bulbous bow as the name suggests has a bulb profile that extends below the waterline from the bow of a ship. The most common type of bow is found on cargo vessels and other displacement vessels that are designed to carry a heavy load.

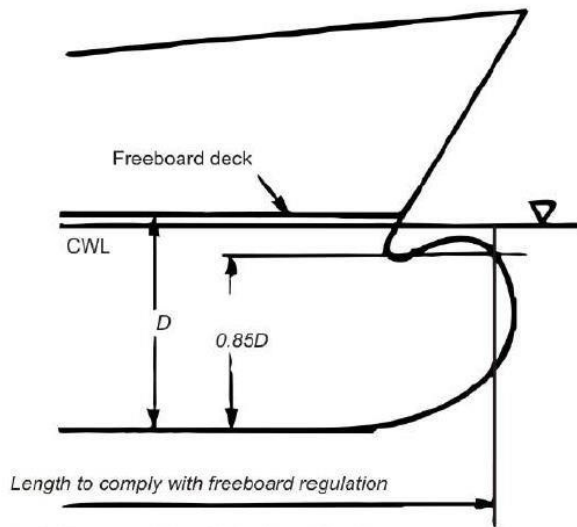

Fig.8 Length of freeboard calculation with low freeboard deck

Concept 2: PSV with inverted bow

An inverted bow, also known as a reverse bow, is a distinctive ship design where the bow's furthest point is near the waterline rather than at the top. This configuration, reminiscent of a submarine's bow, offers benefits such as increased hydrodynamic efficiency and extended waterline length, which can improve hull speed and fuel efficiency. However, it also has drawbacks like reduced reserve buoyancy, potentially causing the ship to dive under waves.



Fig: I; Zumwalt class destroyer with inverted bow



ii; Recreational Yacht with inverted bow

Concept 3: PSV with XBOW™

The X-Bow is a pioneering bow design developed by Ulstein Group for offshore and expedition vessels, characterized by its inverted shape that slopes downward and inward towards the waterline, forming an 'X' profile. This unique design improves seakeeping by reducing slamming and wave impact, enhances fuel efficiency by minimizing resistance, and increases safety by mitigating green water on deck and improving stability in rough seas. The X-Bow's innovative construction methods allow for its integration into various vessel types, making it a versatile and recognized solution in modern ship design.



Fig: X-BOW typical sideprofile

3.7 Design matrix

In this project, we have adopted a methodology centered on a choice matrix rather than a conventional design matrix. The distinction lies in our focus on evaluating and selecting from existing options rather than designing entirely new solutions. Our approach involved navigating a landscape of pre-existing choices rather than creating novel designs from scratch.

Of the three proposed bow concepts, only one can be used for the prototype. We based our decision matrix on three major criteria that we considered most important for whatever design we choose. The criteria are:

a) Cost

b) Efficiency

c) Aesthetics

a. Cost

Given that the material requirements for constructing different bow shapes remained largely consistent, cost considerations were not a decisive factor in selecting the preferred bow design.

b. Efficiency

The XBOW hull design offers significant efficiency advantages over traditional inverted and bulbous bows. Its innovative shape allows for smoother wave penetration, reducing the bow impact and minimizing slamming, which in turn leads to a more stable and comfortable voyage. The XBOW's pointed, rounded front increases buoyancy at the fore, enabling the vessel to maintain higher speeds in rough seas without the need for increased engine power. This unique design also results in less spray and noise, contributing to a quieter and drier deck environment. Moreover, the XBOW hull's superior hydrodynamics enhance fuel consumption, allowing for a more efficient power-speed relationship, which is crucial for long voyages. In contrast, the bulbous bow, while increasing buoyancy and stability, does not provide the same level of wave energy distribution or reduction in slamming, making the XBOW a more advanced and efficient option in challenging sea conditions.

c. Aesthetics

The XBOW is often considered more aesthetically appealing than the inverted or bulbous bows due to its distinctive and modern design. Its sleek, rounded but pointed shape represents a break from traditional ship designs, which tend to have a more utilitarian appearance. The XBOW's design is not only functional but also visually striking, giving vessels a futuristic and cutting-edge look that can be seen as a symbol of innovation and progress in marine engineering. Additionally, the absence of a bulb at the bow and the continuous sharp bow shape contribute to a cleaner and more streamlined profile, which is often associated with speed and efficiency. This combination of form and function resonates with contemporary design sensibilities, where aesthetics are increasingly valued alongside performance.

3.8 Detailed design Process:

1. Using Images as reference we were able to design our ship Hull to Desired Concept.
Below are the reference Image:

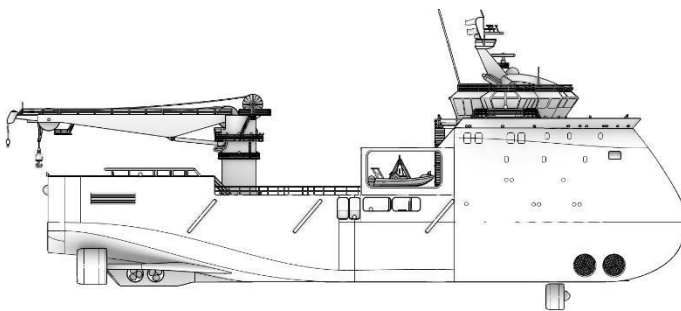

Fig 3.8.1 Side view

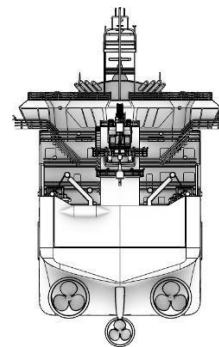

Fig 3.8.2 Rear view

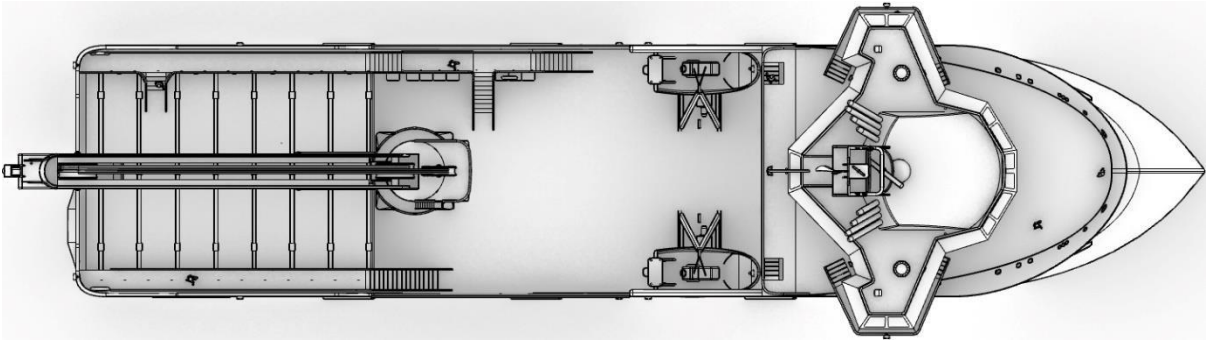

Fig 3.8.3 Top view

2. 3D Design Modeling Using Reference on Rhino

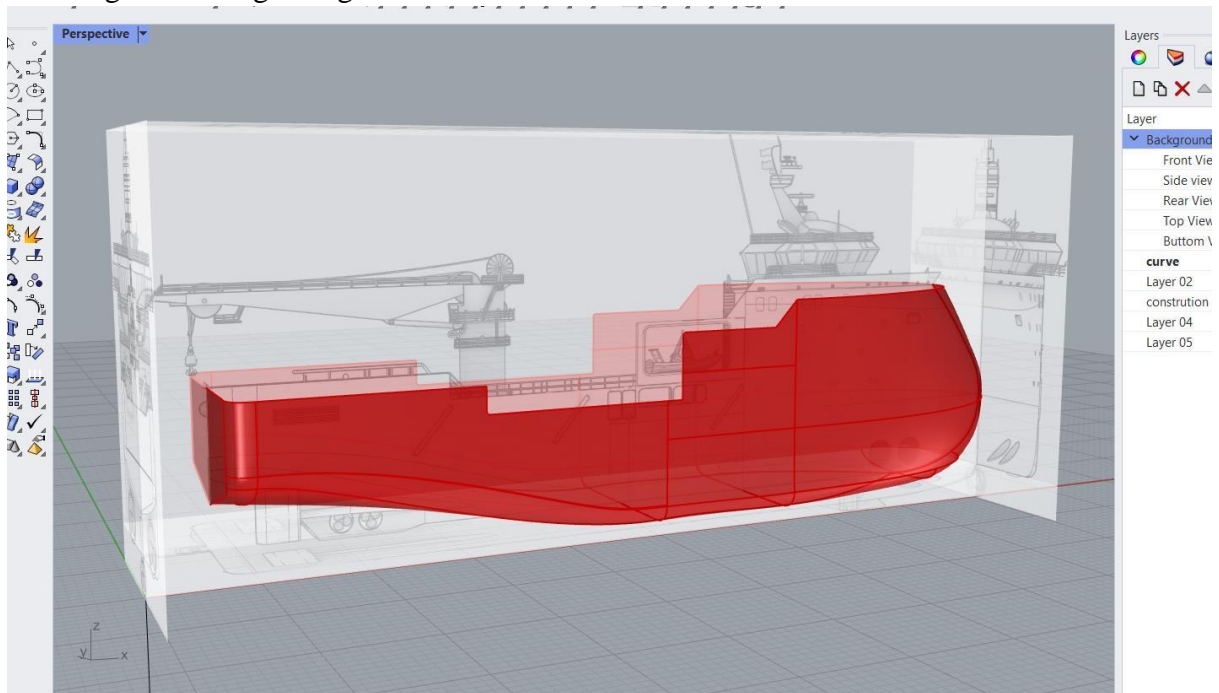

Fig 3.8.4 Screenshot of Software Rhino V7 while carrying out modeling using reference

3. After Carrying out 3D modeling of our Hull To a desirable length we ran Analysis on the Hull form so as to make the hull form Favorable. The analysis was carried on other Marine Software Like Delfmarine Where we were able to get my Offset Table and then on Maxsurf to get Stability, Hydrostatic and Resistance of the hull.

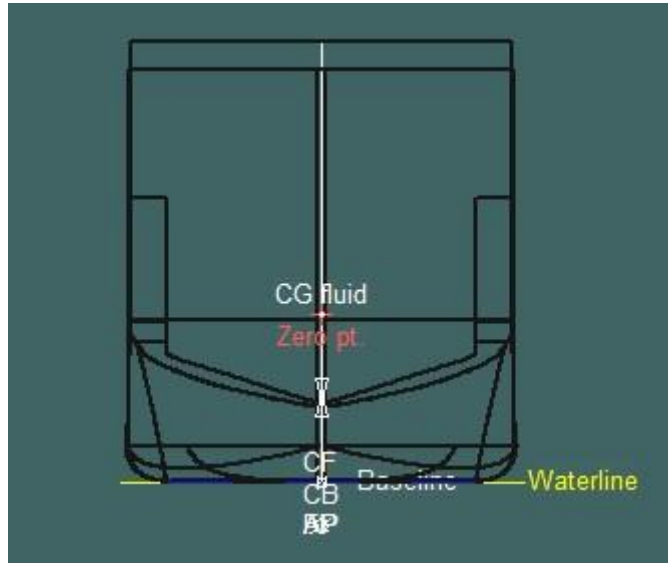

Fig 3.8.5 Screenshot Taken On maxsurf while carrying analysis.

4. After Getting the favorable Hull Form Next in line was to continue our 3D Modeling Process of the complete ship, with that we were able to produce our full 3D Render Design of our Prototype.



Fig 3.8.5 3D Rendered image of our prototype using Maxsurf

5. Next in line was to produce a Technical Drawing of our ship Using Rhino

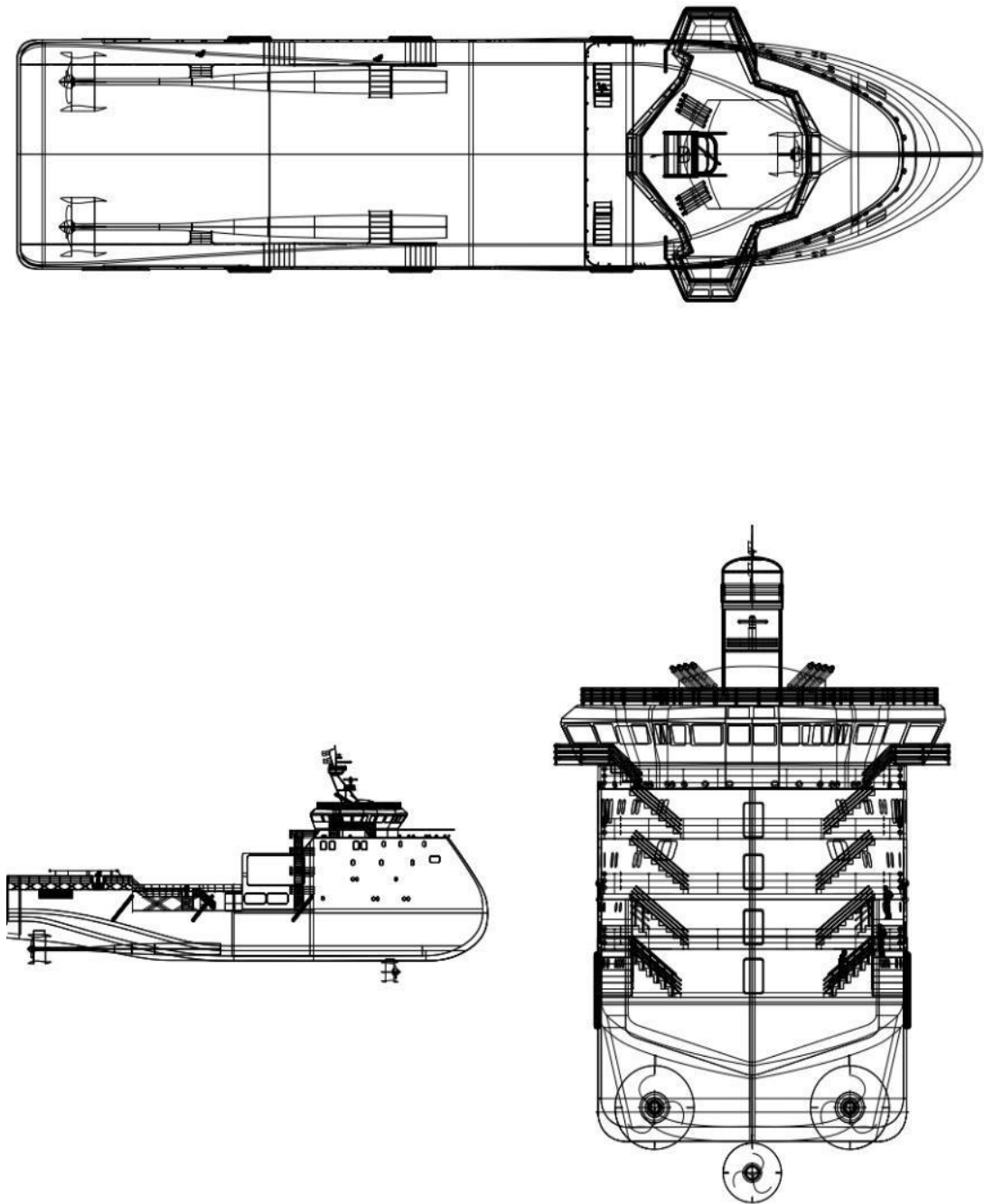

Fig 3.8.6 A paper sheet image of prototype design using Rhino

6. With the paper sheet we were able to draft the dimension of our ship using a favorable scale

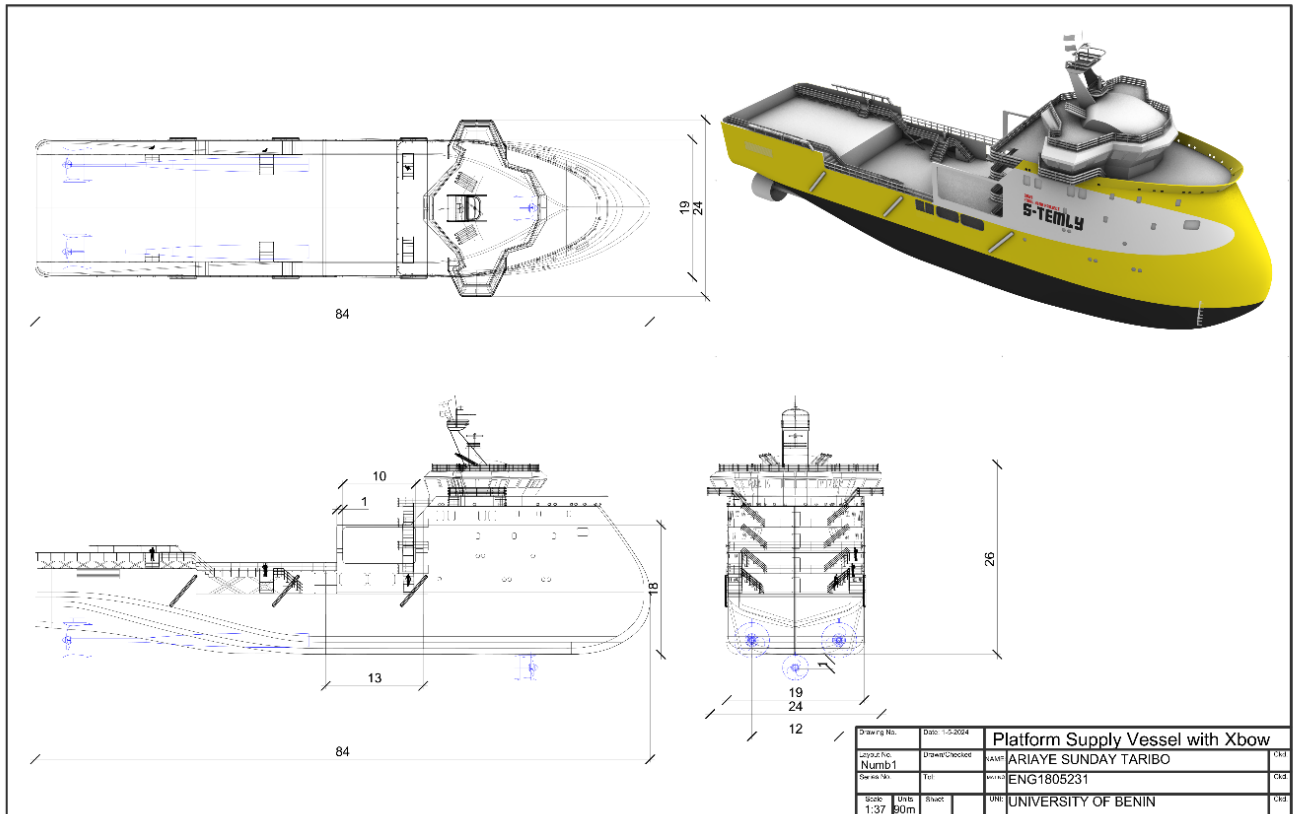

Fig 3.8.7 Draft Image of Prototype Gotten using Rhino

PROCEDURE FOR FABRICATION

After getting all the required materials, below, our processes of fabrication .

1



**Getting
Mold of Ship Hull using
Clay**

2

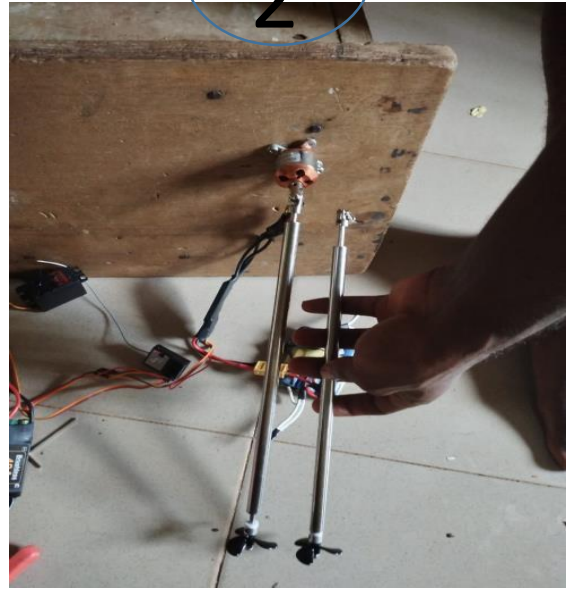

**Electrical Assembly and
Calibration**

3



**Getting the hull of ship from
mold using Resin Catalyst and
Fiber Mat**

4



Ship Part Assembled

5



Welding Of hand rails and rudder.

6



Refining and sand blasting

7

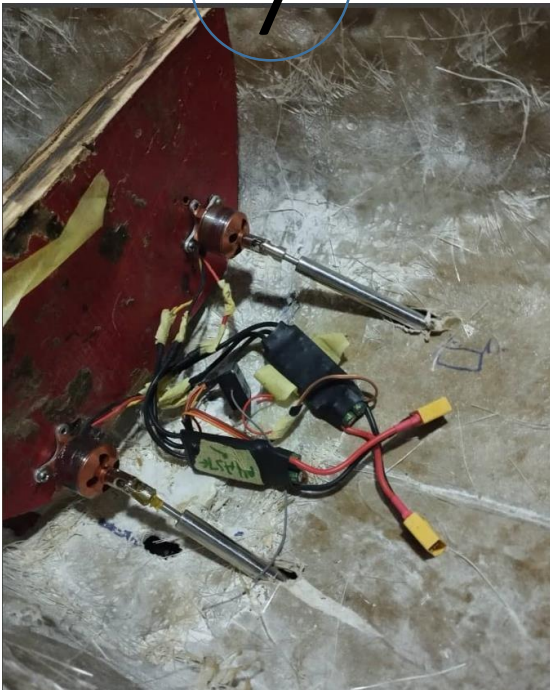

Installation of hand rails, propeller, rudder and other Electrical parts on ship hull.

8



Painting of ship.

3.9 Bill of engineering materials and evaluation (BEME)

Table 3.5: BEME

S/N	Component	Specifications	Quantity	Unit cost (₦)	Total cost (₦)
1	Motor	Brushless motor A2212 10T	2	12,000	24000
2	Boat Shaft with Propeller	Length 30cm boat shaft with 4cm diameter propeller	2	14,010	28,020
3	Digital Servo	High torque MG996R 4.8-6.0V Digital Servo with metal gear	1	5070	5070
5	Brushless speed controller	Brushless 40A ESC speed controller.	2	7755	15510
6		7.4v 11.1v Balance Charger 2s 3s cells	1	7335	7335

	Li-polymer battery charger				
7	POP	Plaster of Paris	1 bag	10,000	10,000
8	Resin	Adhesive & agglutinate for Fiber mat	6 Liters	5500	33,000
9	Fiber Mat		1&1/2 yard	3,500	5,000
10	Catalyst		10 cl	16,000	1,600
11	Accelerator		10 cl	16,000	1,600
12	Brush		5	300	1500
13	Rod		1/4	600	600
14	Sandpaper	Abrasive paper		1,100	1,100
15	Paint	Black, Yellow & White Paint	1 liter	5500	5500
16	Body Filler			3000	3000
17	Thinner	Paint thinner	35cl	1200 bottle	1200
18	Lacquer	Coating			5000

19	Glue	Adhesive	50cl		4000
----	------	----------	------	--	------

Table 3.6: Total cost of PSV

Serial	Description	Amount(₦)
1.	Materials	123,335
2.	Miscellaneous expenses	80,000
3.	Total	203,335

CHAPTER FOUR

RESULTS AND DISCUSSION

4.1 OFFSET TABLE RESULT

The First Overall result got from the project is that of our Hull Form Offset Table, after the desire Hull Form was gotten using the Rhino 3D I was able to get Offset table

HYDROSTATICS CALCULATION:

By having the faired offset of 10 waterline of equal spacing, we found Hydrostatics characteristics for each Waterline and drawn the Hydrostatics curves after Running our CAD file in Maxsurf Stability

Here's Our Result

Hydrostatics – Platform Supply Vessel x-bow model

Stability 23.04.00.76, build: 76

Model file: C:\Users\THE GEARABLES\Downloads\Taribo model (Medium precision, 66 sections, Trimming off, Skin thickness not applied). Long. datum: MS; Vert. datum: DWL.

Analysis tolerance - ideal(worst case): Disp. %: 0.01000(0.100); Trim%(LCG-TCG): 0.01000(0.100); Heel%(LCG-TCG): 0.01000(0.100)

Damage Case - Intact

Fixed Trim = 0 m (+ve by stern)

Specific gravity = 1.025; (Density = 1.025 tonne/m³)

Draft Amidships m	8.327
Displacement t	9216
Heel deg	0.0
Draft at FP m	8.327
Draft at AP m	8.327
Draft at LCF m	8.327
Trim (+ve by stern) m	0.000
WL Length m	84.612
Beam max extents on WL m	19.144
Wetted Area m ²	2439.932
Waterpl. Area m ²	1361.417

Prismatic coeff. (Cp)	0.672
Block coeff. (Cb)	0.667
Draft Amidships m	8.327
Max Sect. area coeff. (Cm)	1.004
Waterpl. area coeff. (Cwp)	0.840
LCB from zero pt. (+ve fwd) m	-1.566
LCF from zero pt. (+ve fwd) m	-5.375
KB m	4.808
KG m	8.327
BMt m	4.298
BML m	79.229
GMt m	0.779
GML m	75.710
KMt m	9.106
KML m	84.037
Immersion (TPc) tonne/cm	13.955
MTc tonne.m	83.562
RM at 1 deg = GMt.Disp.sin(1) tonne.m	125.292
Max deck inclination deg	0.0000
Trim angle (+ve by stern) deg	0.0000

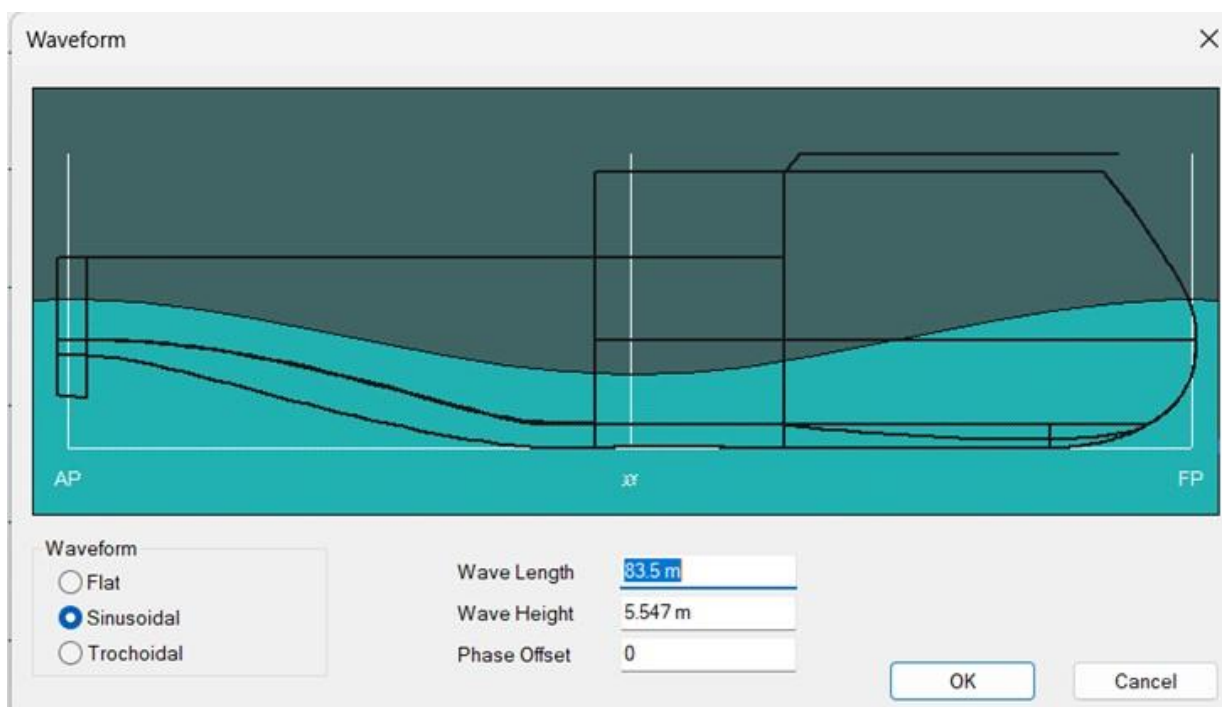
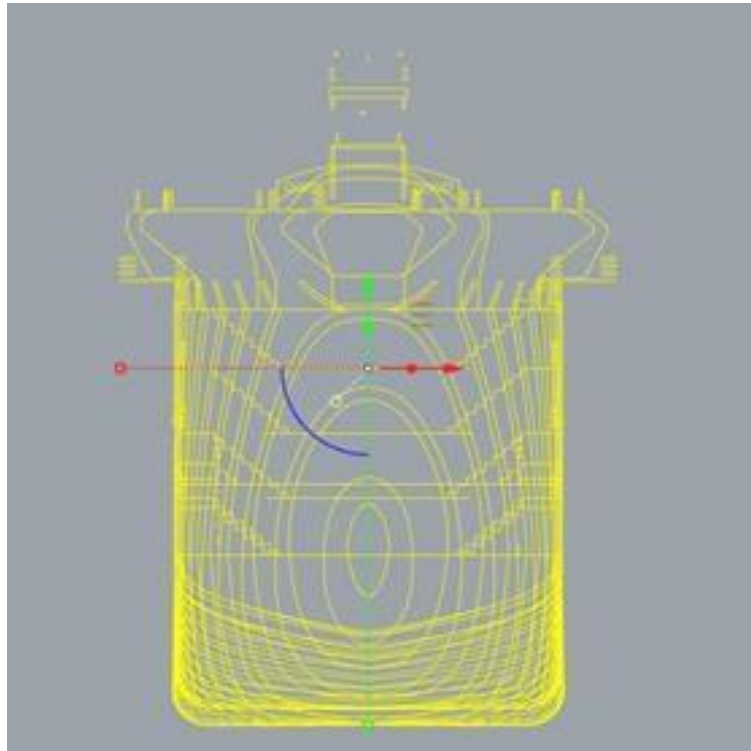

With the help of our CAD design we Ran analysis for **Hydrostatic** , **Stability** and **Resistance** Using a specialized Marine Software **Maxsurf**.

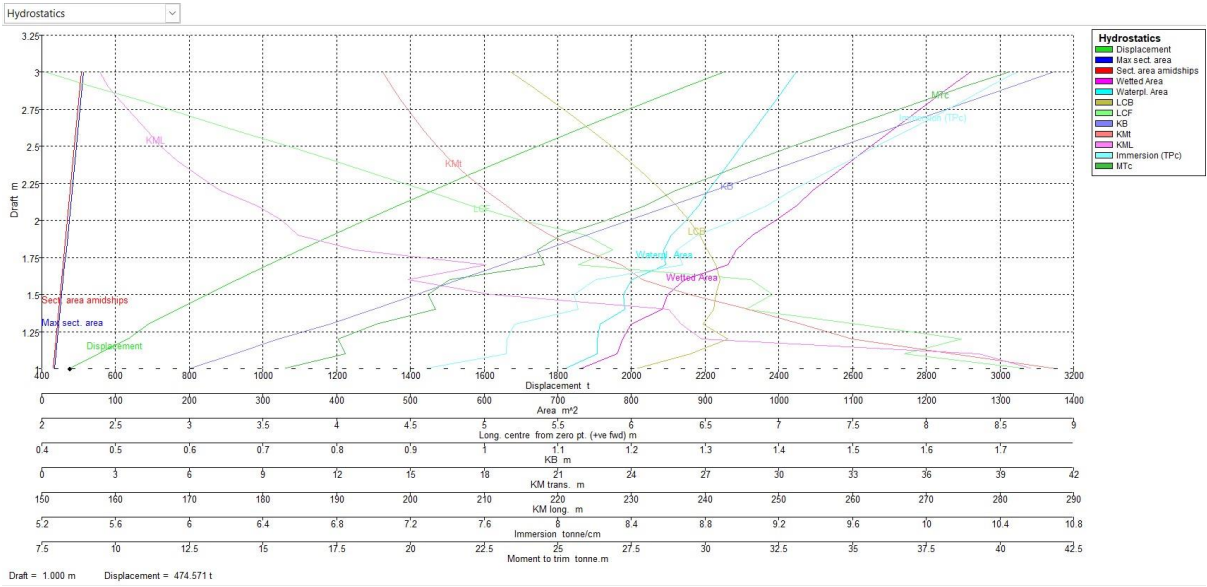

Graph of Hydrostatics

CHAPTER FIVE

CONCLUSION AND RECOMMENDATION

5.1 Conclusion

We have developed a prototype Platform Supply Vessel (PSV) with a unique X-BOW hull design. This design improves floatation, stability, and buoyancy, making the PSV excellent at handling rough seas. It's also visually striking, setting a new standard in maritime design.

Our PSV has a high-quality motor and propeller system for reliable movement in various sea conditions. We used fiberglass in the construction to increase durability and reduce weight, which is key for fuel efficiency and performance.

One of our biggest achievements was installing the rudder. Aligning it with the X-BOW design was complex, but we managed it, showing our team's dedication and skill.

This project is the first step towards future advancements in PSV technology. As we move from prototype to practical application, we will continue refining and improving, keeping our PSV at the cutting edge of offshore supply solutions.

Despite setbacks encountered during testing and construction, Our PSV project shows the potential of the X-BOW design to transform maritime capabilities. It is a blend of innovation, sustainability, and operational excellence, and we are proud to be shaping the future of offshore transportation.

5.2 Recommendation

The PSV is also an educational tool, helping students and maritime enthusiasts learn about ship design and its impact on maritime operations.

We have tackled industry challenges like optimizing cargo storage, improving fuel efficiency with advanced propulsion systems, and promoting sustainability with reduced emissions and eco-friendly materials.

REFERENCES

- Aas, B., Gribkovskaia, I., Halskau Sr, Ø. and Shlopak, A., 2007. Routing of supply vessels to petroleum installations. *International Journal of Physical Distribution & Logistics Management*, 37(2), pp.164-179.
- Electroniceforu.com
- Hamisi, T.S., Ali, F.M., Mohammed, T.I. and Gathua, C., 2023. Analysis of the ship's bow to minimize air pollution—case study of the X-bow ship. *Journal of International Maritime Safety, Environmental Affairs, and Shipping*, 7(4), p.2276989.
- LAYNE JR, PASSION KM. Fuzzy model reference learning control for cargo ship steering {J}. *IEE Control system*, 1993, 13(6): 457-462.
- Marineinsight.com/naval-architecture
- Mastering RC Boat Remote Control: Tips, Types, and Components (swellrc.com)
- Mosaad, M.A., Gafaary, M.M., Yehia, W. and Hassan, H.M., 2017. On the design of X bow for ship energy efficiency. *Influence of EEDI on Ship Designu0026amp; Operation*, London, UK, 22.
- Preliminary estimation of the Principal dimensions of offshore supply vessel BASED on
 - updated statistics. (MOHAMED WALID AHMED, AHMED NAGUIB, ELSAYED H. HEGZY)
- Swellrc.com/rc-boat-remote-control
- Ulstein.com/innovations/x-bow-marineinsight.com/naval-architecture
- <https://fastercapital.com/content/Offshore-oil-extraction--FPSOs--Advancements-in-Offshore-Oil-Extraction.html>
- <https://www.coursehero.com/file/236895117/9docx/>
- https://wiki.osarch.org/index.php?title=Rhinoceros_3D
- <https://www.travelbyships.com/cruise/bottom-of-a-cruise-ship/>