

DESIGN AND CONSTRUCTION OF SECURITY ALARM SYSTEM DETECTOR

BY

David Enwuoro ISIAKA

LSC1810740

**A PROJECT SUBMITTED TO THE DEPARTMENT OF SCIENCE LABORATORY
TECHNOLOGY, FACULTY OF LIFE SCIENCES**

**IN PARTIAL FULFILMENT FOR THE AWARD OF BACHELOR OF SCIENCE, B.Sc.
(HONS) SCIENCE LABORATORY TECHNOLOGY OF THE UNIVERSITY OF BENIN,
BENIN CITY.**

MAY, 2024

CERTIFICATION

We the undersigned hereby certify that David Enwuoro ISIAKA with matriculation number LSC1810740 carried out this work titled ‘design and construct a security and alarm system with sound and motion detector.’ in the Department of Science Laboratory Technology, Faculty of Life Sciences, University of Benin, Benin City And we approve same as adequate in the scope and quality for the award of Bachelor of Science Degree (B.Sc.) in the Science Laboratory Technology.

Engr. K. O. OJO
(Project Supervisor)

Date

Mrs. P.O OMOZUWA
(Project Coordinator)

Date

Prof. E.O. OSHOMOH
(Head of Department)

Date

(External Examiner)

Date

DEDICATION

I dedicate this project work to God Almighty who has been my source of inspiration and strength, who in his infinite mercies have seen me through this work.

ACKNOWLEDGEMENTS

I want to give thanks to God almighty for his love and protection. He is the giver of life and all good things and He alone made this project research a fulfillment. I am truly grateful for His guidance, support, inspiration, and strength throughout this work. He is a light unto my path.

My sincere appreciation goes to my supervisor Engr. Ojo Kennedy for his unwavering support and invaluable contributions throughout this journey. Also, my appreciation to the Head of Department, Prof. E.O. Oshomoh. And to my course adviser, Mr. Archibong whose counsels, encouragement, and guidance contributed to the success of this study. Also, my appreciation goes to the project coordinator, Mrs. P.O Omozuwa and the entire lecturers in the department.

My special thanks go to my sweet mother Mrs Yekini Josephine, for her love, prayers, and constant support that has brought me this far in my academic journey. And to my dad Isiaka Abdul Yekini, to my elder brother Isiaka Okasime Emmanuel and Olorunfemi Wisdom Obale and to my wonderful friends, Mercury Wealth Warikwah and Uwugiaren Blessed and other persons not mentioned, thank you so much for your prayers, love, words of encouragement, and support. Finally, to my humble self, for being steadfast and resilient even through the challenges faced in this educational pursuit, you are strong boy and you stand firm even to the end.

I also want to express my gratitude to the entire Physics Electronics option family as well as the entire 500 level class of Science Laboratory Technology (2023/2024 Session)

TABLE OF CONTENTS

Title page - - - - -	i
Certification - - - - -	i
Dedication - - - - -	iii
Acknowledgments - - - - -	iv
Table of contents - - - - -	v
List of figures - - - - -	vi
List of tables - - - - -	vii
Abstract - - - - -	viii
CERTIFICATION	ii
DEDICATION	iii
1.2 AIM OF STUDY	2
OBJECTIVES OF STUDY	3
1.5 SCOPE OF STUDY	3
Types of Motion detectors (Sensors)	9
CHAPTER THREE	15
METHODOLOGY AND DESIGN	15
3.1 MATERIALS FOR CONSTRUCTION	15
3.1.1 TRANSFORMERS	15
3.1.2 Diodes.....	17
3.1.3 CAPACITORS.....	18
3.1.4 RESISTORS	19
3.1.5 MICROCONTROLLERS	19
3.1.6 RELAYS	20

3.1.7 TRANSISTORS	21
3.2 METHODOLOGY	22
3.2.1 POWER SUPPLY	23
3.2.2 CONTROL UNIT	23
3.2.4 Controller Flowchart.....	24
3.2.5 RELAY UNIT CIRCUIT	26
3.2.6 SENSORS CIRCUIT	28
3.2.7 LEDS AND BUTTONS	29
3.2.8 WORKING PRINCIPLE.....	32
CHAPTER FOUR	33
SYSTEM TESTING IMPLEMENTATION AND EVALUATION	33
4.2 TEST PLAN	33
4.2.1 SIMULATION	33
4.2.2 POWER SUPPLY TEST	34
4.2.3. RELAY CIRCUIT TEST	35
4.2.4. CONTROLLER TEST	36
4.3 BILL OF CONSTRUCTION MATERIAL AND ESTIMATION	37
CHAPTER FIVE	39
DISCUSSION AND CONCLUSION	39
5.1 DISCUSSION.....	39
5.2 CONCLUSION	41
REFERENCES.....	42

LIST OF FIGURES

Figure 2.1: SOUND DETECTOR	-8
Figure 2.2: PASSIVE INFRARED (PIR) SENSOR	10
Figure 2.3: ULTRASONIC DETECTOR (SENSOR)	11
Figure 3.1: A TRANSFORMER	16
Figure 3.2: PARTS OF A TRANSFORMER	17
Figure 3.3: BLOCK DIAGRAM OF A BRIDGE DIODE	18
Figure 3.4: DIFFERENT TYPES OF CAPACITORS	19
Figure 3.5: A RESISTOR	20
Figure 3.6: A MICROCONTROLLER	21
Figure 3.7: A RELAY MODULE	22
Figure 3.8: A BI POLAR JUNCTION TRANSISTOR	23
Figure 3.9: SYSTEM BLOCK DIAGRAM	24
Figure 3.10: POWER SUPPLY CIRCUIT	24
Figure 3.11: CONTROL CIRCUIT	25
Figure 3.12: CONTROLLER FLOWCHART	27
Figure 3.13: RELAY CIRCUIT	29
Figure 3.14: SENSOR CIRCUIT	30
Figure 3.15: BUTTON AND LED SETUP	30
Figure 3.16: COMPLETE CIRCUIT DIAGRAM	32
Figure 4.1: POWER SUPPLY SETUP	34
Figure 4.2: RELAY SETUP	35
Figure 4.3: CONTROLLER CIRCUIT TEST	36

LIST OF TABLES

Table 1: Power supply test results - - - - -	35
Table 2: Bills of engineering measurement and estimation - - - - -	37
Table 3: Total calculation - - - - -	38

ABSTRACT

The importance of home security is increasing, and systems are constantly being improved. Sophisticated firearms, security guards, alarms, and other security measures have all been improved. Software and electronic hardware have also been invented. One of the most crucial safety measures that are necessary for all social groupings is home security.

The system architecture entails the integration of sound and motion detectors with a central processing unit, enabling real-time monitoring and response to potential security breaches. Leveraging advanced sensor technologies, the system can accurately identify unauthorized intrusions and trigger appropriate alarm responses. Key components of the system include high-sensitivity sound sensors capable of detecting anomalies such as breaking glass or forced entry, coupled with motion detectors that utilize passive infrared technology to detect movement within designated areas. These sensors are interconnected with a central control unit programmed to analyze sensor inputs and initiate alarm protocols when suspicious activity is detected. The system incorporates user-friendly interfaces for configuration and monitoring, allowing users to customize alarm settings and receive real-time alerts via mobile devices or computer interfaces. Additionally, the system's scalability and flexibility enable integration with existing security infrastructure, making it suitable for a wide range of residential, commercial, and industrial applications.

CHAPTER ONE

INTRODUCTION

1.1 BACKGROUND OF STUDY

The importance of home security is increasing, and systems are constantly being improved (Ijamaru *et al.*, 2023). Sophisticated firearms, security guards, alarms, and other security measures have all been improved. Software and electronic hardware have also been invented (Bader *et al.*, 2021). One of the most crucial safety measures that are necessary for all social groupings is home security. (Weber, 2019). Every home should be constantly watched for instances of theft, fire, and short circuits. These days, there is a concerning rise in the number of crimes, such as robbery, fire, and murder (Weber, 2019). Therefore, to increase its value, home security systems should be upgraded.

The need for further security measures is growing every day in majority of emerging nations, making one of the most important fundamental needs is security (Jabbar *et al.*, 2019). The necessity for robust security architecture in residential and commercial areas is critical due to the rise in crime rates. According to preliminary research, homes equipped with an effective, safe home security system are less likely to have burglaries (Elfasakhany *et al.*, 2021). The early men employed crude tools like stones, grasses, and other materials in an attempt to secure their homes and property, more value was added to lives and properties as invaders' methods of entry become more sophisticated, and to guarantee an atmosphere that is impenetrable to intruders, advanced methods were devised (Chooruang and Meekul, 2019). Many people would like to have a security system that monitors and alert them in case of emergency especially when they are away. Many products in the market are expensive, complicated and require the system to be linked to a public emergency system. However, people are looking for a low cost and simpler solution.

Despite all the effort, resources and time that has been devoted to the development of tools that will reduce crime rates and make the world a safer place to live, these problems are still on the increase (Hossain *et al.*, 2020). These gave rise to the need for an increasing development in the technology of alarm systems which utilizes various principles such as infrared motion detection,

light (photo) sensitive electronic devices and so on. Even with the introduction of these alarm systems which have reduced greatly the level of insecurity, there is still a problem of false alarm which needs to be minimized (Alarm.org, 2019). With the advancement in science and technology, these crude methods of generating alarm were replaced by electronic alarm systems in the late eighteenth century (Wazid *et al.*, 2020). These electronic alarm systems operate without any human effort. Once it senses a particular signal, it gives an indication in form of loud sound or noise depending on its design (Petruzzellis, 2021). The first electronic fire alarm system was developed by Dr. William f. Channing and constructed by Mr.-Moses G. Farmer, an electrical engineer (Icee.org, 2022). This system uses boxes with automated signaling to indicate the location of fire and was first put into operation in Boston in the United State of America (U.S.A). The development of this alarm system by Dr William was followed with the evolution of fire and burglar alarm technology of varying complexities and sophistications which are too numerous to mention. Notable among these technologies is the remote signaling intruder alarm system which was invented in the early 1970's (Wazid *et al.*, 2020). This provided a rapid art full response to alarm calls.

However, industries based on security service equipment provision have being coming up with different designs so as to keep burglars and vandals away from public areas not made for them (Zungeru, 2019). Today we have the new generation of electronic alarm system which comes in various levels of complexities and sophistication (Waller, 2019). With the recent increase in crime rates, it has become important to protect our buildings and properties with adequate safety devices with increased level of sophistication. The cost of these safety devices depends on the equipment technology and the application requirement. These safety devices are called the modern electronic alarm system (TargetWoman - Women Portal, 2024). The design and construction of a security and alarm system are thoroughly examined in this thesis, with a focus on the integration of motion and sound detectors. This study attempts to address the current issues related to the protection of diverse settings in addition to adding to the body of information already available on security systems.

1.2 AIM OF STUDY

The aim of this study is to Design and Construct a Security and Alarm System with Sound and Motion Detectors.

OBJECTIVES OF STUDY

The objectives of the study are

1. To develop a robust security and alarm system.
2. Integrate advanced sound detection technology to identify and distinguish various audio patterns associated with potential security threats.
3. Implement precise motion detection algorithms to accurately identify and respond to unauthorized movements within the monitored area.
4. Design a notification system that promptly alerts the user or security personnel upon detection of suspicious sounds or movements.
5. Design the system to support multiple sound and motion detectors, ensuring comprehensive coverage across distinct zones.
6. To optimize power consumption and ensure sustainable operation.

1.4 PROBLEM STATEMENT

In this thesis, a complete security and alarm system with integrated sound and motion detectors is proposed. Public confidence is undermined by traditional security measures' susceptibility to manipulation and false alarms. The system's objectives are to increase precision, decrease false positives, and respond to different security scenarios. The research will look at the difficulties in integrating sound and motion detectors, maximize sensor sensitivity, and guarantee that the gadget works in a variety of settings. The system will use a variety of communication channels to transmit real-time notifications, guaranteeing that swift action is taken in the event of a threat. If this method is successful, it might transform security guidelines and enhance the protection of people and property.

1.5 SCOPE OF STUDY

This thesis proposes a comprehensive security and alarm system that integrates sound and motion detectors to enhance protection against intruders. The project involves a thorough requirements analysis, system design, prototype development, system testing, system integration, maintenance, and evaluation. The system will be designed to meet security requirements, ease of use, reliability, and cost-effectiveness. The system will be integrated into existing properties or

installed in new ones, following best practices for installation, wiring, grounding, and safety. A maintenance plan will be developed to ensure system efficiency. The system's effectiveness will be evaluated based on predefined criteria, and any necessary improvements will be implemented. The thesis concludes with a summary of key findings, recommendations for further research, and reflections on the future of security system development.

1.3 Relevance of study

The importance of sound and motion detectors in modern safety infrastructure cannot be overemphasized. These systems serve as deterrents against potential intruders, aiding in crime prevention and early detection. They also facilitate real-time monitoring, allowing for immediate actions to prevent theft or vandalism. The integration of sound and motion detectors with other technologies enhances the overall security infrastructure, allowing for remote monitoring and control. The combination of sound and motion detectors with alarm systems reduces response times to potential security threats, minimizing damage or harm. A well-designed security system contributes significantly to the safety of occupants within a property, fostering a secure environment for all stakeholders. Thus, sound and motion detectors are vital components in modern safety protocols, ensuring the protection of assets and individuals in an increasingly complex security landscape.

CHAPTER TWO

LITERATURE REVIEW

2.1 OVERVIEW OF CURRENT SECURITY SYSTEMS

Security systems are networks of integrated electronic devices working together with a central control panel to protect against burglars and other potential home intruders (safewise, 2022). Security systems play a crucial role in safeguarding assets, both digital and physical, from unauthorized access, breaches, and potential threats. With the increasing reliance on technology and interconnected networks, the need for robust security measures has become paramount (Andrzejewski, 2020). This overview explores the key components and principles of modern security systems, highlighting their importance in protecting sensitive information and maintaining the integrity of various environments.

2.1.1 COMPONENTS OF SECURITY SYSTEMS

Security systems are multifaceted structures designed to protect assets, information, and individuals from various threats. Within the realm of security, several components play vital roles in ensuring comprehensive protection. These components include access control systems, surveillance systems, intrusion detection systems (IDS), firewalls and network security, and physical security measures.

Access control systems serve as gatekeepers, managing entry and exit points to designated areas or information. Employing methods such as biometric authentication, smart cards, and PIN codes, these systems ensure that only authorized individuals gain access, thus mitigating the risk of unauthorized entry and data breaches (Smith, 2019). Surveillance systems form another critical component by providing real-time monitoring and recording of activities. Through technologies like video cameras, facial recognition, and analytics, these systems enhance threat detection capabilities, enabling security personnel to identify and respond promptly to potential risks (Jones *et al.*, 2020). Intrusion detection systems (IDS) are designed to identify and respond to unauthorized activities within networks or physical premises. By monitoring for anomalous behavior, IDS trigger alerts or responses, enabling security teams to mitigate threats before they escalate (Anderson, 2019). Firewalls and network security mechanisms act as barriers between trusted internal networks and untrusted external networks. They prevent unauthorized access and

safeguard against cyber threats by employing techniques such as encryption and intrusion prevention systems (Harrison and Smith, 2021). Physical security measures complement digital protection by safeguarding physical assets and premises. Barriers, locks, and surveillance cameras are among the tools utilized to deter intruders and ensure the physical security of a facility (Doe, 2022). Integration is essential for maximizing the effectiveness of security systems. By coordinating access control, surveillance, and intrusion detection systems, organizations create a holistic security infrastructure that enhances overall protection (Williams and Brown, 2023).

However, security systems face challenges and must adapt to emerging trends to remain effective. One significant challenge is the evolving landscape of cybersecurity threats, which require continuous updates and proactive measures to counter (Chen *et al.*, 2020). Additionally, the integration of artificial intelligence (AI) introduces opportunities for faster threat detection and response but also raises ethical considerations and concerns about potential biases in AI systems (Gupta and Kumar, 2021).

2.2 ANALYSIS OF TRADITIONAL SECURITY MEASURES

The foundation for protecting digital and physical assets from various attacks has always been traditional security procedures. These precautions include a variety of techniques and tools intended to reduce risks and guarantee the safety of important assets. Using information from several research projects and academic publications, we will examine the shortcomings and efficacy of conventional security mechanisms in this analysis (Gonçalves *et al.*, 2021)

2.2.1. PHYSICAL SECURITY MEASURES

In order to safeguard material assets, physical security measures entail the installation of physical barriers and controls. Security guards, surveillance cameras, and access control systems are some of these precautions. According to studies, physical security measures are essential for preventing unwanted entry (Smith, 2018). For instance, surveillance cameras serve as a deterrent

and support investigative efforts, while access control systems might limit admittance to just authorized individuals. (Patel *et al.*, 2020).

However, it is important to note that physical security measures may have vulnerabilities. For instance, surveillance cameras can be tampered with or bypassed, and security personnel may be susceptible to human errors or collusion (Brown, 2019). Therefore, a holistic approach that combines physical security with other layers of protection is recommended for comprehensive risk management.

2.2.2 LIMITATIONS OF TRADITIONAL SECURITY MEASURES

While traditional security measures have proven effective in many scenarios, they are not without limitations. One common challenge is the inability to address insider threats adequately. Studies have shown that a significant percentage of security incidents are caused by employees or trusted individuals within an organization (De Bruijn and Janssen, 2017). Traditional measures often struggle to differentiate between legitimate and malicious activities from insiders.

2.3 OVERVIEW OF SOUND AND MOTION DETECTORS

Sound and motion detectors are critical components in various technological applications, ranging from security systems to home automation. These detectors play a pivotal role in detecting changes in the environment and triggering appropriate responses.

2.3.1. SOUND DETECTORS (SENSOR)

Sound detectors, also known as acoustic sensors, operate based on the principles of detecting changes in acoustic signals (Patel *et al.*, 2021). These devices typically consist of a microphone that captures sound waves, and the variations in these waves are analyzed to identify specific patterns or disturbances. Sound detectors are pivotal components of modern security systems, offering a layer of surveillance that complements traditional visual monitoring (Johnson, 2018). By leveraging advanced audio sensing technologies, these systems can detect and analyze sound patterns to identify potential threats, intrusions, or abnormal activities. Sound detection has become an essential component of security. It can isolate suspicious sounds amidst everyday noise and pinpoint what video surveillance often cannot: gunfire, shattered glass, trigger alarms

from cars and within corridors, and various forms of aggression. Sound detection immediately alerts security staff in real time and sends them speeding to the source (Garcia and Wang, 2017).



Figure 2.1: SOUND DETECTOR

photo credit: ((Patel *et al.*, 2021).

Functionality of Sound Detectors

Sound detectors operate by capturing and analyzing audio signals within their environment. They employ various techniques such as microphones, signal processing algorithms, and machine learning models to differentiate between normal background noise and suspicious sounds. These systems can be programmed to recognize specific acoustic signatures associated with unauthorized access, breaking glass, gunfire, or distress calls. By continuously monitoring audio inputs, sound detectors can trigger alerts or alarms in response to detected anomalies, enabling swift intervention by security personnel.

Applications of Sound Detectors

Sound detectors find widespread applications across different sectors, including residential, commercial, and industrial settings. In residential security systems, they provide homeowners with enhanced intrusion detection capabilities, alerting them to potential break-ins or disturbances. In commercial establishments such as banks or retail stores, sound detectors can help prevent theft or vandalism by detecting suspicious activities like forced entry or glass breakage. Moreover, in industrial facilities where safety is paramount, these systems can identify hazardous situations such as equipment malfunctions or environmental emergencies based on specific sound patterns.

2.3.2 MOTION DETECTOR (SENSOR)

A motion sensor is a device designed to detect moving things, primarily human motion. Often, a motion sensor is built into a system to notify a user of motion in an area or to carry out a job on a regular basis (ElProCus, 2019). These sensors are a crucial part of energy-efficient, automated lighting management, home control, security, and other useful systems. The primary function of a motion sensor is to detect intruder activity and notify your control panel, which then notifies your monitoring center. Motion sensors respond to a variety of events, such as movement in your living room and doors and windows that are closed or unbolted. These sensors may also activate a doorbell when someone comes close to the front door. These sensors give you an alert whenever kids enter into some restricted areas in the home such as medicine cabinet, the basement or workout room. Conserve energy by using this sensor lighting in empty spaces.

Types of Motion detectors (Sensors)

There are various kinds of motion sensors available in the market, which have their ups and downs. They are namely PIR, Ultrasonic, Microwave and Tomographic.

1. Passive Infrared (PIR) detector (Sensor)

Passive Infrared (PIR) sensors are remarkable devices that detect infrared radiation emitted by objects within their field of view. They operate on the principle of detecting changes in heat signatures rather than emitting infrared radiation themselves, hence the term "passive. Every warm-blooded mammal emits infrared radiation (Lee *et al.*, 2018) One component of passive infrared sensors is a thin Pyroelectric film material, which produces electricity in response to infrared light.

Mode of Operation

PIR sensors rely on a fundamental understanding of infrared radiation. All objects with a temperature above absolute zero emit infrared radiation (Chen, *et al.*, 2019). PIR sensors contain a pyroelectric sensor that generates an electric charge when exposed to infrared radiation. This charge is proportional to the temperature difference between the sensor and the detected object. When an object moves within the sensor's detection range, it alters the distribution of infrared radiation, causing a change in the electric charge and triggering the sensor (Karki *et al.*, 2018).



Figure 2.2: **Passive Infrared (PIR) Sensor** photo credit:(electronics.org)

Motion detectors play a vital role in enhancing security by providing early detection of potential threats, allowing for timely response and mitigation. However, it's essential to select the

appropriate type of motion detector based on the specific requirements and environmental conditions of the installation site. Regular maintenance and testing are also crucial to ensure the continued effectiveness of the security system.

2 Ultrasonic detector (sensor)

Ultrasonic sensors can be either active or passive; passive sensors listen for certain noises, such as glass breaking or metal hitting metal. Although these sensors are highly sensitive, they are often costly and prone to false alarms. Active ones produce pulses of ultrasonic waves, also known as sound waves, and then measure how these waves reflect off of moving objects. Fish, dogs, and cats are among the animals that can detect sound waves; therefore, an active ultrasonic alarm may frighten them. An ultrasonic detector, or sensor, is a device that utilizes ultrasonic waves to detect various objects or measure distances. Ultrasonic waves are sound waves with frequencies higher than the upper audible limit of human hearing, typically above 20 kHz. Ultrasonic detectors offer several advantages, including high accuracy, reliability, and the ability to work in various environmental conditions. However, they also have limitations, such as reduced effectiveness in environments with high levels of noise or dust, and limited range compared to other distance sensing technologies like LiDAR. Nonetheless, their versatility and cost-effectiveness make them valuable tools in a wide range of applications.



Figure 2.3: ULTRASONIC DETECTOR (SENSOR) **photo credit:** (electronics.org)

2.4 REVIEW OF RELATED WORK ON SECURITY AND ALARM SYSTEMS.

Designing and Implementation of Security alarm system for organizations, industries, and houses based on Global System for Mobile Communications (GSM) technology was review by Prasad and Sai ram susheel, that administer double ways to implementing security alarm system using internet of things. Firstly, is by the use of web cameras, in a case when there is any motion sensed by the camera, it will sound an alarm and sends a message to the industries, organizations, or homeowners that they are an intrusion (Prasad and Sai ram susheel, 2019). Daniel and Karri in the year 2021, they suggest to use internet facilities to deliver an alert or messages to the place an intrusion took place rather than the ordinary short message service (SMS) (Daniel and Karri, 2021). Arvind and Jayashri 2023 have carried out a fingertip or fingerprint-based verification system to unlock a certain closed place or door. This type of security system aids users to unlock a certain place because they are the ones whose fingerprint is register to the system so if you put the unregistered fingertip, it will not unlock the place or anything the finger is registered to (Arvind and Jayashri 2023). Guiawa *et al.*, (2018), developed a compact home security system based on the Global System for Mobile Communication (GSM). The system consists of a motion sensor, temperature sensor, and gas sensor, all controlled by an ATMEGA 8 microcontroller. The motion sensor detects intruders, the temperature sensor alerts the owner when the temperature exceeds a certain value, and the gas sensor detects smoke and gas, sending SMS alerts to the owner. This system helps prevent intruders, accidents, and fire outbreaks in homes, offices, and industries (Guiawa *et al.*, 2018). (Nosiri., *et al.*, 2019), designed a microcontroller-based security system for indoor geo-location using motion detectors. The system integrates cameras and motion detectors into a web application, controlling the Raspberry Pi camera for remote sensing and surveillance. The system alerts owners via SMS and buzzes alarms when intrusion occurs. The system offers a cost-effective, efficient, and easy-to-implement surveillance solution. Budijono *et al.*, (2021), design a home security device capable of swiftly sending alerts to the user's GSM (Global System for Mobile) mobile device via SMS (Short Messaging System) and enabling system control through SMS commands. The modular design of this Home Security System allows for the expansion of its capabilities by adding additional sensors. The hardware components of this system include a microcontroller AT Mega

328, a PIR (Passive Infra-Red) motion sensor for detecting motion, a camera for image capture, a GSM module for SMS communication, and a buzzer for alarm alerts. As for the software, Arduino IDE is utilized for programming the Arduino microcontroller, and Putty is employed for testing the GSM module's connectivity. This Home Security System is capable of monitoring the surrounding area using PIR sensors, sending SMS alerts, saving captured images, and triggering the buzzer to alert individuals in the event of detected trespassing. The Modular Home Security System has undergone successful testing and has proven its ability to detect human movement effectively (Budijono *et al.*, 2021). (Zungeru, 2013), designed an ultrasonic motion detection which emit ultrasonic sound waves into a designated area, which then reacts to changes in the reflected energy pattern. This detection system relies on a method that detects movement or changes in position by analyzing shifts in the frequency of the reflected energy. In this setup, ultrasonic sound is emitted from a transmitting device, typically in the form of energy, and travels through the air in wave-like motion. These waves bounce off the surroundings in the room or hallway, and the device registers a characteristic pitch indicative of the environment being monitored. When motion is detected, the wave pattern is disrupted and reflected back more rapidly, resulting in an increased pitch that triggers an alarm.

The primary innovation of this project lies in the creation of a circuit capable of detecting motion through the movement of any object, offering a cost-effective and portable motion detection solution. Additionally, another circuit was designed to activate or deactivate another circuit based on its attachment. Generally, the design is intended to identify movement or moving objects within a confined area. In this system, a transmitter transducer produces a signal at a frequency of 40kHz. When this signal is obstructed by a moving object, it activates a buzzer through a timing circuit. This system operates on the principle of signal interference caused by a moving body and relies on the presence of an intruder or moving object within the monitored area. Following its design and construction, the system underwent testing and was found to perform in accordance with specifications (Zungeru, 2019).

2.5 USES OF THE PROJECT

Security and alarm systems with sound and motion detectors play a crucial role in enhancing the safety and protection of homes, businesses, and various other environments. Here are some common uses and benefits of such systems:

1. **Burglar Deterrence:** Motion detectors can sense unauthorized movement within a premises, triggering alarms that can deter burglars and intruders.
2. **Intrusion Detection:** Sound and motion detectors can identify unauthorized access to a property, alerting occupants or security personnel immediately.
3. **Property Protection:** These systems help safeguard valuable assets, such as electronics, jewelry, and other high-value items, by providing early detection of potential theft.
4. **Home Security:** Protecting homes with security systems can provide peace of mind for residents, especially when they are away. The system can notify homeowners and security services about any suspicious activity.
5. **Fire Detection:** Some security systems include smoke and heat detectors, enhancing overall safety by alerting occupants to potential fires or smoke.
6. **Emergency Response:** Security systems can be linked to emergency services, providing a faster response time in case of a break-in or other security breach.
7. **Pet Safety:** Motion detectors can be adjusted to account for the presence of pets, minimizing false alarms while still maintaining security.
8. **Monitoring of Sensitive Areas:** Security and alarm systems with detectors are valuable for monitoring specific areas within a property, such as entrances, windows, or secure rooms.
9. **Business Security:** Commercial establishments benefit from these systems by protecting assets, confidential information, and ensuring the safety of employees.
10. **Insurance Premium Reduction:** Installing security systems with motion and sound detectors may lead to reduced insurance premiums for homeowners and businesses, as they demonstrate a commitment to safety.
11. **Remote Monitoring:** Many modern security systems can be monitored remotely through mobile apps, allowing users to receive alerts and check the status of their property in real-time.
12. **Integration with Smart Home Systems:** These security systems can often be integrated with other smart home devices, allowing for automated responses, such as turning on lights or locking doors when an intrusion is detected.

CHAPTER THREE

METHODOLOGY AND DESIGN

3.1 MATERIALS FOR CONSTRUCTION

To guarantee that the system functions properly, and construction of a security and alarm system with sound and motion detectors. The following are the primary parts utilized in this project:

1. Transformer
2. Adaptable box
3. Jumper wires
4. Connector
5. Condenser microphone
6. Microcontroller
7. Diodes
8. Ceramic capacitors
9. Small polarized
10. Small polarized capacitor
11. Push buttons
12. Relay
13. Transistor (NPN)
14. Light emitting diodes
15. Buzzers
16. Batteries
17. Power module (transformers and regulators)

3.1.1 TRANSFORMERS

Based on the idea of Faraday's Law of Electromagnetic Induction, which states that "the magnitude of voltage is directly proportional to the rate of change of flux," a transformer is an electrical component that transfers electrical energy from one circuit to another without requiring the addition of external power or altering the frequency of the electrical waves (Kokotovic, 2019). When a current passes through one of the coils in a transformer, it generates a magnetic

field that subsequently induces a voltage across the other coils wrapped around the same core (Electrical4U, 2019).

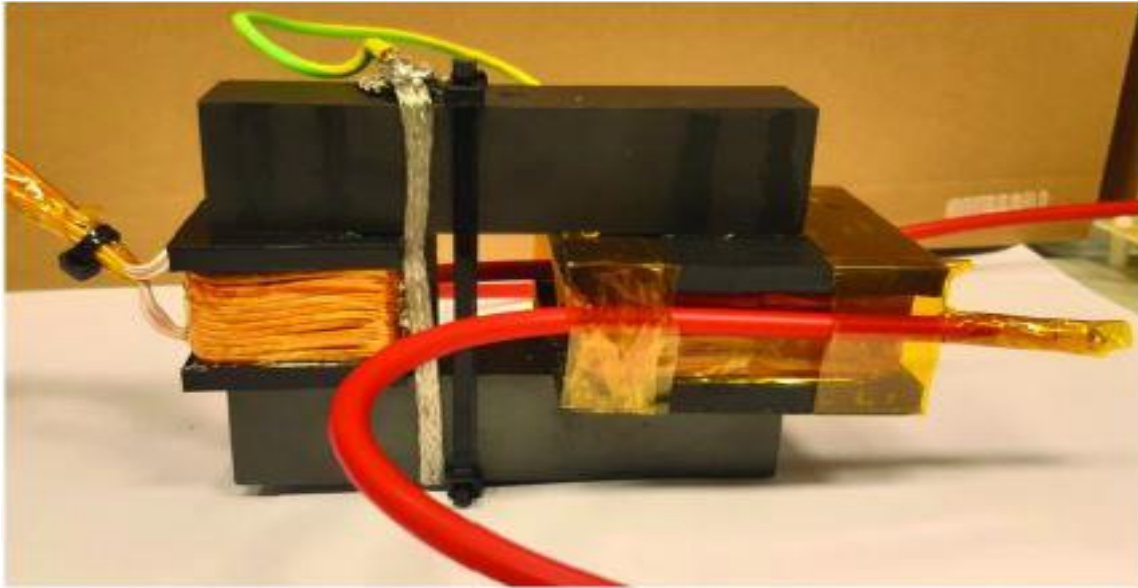

FIGURE 3.1: A TRANSFORMER (Villegas *et al.*, 2022)

PARTS OF A TRANSFORMER

- 1. Windings:** These are set of copper wires wrapped around the transformer core. There are two major types of winding (Abror, 2020).
 - **Primary windings:** Primary winding of transformer produces magnetic flux when it is connected to an electrical source (Abror, 2020).
 - **Secondary windings:** The magnetic flux produced by primary winding passing through the core links with the secondary winding. The set of turns of winding from which output is taken (Abror, 2020).
- 2. Magnetic Core of Transformer:** This serves as the support to the winding in the transformer and provides a low reluctance path to the flow of magnetic flux. The core diameter is directly proportional to copper losses and inversely proportional to iron losses (Lloyd, 2021).

3. Insulation Agents: Insulation is important in transformers to separate windings from each other and to avoid short circuits. Insulation influences the durability and stability of a transformer. Insulating tape, paper, oil and wood-based lamination are the types of insulation medium (Dalessandro *et al.*, 2017).

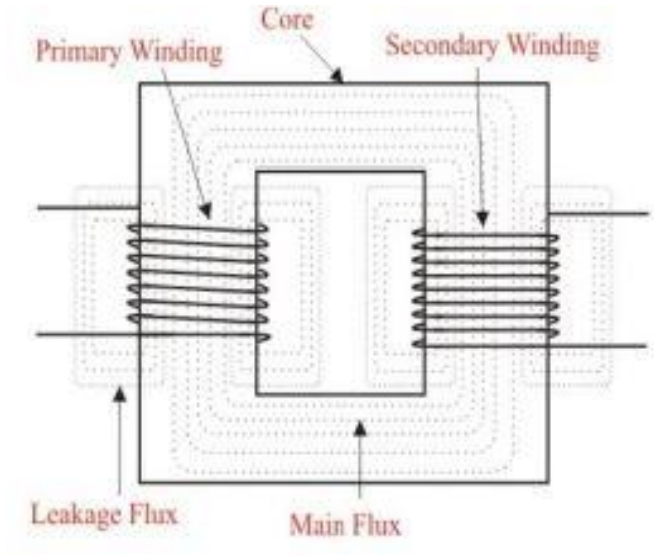

Figure 3.2: PARTS OF A TRANSFORMER (Electrical4U, 2019)

3.1.2 Diodes

A diode is an electrical component that only permits one direction of current passage (Tooley, 2020). Rectification is one of the numerous uses for diodes. In particular, diodes are used to convert alternating current (AC) on the input terminals to direct current (DC) on the output terminals in a bridge rectifier circuit, which consists of four diodes. A diode bridge is used to change the negative voltage sections of an AC waveform to positive voltage. No matter which way the input polarity goes, the output polarity never changes (Mike, 2019).

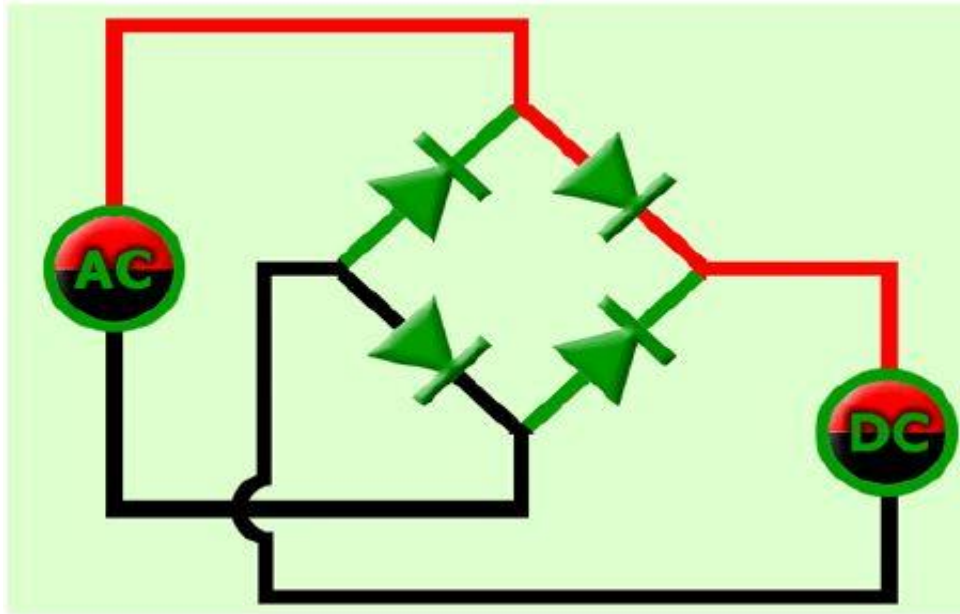

Figure 3.3: BLOCK DIAGRAM OF A BRIDGE DIODE (Strzelecki and Benysek, 2018)

3.1.3 CAPACITORS

A capacitor is a device that works by keeping separate pairs of opposing charges in order to store electrical charge and energy. It is made up of two electrical conductors spaced apart by an insulating substance known as a dielectric or by a vacuum. Capacitance (Chenming, 2019; Sze and Lee, 2022) is the capacity of the capacitor to hold these charges.



Figure 3.4: Different types of capacitors (Wikipedia, 2023)

3.1.4 RESISTORS

A resistor is a passive electrical component that has two terminals and prevents electricity from flowing through it in a circuit. Resistors are frequently used in circuits to balance out active parts like op-amps, microcontrollers, and other integrated circuits. Resistors are frequently used to split voltages, draw up I/O lines, and restrict current (Jelten *et al.*, 2021).



Figure 3.5: A Resistor (Zubaer *et al.*, 2020)

3.1.5 MICROCONTROLLERS

Microcontrollers (MCUs) are tiny, basic personal computers (PCs) that lack a comprehensive front-end operating system (OS) and are intended to control certain functions of a bigger component (Lutkevich, 2023). This part processes the data, decides which switch to make, and monitors the voltage and available phase supply from the alternate power source or the national grid. It is also in charge of the LCD screen. According to Keim (2019), a microcontroller is a single chip that consists of a CPU, memory, and input/output (I/O) peripherals. They are used in a variety of applications, including industrial control systems, motor control systems, display unit peripheral interface systems, SMPS and power regulation systems, embedded systems, and boards for the Arduino UNO, Arduino NANO, and Arduino MICRO (Compton and Jameson, 2018).

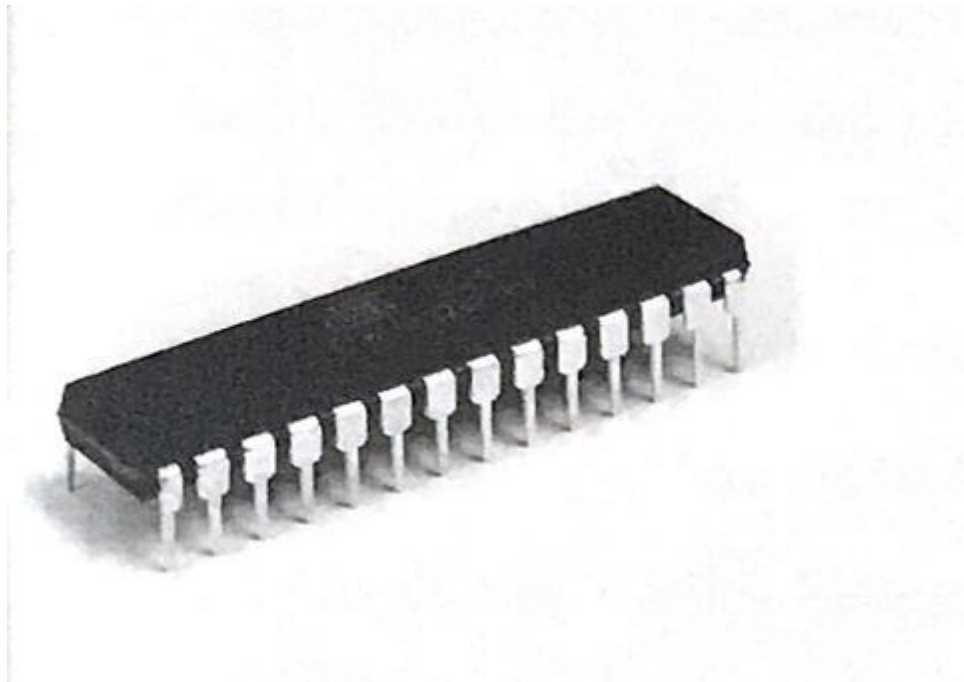

Figure 3.6: Microcontroller (Compton and Jameson, 2018)

3.1.6 RELAYS

A relay is an electromagnetic switch operated by small electric current which turns on or off large electric current. Relays work on the principle of electromagnetic induction by using an electrical signal to control an electromagnet, which in turn connects or disconnects another circuit (Prasad, 2022). Relays are used to protect the electrical system and to minimize the damage to the equipment connected in the system due to over voltages (Zheng *et al.*, 2021). There are numerous types of relays such as high voltage relay, solid state relays, timer relays, thermal relays, frequency protection relays, and more (Vladimir Gurevich, 2016).



Figure 3.7: A Relay Module (Hattaraki *et al.*, 2020)

3.1.7 TRANSISTORS

A transistor serves as a switch and an amplifier; they are a semiconductor device that conducts and insulate electrical voltage/current. Transistors are three terminal device that regulates the flow of electrical currents, enables fast switching, and are used to develop a single integrated circuit (Turner, 2018).

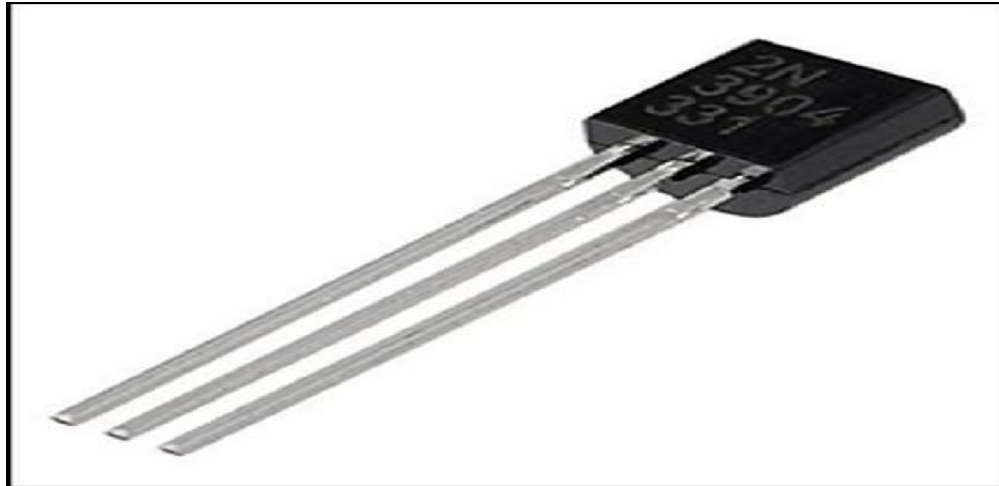

Figure 3.8: A Bipolar junction transistor (Othman, 2019)

3.2 METHODOLOGY

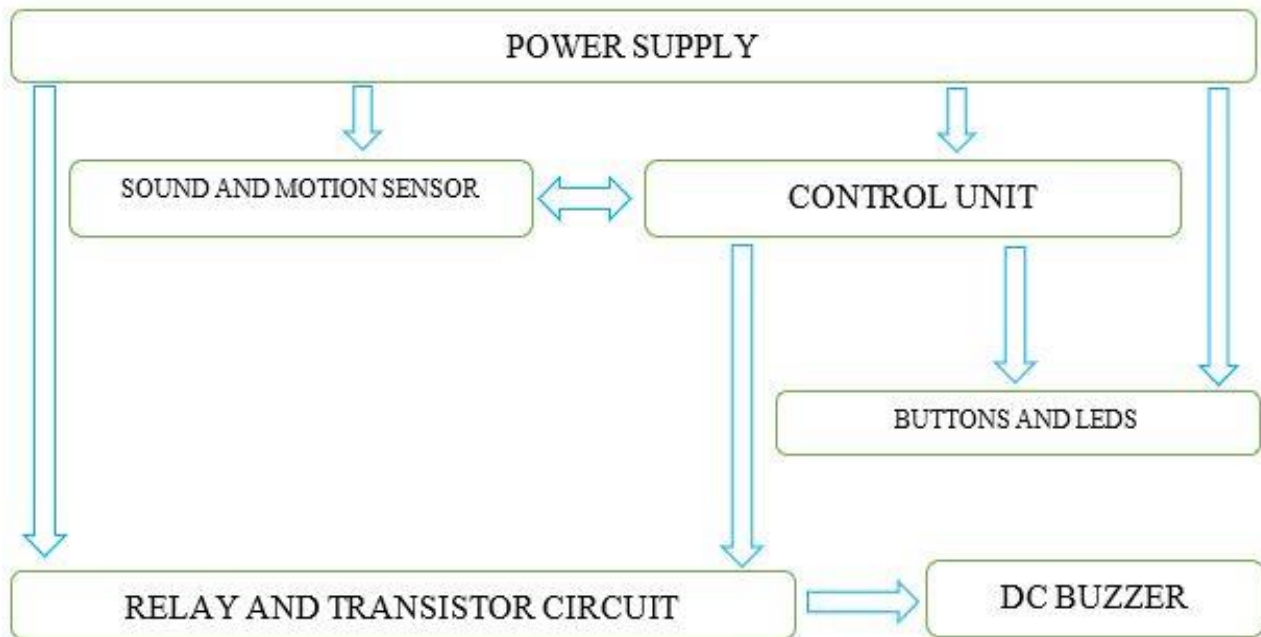

FIGURE 3.9 SYSTEM BLOCK DIAGRAM

3.2.1 POWER SUPPLY

The voltage requirement for this project includes; 5V and 8V. The power supply is a combination of a switch mode power supply (Ac-DC 12v 2A Power module) and two 4v batteries connected in parallel to form an 8V battery system.

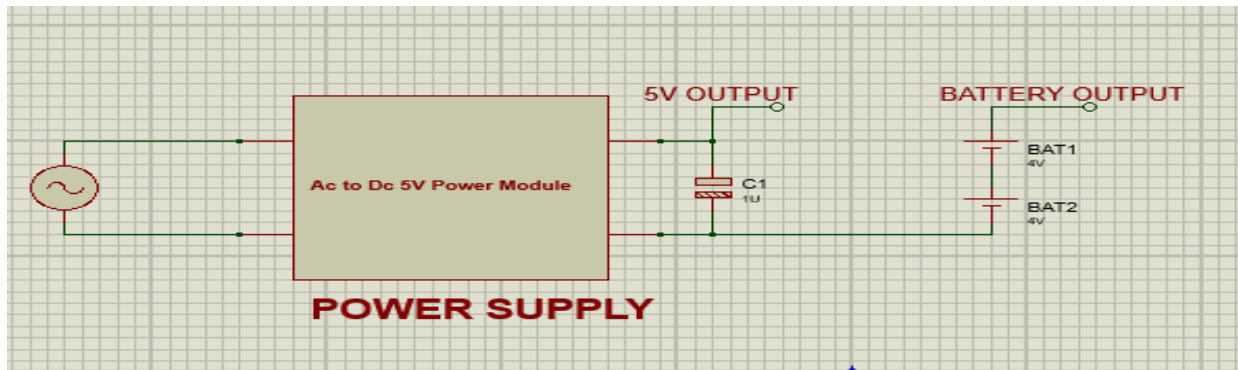

FIGURE 3.10: POWER SUPPLY CIRCUIT

The 5V output of the power module is connected to the controller circuit, the sensor circuit and the LED circuit while, the parallel battery connect is connected to the dc water pump.

3.2.2 CONTROL UNIT

The control unit comprises the microcontroller (PIC16F887), crystal oscillator circuit and the master clear reset circuit which in turn consist of a resistor and a capacitor. The microcontroller is the main control unit which controls the on and off status of the relay under the influence of the microcontroller. The crystal oscillator controls the timing of the microcontroller which means the time at which the microcontroller execute one instruction. The microcontroller frequency is one-fourth of the crystal oscillator frequency. The master clear reset circuit helps to prevent the microcontroller from resetting by continuously connects the master clear pin of the microcontroller to power through a resistor and ceramic non-polarized capacitor connected to ground. The figure below shows the circuit diagram of the control unit. Capacitors connected from the crystal oscillator to ground are meant to stabilize the crystal oscillator signals to the microcontroller.

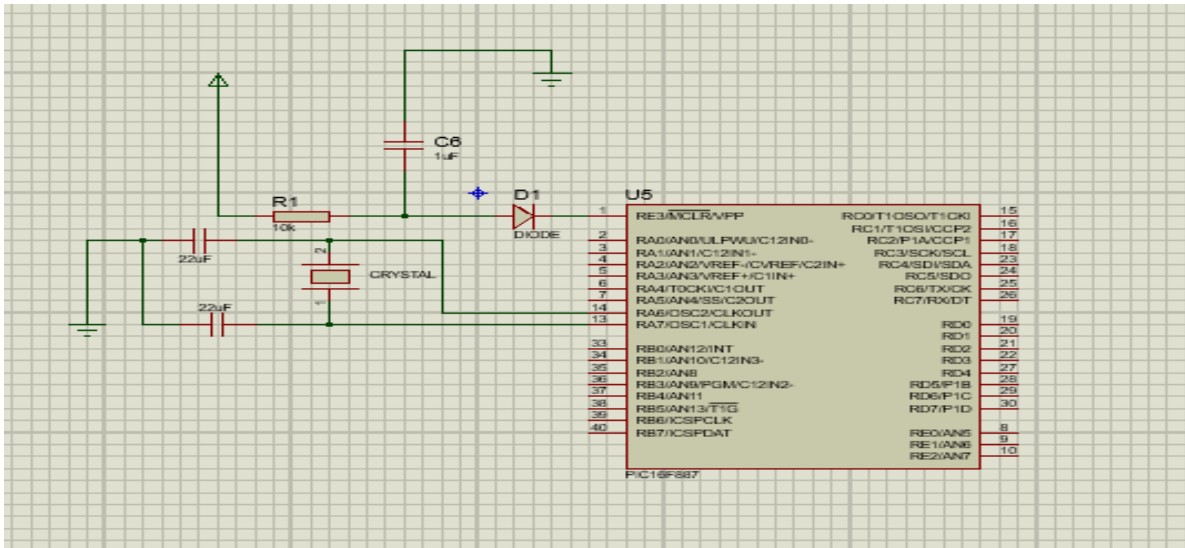

FIGURE 3.11 CONTROL CIRCUIT

R1 = 10K (Recommended in PIC microcontroller datasheet)

C6 = 100nF (Recommended in PIC microcontroller datasheet)

C10 = C11 = 22pF (Recommended in PIC microcontroller datasheet)

3.2.4 Controller Flowchart

The journey through the controller flowchart begins with the pivotal step of system initialization and device configuration. At this juncture, the system lays the foundation for its operations by setting up parameters and configurations necessary for efficient functioning. This initial phase establishes the groundwork upon which subsequent actions will unfold, ensuring that the system operates within predefined parameters.

Following system initialization, the flowchart proceeds to check the status of devices through sensors and configuration settings. This step serves as a critical checkpoint, enabling the system to gather real-time data from sensors and assess the current state of connected devices. By leveraging this information, the controller can make informed decisions regarding the management of device operations.

Upon evaluating device status, the flowchart navigates through conditional pathways based on user input. If the control button is pressed, the system initiates actions tailored to maintain optimal conditions within the controlled environment. Herein lies the essence of automation –

the ability to respond dynamically to user commands and environmental cues, thereby enhancing operational efficiency and user experience.

One pivotal aspect of device control entails regulating temperature levels within a designated space. In accordance with the flowchart, if the room temperature falls below a predetermined threshold, the system takes corrective action by turning off the temperature control mechanism. Conversely, if the room temperature surpasses a predefined upper limit, the system activates temperature regulation to mitigate overheating.

The iterative nature of the controller flowchart is exemplified by the continuous monitoring and adjustment of device operations. As long as the controller remains active, it perpetually cycles through the decision-making process, ensuring that devices operate optimally and in accordance with user-defined parameters. This iterative loop encapsulates the essence of continuous improvement and adaptation inherent in automated systems.

Ultimately, the controller flowchart culminates in a termination condition whereby the system halts its operations. This final step serves as a safety mechanism, ensuring that the system disengages gracefully when no longer required or when encountering an error condition. By adhering to predefined termination criteria, the system mitigates the risk of unintended consequences and safeguards both devices and users.

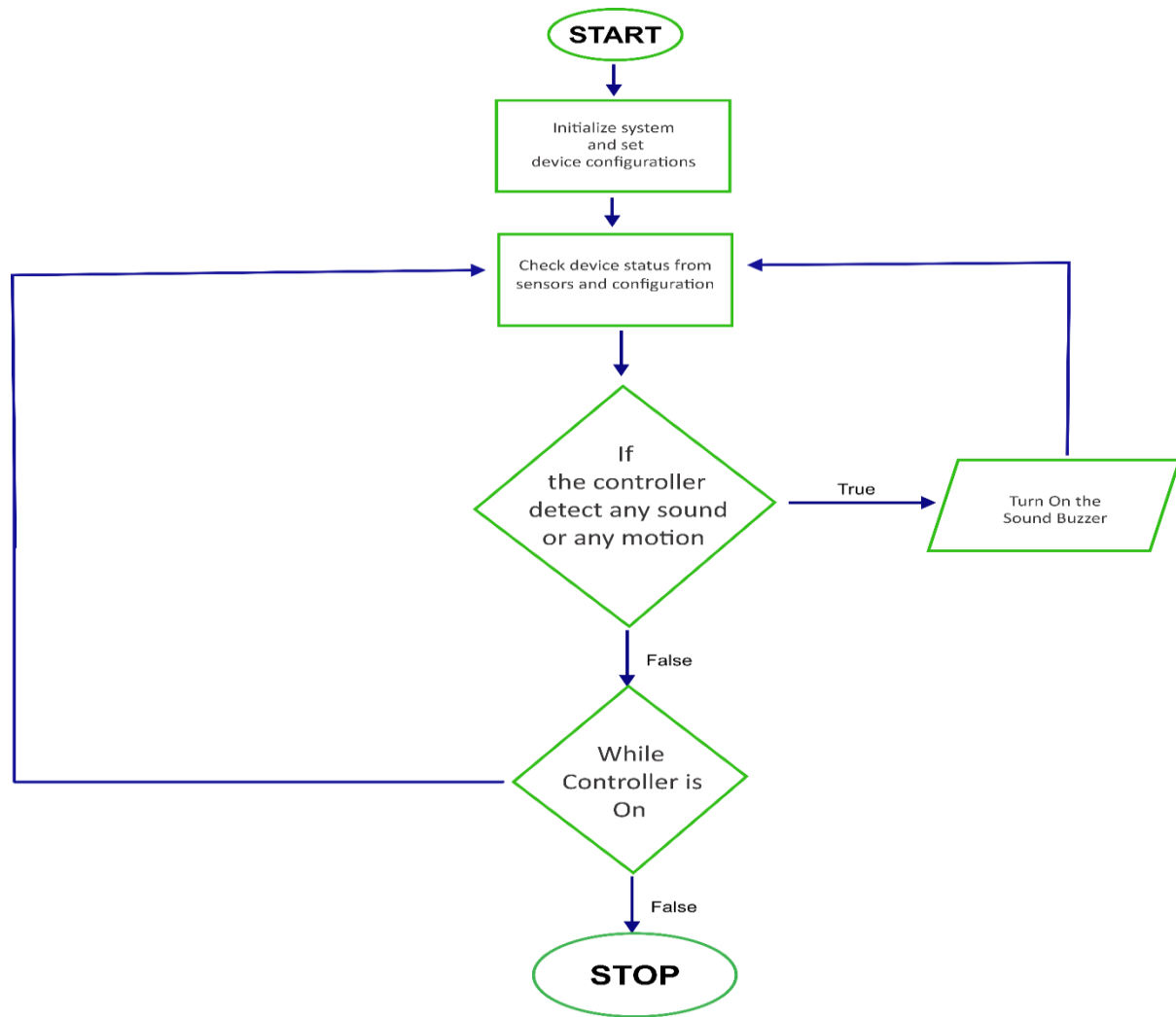

FIGURE 3.12 CONTROLLER FLOWCHAT

3.2.5 RELAY UNIT CIRCUIT

The relay circuit consist of a 5V 10amp relay used to switch the Dc Fan On and Off. The circuit also have a NPN transistors (bc547) to sink the relay actuator pin. The transistors under the control of the microcontroller (PIC16F887) can turn ON or OFF the corresponding relay by sinking the current at relay actuator. Each transistor is connected to the microcontroller through a 10k ohms biasing resistor. The microcontroller can supply up to 5V, 25 milli-amps signal which go through the resistor and bias the transistor, which turns ON the transistor there by turning ON

the Dc Fan. When the voltage signal is removed, the transistor goes OFF there by turning OFF the Dc Fan.

CALCULATION OF TRANSISTOR BASE RESISTOR

The nominal current of a 5V relay is about 70mA. This value represents the I_c of the circuit, which is the current flowing from Collector of the transistor to the Emitter of the transistor. To calculate the resistor needed to bias the transistor at the base we use ohm's law.

$$V = IR$$

$$R = \frac{V}{I}$$

In this case, R is R_b , V is the potential difference between Base and Emitter. Therefore,

$$R_b = \frac{V_b - V_{be}}{I_b}$$

But,

$$I_b = \frac{I_c}{\beta}$$

Where β is the transistor gain and the value is 200. And I_c is 70mA. Therefore,

$$I_b = \frac{70 \times 10^{-3}}{200}$$

$$I_b = 0.35mA$$

Assuming V_b is 5v, voltage supplied by the microcontroller, V_{be} is 0.2v voltage at the transistor junction.

$$R_b = \frac{5 - 0.7}{0.35 \times 10^{-3}}$$

$$R_b = 12.285k,$$

10k ohms was used as the biasing resistor for the transistor because it is hard to get the exact 12.285k ohms.

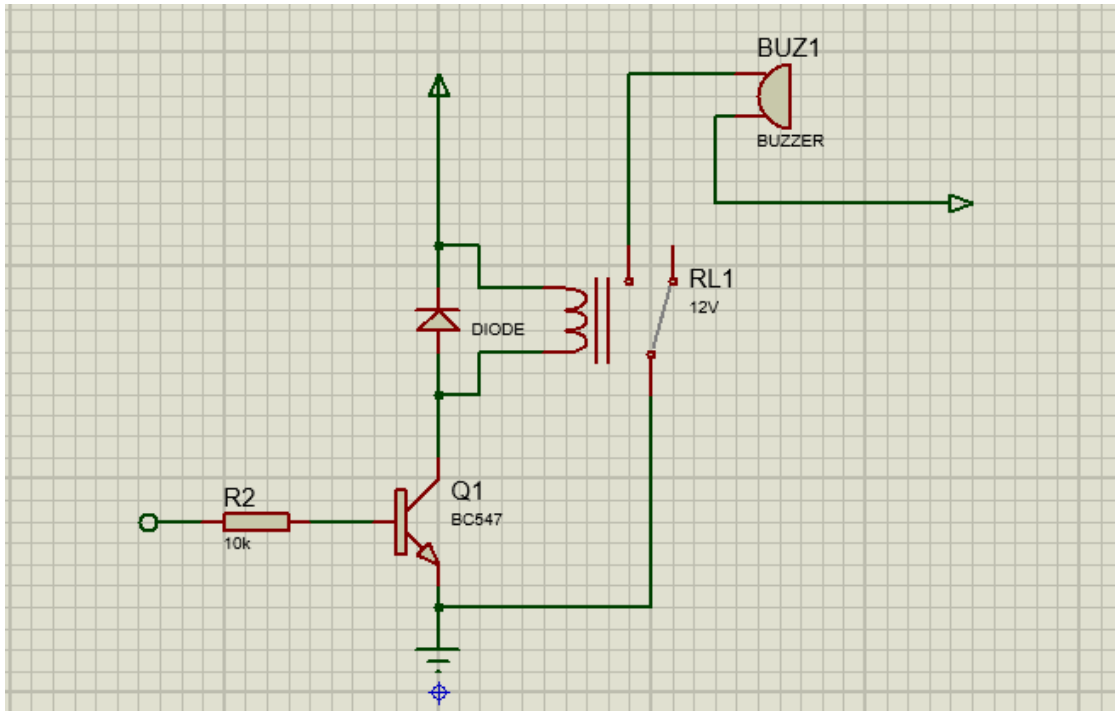

FIGURE 3.13 RELAY CIRCUIT UNIT

3.2.6 SENSORS CIRCUIT

The sensor circuit is a combination of the two-motion sensor and three sound sensor circuits. The motion sensor circuit detects whether or not there is noticeable motion along its path. If the motion sensor detects any motion along its path it sends a wave signal to the microcontroller, while if the motion doesn't detect any motion along its path the microcontroller doesn't get any wave from the motion sensor. When the motion sensor detects any motion it requires a cool down period for it to be able to adequately sense further motion after a cool down period.

Also the sound sensors send a high signal to the microcontroller it can detect any audible sound in the surroundings.

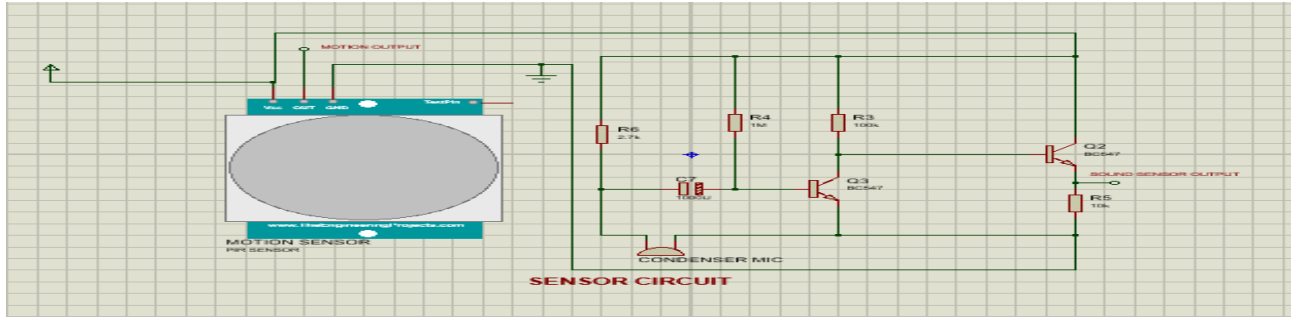

FIGURE 3.14 SENSORS CIRCUIT

3.2.7 LEDES AND BUTTONS

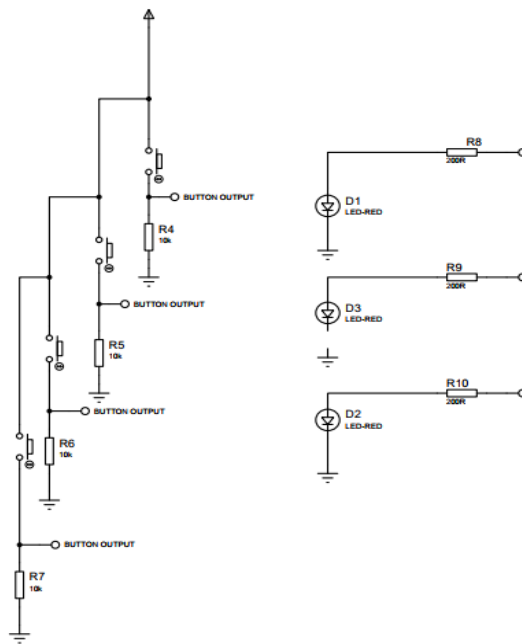

FIGURE 3.15 BUTTON AND LED SETUP

The setup for the Light Emitting Diodes (LED) and buttons circuit is show in the figure 4.3 above. The setup consists of 4 push buttons, four 10k ohms resistors and a 5volts power input for the Button section. And 3 red LEDs and three 200 ohms resistor for the LED section.

The button circuit uses a pull-up button configuration (ACTIVE HIGH) where the button is active when its output measures a high signal (2.5V -5.5V). Before a button is pressed or pushed, the output measured is 0.00 V (LOW). When the button is pressed or pushed, the momentary voltage measured at the output is 4.98 V (HIGH), Therefore this configuration is considered pull-up or active high configuration. The 10k ohms resistor connected between output and ground is to prevent direction current flow from power to ground (SHORT CIRCUIT).

LED RESISTOR CALCULATION

From Ohm's law;

$$V = IR \quad \text{----- eqn1}$$

$$V_e = V_s - V_{led} \quad \text{-----eqn1.1}$$

$$V_e = V \quad \text{-----eqn1.2}$$

Substituting eqn1.2 into eqn1

$$V_e = IR \quad \text{-----eqn1.3}$$

Substituting eqn1.1 into eqn1.3

$$V_s - V_{led} = IR \quad \text{-----eqn1.4}$$

Make R the subject of formula

$$R = \frac{V_s - V_{led}}{I} \quad \text{-----eqn1.5}$$

$$I_{led} = I \quad \text{-----eqn1.6}$$

Substituting eqn1.6 into eqn1.5

$$R = \frac{V_s - V_{led}}{I_{led}} \text{-----eqn1.7}$$

Where;

V = Voltage

V_e = Effective Voltage

V_s = Supply Voltage

V_{led} = Led Forward Voltage

I_{led} = Led Forward Current

R = Resistance

From the Equation 1.7 above;

$$R = \frac{5 - 2}{20 \times 10^{-3}}$$

V_s = 5v

V_{led} = 2v for red LED

I_{led} = 20mA – 50mA

$$R = 150 \text{ ohms.}$$

Therefore, the resistor used for the LED can range between 120ohms to around 200ohms, depending on the brightness you want to achieve.

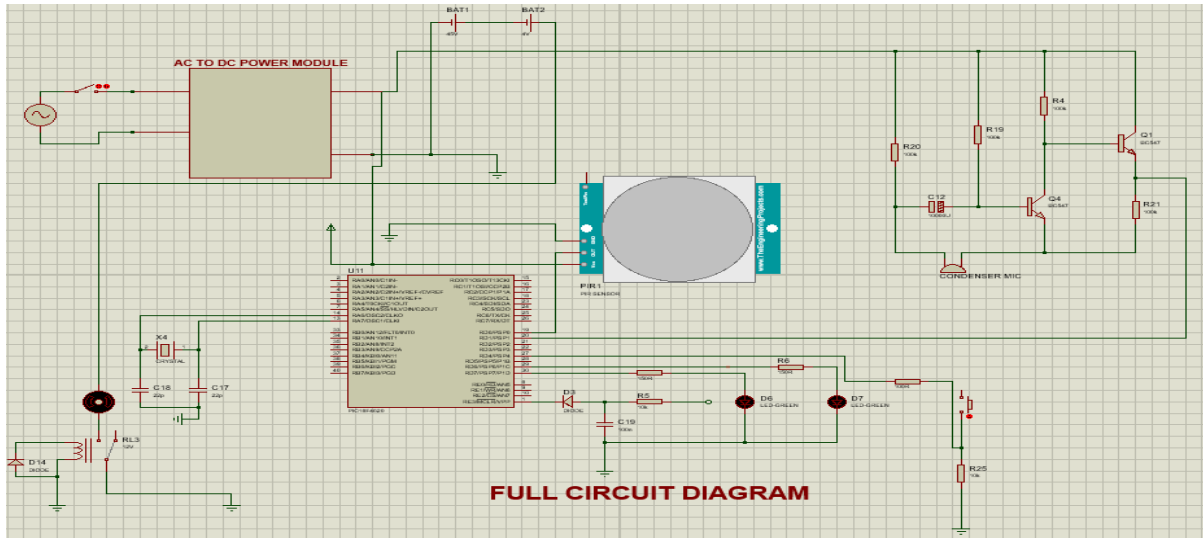

3.16 FIGURE COMPLETE CIRCUIT DIAGRAM

3.2.8 WORKING PRINCIPLE

The project entry point is the power supply which is made up of the combination of an Ac to Dc power supply module. The 5V is used to power the microcontroller unit, 5V relay the temperature sensor and every other part of the circuit. When the system comes on, the microcontroller configures the device and set every necessary data like the waiting period of the motion sensors.

When the microcontroller senses audible sounds from using the sound sensors or any motion from the motion sensors, the controller actuates the relay connected to the buzzer to turn ON the buzzer and the sound stays ON till the reset button is pressed and a 30min delay is observed before the sensors are active again to check for sounds and motion.

CHAPTER FOUR

SYSTEM TESTING IMPLEMENTATION AND EVALUATION

4.1 SYSTEM TESTING

Upon completion of the model, testing is vital to ensure that the system functions optimally based on the aim of the project. The model contains different components and circuitry that has to be tested individually and subsequently, together, to ensure that first, the components work well, the individual circuits perform the function they have been designed to form, and the entire system function well.

4.2 TEST PLAN

The test plan encompasses all the steps taken in checking the functionality of each module that makes up the entire system design.

4.2.1 SIMULATION

The test plan begins with a simulation of the complex work using an electronics software called Proteus. The simulation test result provided assurance that the system design was feasible and fully functional in its logical decision.

4.2.2 POWER SUPPLY TEST

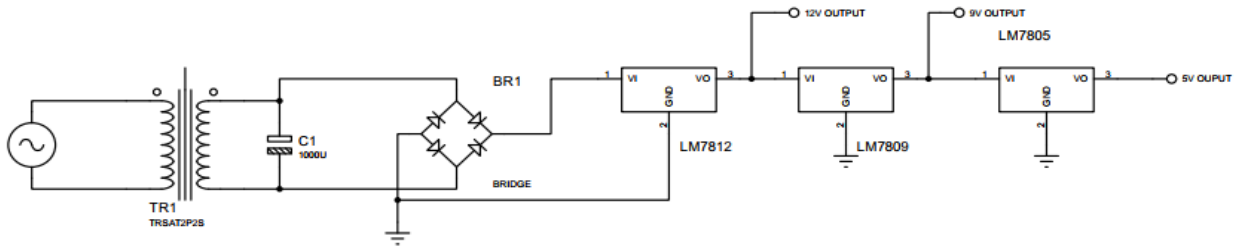

Figure 4.1: POWER SUPPLY SETUP

The setup for the power supply test circuit is shown in the figure 4.1 above. The setup comprises of a 220V – 2x15V step down transformer, a bridge diode, a 1000uf 100v filtering capacitor, 3 linear voltage regulators (L7805CV, L7809CV, L7812CV). This test was carried out with no load connected.

AC INPUT	5VOLTS OUTPUT	8VOLTS OUTPUT
212.35 V	5.04V	8.08 V
215.57 V	5.08 V	8.11 V
204.17 V	5.06 V	8.03 V
195.19 V	4.99 V	8.01 V
188.20 V	4.97 V	7.95 V

Table 1: POWER SUPPLY TEST RESULTS

Table 4.1 shows that there is a negligible voltage drop in the output of all the voltage regulators. This is because the input AC voltage dropped. From the table above it can be deduced that the

power supply design will still work fine. Even if the AC voltage input drop significantly to around 160V from the 220V expected, the voltage drop at the voltage regulators will not be that significant to affect the system.

4.2.3. RELAY CIRCUIT TEST

The figure 4.5 below shows the setup for the relay circuit, simulated in the Proteus CAD software. The setup above consists of three 5V 10A relay, one 12V 20A – 30A relay, four 2N3904 NPN transistor and four regular diodes. Considering the setup above, the normally opened terminal of each relay is connected to a 220 AC input, the normally closed of each relay is not connected, while the common terminal of each terminal is connected to the load to be switched.

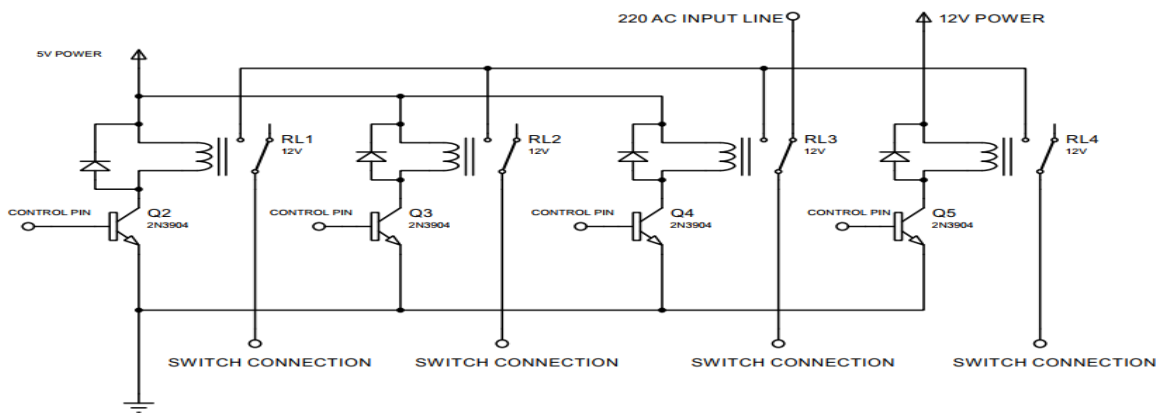

Figure 4.2: RELAY SETUP

The 2N3904 act as a secondary switch to actuate the corresponding relays connected to it which is the primary switch. For every high signal (2.5 – 5.5 volts) sent to the base of the transistor, the corresponding transistor ground (sinks) the relay cathode pin and actuate the corresponding relay. The diode is connected in reverse bias, this is to protect the circuit against transient current built up in the coil of the relay which can destroy the relay and other components connected in the circuit. The diode prevents transient by creating a path way for the built-up transient current to flow in the sudden switching of the relay state (on to off and off to on).

4.2.4. CONTROLLER TEST

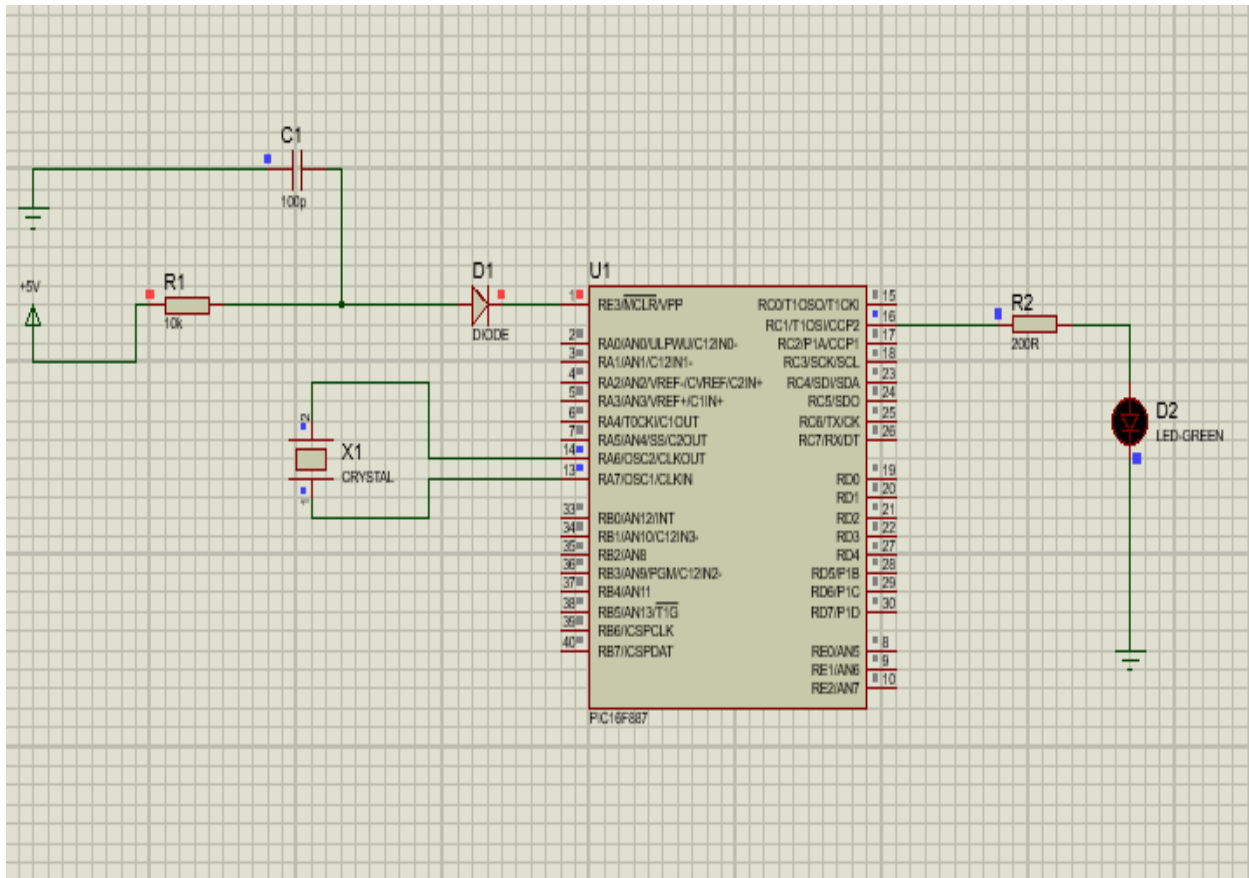

Figure 4.3: Controller circuit test

The figures 4.4 shows the setup for testing the microcontroller circuit simulated using the Proteus CAD software. This set consists of a microcontroller, an LED, two resistors, three ceramic capacitors, a crystal oscillator and a ground and 5v power terminal from the power supply. A simple code was uploaded into the controller to control turning ON and OFF the LED circuit connected to the controller to ensure that the controller circuit is working as intended.

4.3 BILL OF CONSTRUCTION MATERIAL AND ESTIMATION

Table 4.2 provides a list of all the materials used in the construction of security and alarm system with sound and motion detectors, alongside the quantity used, and the cost per unit price. Table 4.3 shows the total cost of materials and the total estimate for the project.

S/NO	PARTICULAR	RATE AND SPECIFICATON	QUANTITY	PRICE RATE (Naira)	TOTAL AMOUNT (Naira)
1	Vero Board	Strip Pattern	2	500	1000.00
2	Adaptable Box	9.5cm by 15.8cm	1	3000	3000.00
3	Jumper wire	1 yard	1	500	500.00
4	Connector	10 pins	5	300	1500.00
5	Condenser Microphone		4	100	400.00
6	Microcontroller	PIC18F4620	1	10000	10000.00
7	diodes	1A	2	100	200.00
8	Ceramic capacitors	104	10	20	200.00
9	Small Polarized Capacitors	50V, 10uf	10	100	1000.00
10	Push button		2	100	200.00
11	Relay	10A, 230V 5V DC	2	800	1600.00
12	Transistor (NPN)	BC547	5	200	1000.00
13	Light Emitting Diode	30mA	5	50	250.00
14	Buzzer	3V - 24V	1	1500	1500.00
15	Batteries	4V, 800mA	4	1000	4000.00
16	Power Module	12V 2A	1	3500	3500.00
17	Motion Sensor	5v	2	3000	6000.00

Table 4.2: Bill of construction material

S/NO	PARTICULAR	AMONUT (Naira)
1	Initial Total	35850.00
2	Miscellaneous	10000.00
3	Grand Total	45850.00

Table 4.3: Total calculation

CHAPTER FIVE

DISCUSSION AND CONCLUSION

5.1 DISCUSSION

This endeavor involves creating an alarm system with sound and motion detectors with microcontrollers serving as the central control and relays as the switching components. The initial step is setting up the power supply unit to generate the required 8 Volts DC output. Following the completion of the power supply circuit, a multimeter test is conducted to confirm the DC voltage falls within the specified range.

Furthermore, the relay circuit responsible for switching is assessed and found to be functioning correctly. Challenges are encountered in effectively operating the microcontroller initially. However, after some persistence, it successfully takes control of the entire switching process. This functionality is verified through testing the individual circuits of the project simultaneously.

Designing and implementing an alarm system with both sound and motion detection involves several key considerations, ranging from sensor selection to integration with a microcontroller or embedded system. Let's delve into the discussion on how one might approach such a project.

For sound detection, a common choice is an electret microphone sensor. This sensor can detect sound intensity and convert it into an electrical signal that can be processed by a microcontroller. Alternatively, specialized sound detection modules are available, which simplify the process of detecting sound events. Motion Detector (Passive Infrared) sensors are widely used for motion detection.

These sensors detect changes in infrared radiation within their field of view, typically triggered by the movement of warm objects such as humans or animals. Ultrasonic sensors or microwave sensors can also be used for motion detection, depending on the specific requirements of the project.

The microcontroller serves as the brain of the alarm system, processing inputs from the sensors and triggering appropriate actions. Popular choices for microcontrollers include Arduino boards, Raspberry Pi, or custom-designed microcontroller units (MCUs). The selection depends on

factors such as processing power, input/output capabilities, and available libraries or community support. **Sensor Integration** Connect the sound and motion detectors to the chosen microcontroller using appropriate interfaces (analog or digital). Configure the microcontroller to continuously monitor the sensor inputs for trigger events. Define the logic for triggering the alarm based on sensor inputs. For example, the alarm could be activated if the sound level exceeds a predefined threshold or if motion is detected within a specific range. Implement the alarm output mechanism, which could include sound generation (e.g., through a buzzer or speaker) and visual indicators (e.g., LEDs). The microcontroller controls these outputs based on the trigger conditions. Incorporate a user interface for configuring alarm settings, such as sensitivity levels for sound and motion detection. This could be achieved through physical controls (buttons or potentiometers) or a digital interface (LCD display and buttons). Ensure efficient power management to prolong the battery life or maintain operation during power outages. This may involve low-power modes for the microcontroller and sensors, as well as considerations for power supply and backup systems. Rigorously test the alarm system under various conditions to ensure reliable operation. This includes testing sensor sensitivity, trigger thresholds, alarm responsiveness, and overall system stability. Fine-tune the system parameters based on testing results and user feedback. This may involve adjusting sensor settings, refining trigger logic, or optimizing power consumption for extended operation.

Once the alarm system is fully tested and optimized, integrate it into the desired environment and deploy it according to the specific application requirements. This could include home security, industrial monitoring, or any other scenario where sound and motion detection are critical for alarm functionality.

In conclusion, designing and implementing an alarm system with sound and motion detection involves careful selection of sensors, microcontroller programming, and thorough testing to ensure reliable performance. By following a systematic approach and considering the key factors outlined above, one can create an effective alarm system tailored to their needs.

5.2 CONCLUSION

In conclusion, the design and implementation of an alarm system equipped with both sound and motion detection capabilities represent a significant stride in enhancing security measures for various environments. Throughout this project, we have delved into the intricacies of sensor technologies, circuit design, and software integration to create a robust system capable of detecting potential threats and alerting users promptly.

By combining sound and motion detection, our system provides a comprehensive approach to security, effectively covering a wide range of potential intrusion scenarios. The integration of these features ensures a higher level of accuracy in detecting unauthorized activities while minimizing false alarms, thereby enhancing the overall reliability of the system.

Furthermore, the flexibility and scalability of our design allow for customization and adaptation to specific requirements and environments. Whether deployed in residential homes, commercial spaces, or industrial facilities, the versatility of our alarm system ensures its applicability across various settings.

As we conclude this project, it is evident that the successful implementation of an alarm system with sound and motion detection capabilities holds immense potential in safeguarding properties and enhancing peace of mind for users.

Moving forward, further refinements and advancements in technology will continue to improve the effectiveness and efficiency of security systems, ultimately contributing to safer and more secure environments for individuals and communities alike.

REFERENCES

- Alarm.org. (2019, May 7). Alarm.org. <http://alarm.org>
- Anderson, J. (2019). "Security and Intrusion Detection Systems." *Journal of Security Engineering*, **12**(3): 45-58.
- Andrzejewski, K. (2020). Security information management systems. *Management Sciences*, **24**(4):1–9.
- Bader, Iman, Mahdi, Sami, & Soliman, M. S. (2021). Design and Implementation of a Reliable Wireless Real-Time Home Automation System Based on Arduino Uno Single-Board Microcontroller. *International Conference on Information and Communication Technology Convergence (ICTC). IEEE*.**19**(6):120-134.
- Brown, C. (2019). "Human Factors in Physical Security: Understanding the Risks." *Security Journal*, **35**(4):567-589.
- Budijono, S., Andrianto, J., & Axis Novradin Noor, M. (2019). Design and implementation of fusing laser rays International Journal for Scientific Research & Development” (IJSRD).
- Chen, S., Yu, T., Wang, P., (2020). "Cybersecurity Threats: Challenges and Solutions." *International Journal of Information Security*, **18**(2):123-145.
- Chooruang, K., & Meekul, K. (2018). *Design of an IoT Energy Monitoring System*. IEEE Xplore. Opportunities and Challenges." *Journal of Cybersecurity Research*, **8**(4):211-230.
Conferences, (68)25-47. <https://doi.org/10.1051/epjconf/20146800025>
- De Bruijn, H., & Janssen, M. (2017). Building Cybersecurity Awareness: The need for evidence-based framing strategies. *Government Information Quarterly*, **34**(1):1–7.
<https://doi.org/10.1016/j.giq.2017.02.007>
- Doe, M. (2022). "Physical Security Measures: A Comprehensive Guide." *Security Journal*, **25**(1):89-102.
- Elfasakhany, A., Hernández, J., García, J. C., Reyes, M., & Martell, F. (2021). Design and Development of a House-Mobile Security System. *Engineering*, **3**(12):1213–1224.

- Govinda K, Sai. P. K. and Sai. S (2017) "Intrusion detection system for smart home Challenges and Solutions." *International Journal of Information Security*, **18**(2):123-145.
- Guiawa, M., Ofusori, T. J., Olusuyi, K. O., Ezea, H. U., & Babarinde, A. K. (2017). Design and Implementation of a Compact Home Security System. *FUOYE Journal of Engineering and Technology*, *2*(2). <https://doi.org/10.46792/fuoyejet.v2i2.70>
- Gupta, R., & Kumar, A. (2021). "Artificial Intelligence in Security: Opportunities and Challenges." *Journal of Cybersecurity Research*, **8**(4):211-230.
- Harrison, R., & Smith, P. (2021). "Network Security: Principles and Practices." *International Journal of Computer Networks*, **15**(2), 78-95.
- Hossain, R., Biswas, H., Al Banna, M. H., Degadwala, S. (2020). Design and Implementation of Smart Security System for Farm Protection From Intruders. *International Journal of Scientific Research in Computer Science, Engineering and Information Technology*, 250–263.
- <https://www.facebook.com/safewise>. (2022, October 12). *What is a Security System and How Does it Work?* SafeWise. <https://www.safewise.com/home-security-faq/how-do-security-systems-work/>
- Icee.org. (2022). <http://www.icee.org/organization/history>
- Ijamaru G.K., Adamu M. Z., Sandra, Y., Adedayo K. B., & Olusuyi K. Oluwafemi., (2023). Design and Construction of an Automatic Triggered Bell Ringer Circuit. *Innovative Systems Design and Engineering*, **5**(12):91–98.
- Intrusion”, 1st International Conference on Sensing Technology, Palmerston North, New Zealand, November 21 -23.
- Jabbar, W. A., Kian, T. K., Ramli, R. M., Zubir, S. N., Zamrizaman, N. S. M., Balfaqih, M., Shepelev, V., & Alharbi, S. (2019). Design and Fabrication of Smart Home With Internet of Things Enabled Automation System. *IEEE Access*, *7*, 144059–144074.
- Jones, A., jones, W.A., Benard, R.T (2020). "Advancements in Video Surveillance Technologies." *Journal of Security Technology*, **22**(4): 176-192.
- Karri. V, Daniel Lim. J. S, 2021. "Method and Device to Communicate via SMS After a Security" *Journal of Security, Privacy and Trust Management*, **2**(1):1–13

- Smithson, E. (2019). "The Effectiveness of Firewalls in Modern Cybersecurity." *Cybersecurity Review*, **12**(4):321-340.
- Nosiri.C, C.C., A.-U., U.A., N. and C.H., E. (2019). Motion Detector Security System for Indoor Geolocation. *International Journal of Engineering and Applied Sciences (IJEAS)*, **5**(11): 22-35. doi:<https://doi.org/10.31873/ijeas.5.11.16>.
- Patel, S. K., Sharma, A., & Singh, G. S. (2020). Traditional agricultural practices in India: an approach for environmental sustainability and food security. *Energy, Ecology and Environment*. **2**(1):1–13
- Petruzzellis, T. (2021). *The Alarm, Sensor & Security Circuit Cookbook*. McGraw Hill Professional. **19**(3):67-81.
- Prasad, K. and Sai ram susheel (2019). INTRUSION DETECTION SYSTEM FOR SMART HOME USING LASER RAY? S. *International Journal for Scientific Research and Development*, **2**(3):176–178.
- Smith, L. (2019). "Biometric Authentication: A Review of Technologies and Applications." *Cybersecurity Today*, **11**(1):34-50.
- TargetWoman - Women Portal*. (n.d.). TargetWoman Women Information Portal. Retrieved February 8, 2024, from <http://www.targetwoman.com>
- Waller, I. (2019). *Science and Secrets of Ending Violent Crime*. Rowman & Littlefield. using laser rays International Journal for Scientific Research and Development” (IJSRD). **19**(3):67-81.
- Wazid, M., Das, A. K., Odelu, V., Kumar, N., Conti, M., & Jo, M. (2020). Design of Secure User Authenticated Key Management Protocol for Generic IoT Networks. *IEEE Internet of Things Journal*, **5**(1): 269–282.
- Weber, T.L. (2018). *Alarm Systems and Theft Prevention*. Saint Louis Elsevier Science. modular home security system with short messaging system. *EPJ Web of* **12**(3), 210-225.
- Williams, E., & Brown, K. (2023). "Integrated Security Systems: Enhancing Effectiveness through Coordination." *Security Management*, **19**(3):67-81.

- Wu, T., Wu, F., Redoute, J.-M., & Yuce, M. R. (2017). An Autonomous Wireless Body Area Network Implementation Towards IoT Connected Healthcare Applications. *IEEE Access*, 5, 11413–11422.
- Zungeru, A. M. (2019). A Simple and Reliable Touch Sensitive Security System. *International Journal of Network Security & Its Applications*, 4(5):149–165.
- Smith, J. (2019). "Advances in Sound Detection Technology for Security Applications." *Journal of Security Engineering*, 5(2): 45-58.
- Brown, A., Jones, B. (2020). "Integration of Audio Sensors into Modern Surveillance Systems." *Proceedings of the International Conference on Security Technology*, 123-136.
- Patel, R., Kumar, M.G. Khan, W.E. (2021). "Machine Learning Approaches for Anomaly Detection in Audio Surveillance." *IEEE Transactions on Information Forensics and Security*, 16(4):789-802.
- Johnson, L. (2018). "Applications of Sound Detection Systems in Industrial Safety." *Safety Engineering Journal*, 12(3), 210-225.
- Garcia, M., Wang, S. (2017). "Performance Evaluation of Sound Detectors in Residential Security Systems." *Journal of Applied Security Research*, 8(1): 67-80.
- ElProCus - Electronic Projects for Engineering Students. (2019). *Different Types of Motion Sensors and How They Work*. [online] Available at: <https://www.elprocus.com/working-of-different-types-of-motion-sensors/> [Accessed 26 Nov. 2019].
- Chen, K. Ching W.K. Chung L. (2019) "A microwave motion detector for security system applications." *IEEE Transactions on Microwave Theory and Techniques* 57(12): 2974-2981.
- Grob, M. (2015). Intrusion Detection Systems for Mobile Security. *Handbook of Mobile Systems Applications and Services*, 625-646.
- Karki, Sudip K, Basukala N. (2018)"PIR-based human detection system." *4th International Conference on Advances in Electrical Engineering (ICAEE)*. *IEEE*.4(2):223-457

Lee S.J, Sunghee J.W, Jong-Hyeon Y. (2018) "Design and implementation of ultrasonic sensor-based motion detection system for home security." *International Conference on Information and Communication Technology Convergence (ICTC)*. *IEEE*.**19**(6):120-134.