

**APPLICATION OF FINITE ELEMENT TO DEFORMATION MONITORING OF
PHYSICS DEPARTMENT BUILDING IN THE UNIVERSITY OF BENIN,
UGBOWO CAMPUS, EDO STATE NIGERIA.**

BY

MOLUNO CHUKWUEMEKE PROGRESS

ENV1805810



**UNIVERSITY OF BENIN
FACULTY OF ENVIRONMENTAL SCIENCES
DEPARTMENT OF GEOMATICS**

APRIL, 2024

**APPLICATION OF FINITE ELEMENT TO DEFORMATION MONITORING OF
PHYSICS DEPARTMENT BUILDING IN THE UNIVERSITY OF BENIN, UGBOWO
CAMPUS, EDO STATE NIGERIA.**

BY

**MOLUNO CHUKWUEMEKE PROGRESS
ENV1805810**

**A PROJECT SUBMITTED
IN PARTIAL FULFILMENT OF THE REQUIREMENTS FOR THE AWARD OF
BACHELOR OF SCIENCE (B.SC) DEGREE IN GEOMATICS, AT THE
UNIVERSITY OF BENIN, BENIN CITY, NIGERIA.
A PROJECT SUBMITTED TO THE DEPARTMENT OF GEOMATICS, FACULTY
OF ENVIRONMENTAL SCIENCES, UNIVERSITY OF BENIN, BENIN CITY.**

APRIL 2024

CERTIFICATION

This is to certify that this project was carried out by **MOLUNO CHUKWUEMEKE PROGRESS**, an undergraduate with the matriculation number **ENV1805818**, of the Department of Geomatics, Faculty of Environmental Sciences, University of Benin, Edo State, Nigeria.

ENGR SURV.PROF.EHIGIATOR.IRUGHE R.

DATE

Project supervisor

SURV. SHOLA OLADOSU

DATE

HEAD OF DEPARTMENT

EXTERNAL SUPERVISOR

DATE

DEDICATION

This project is dedicated to those whose unwavering support and inspiration have illuminated my academic path:

To my family, for their boundless love, encouragement, and sacrifices. Your steadfast belief in my potential has been my greatest motivation.

To my friends and peers, whose shared journey made the challenges more manageable and the successes more meaningful.

This project stands as a tribute to the collective impact of these individuals, without whom this journey would not have been as fulfilling.

ACKNOWLEDGEMENT

I want to sincerely thank everyone who contributed to the successful completion of my project. This project has been a journey full of obstacles and successes, and I am incredibly appreciative of the help and advice I have received.

Above all, I owe a debt of gratitude to my project adviser Engr. Professor Ralph Ehigiator-Irughe, R, for his unwavering support, constructive criticism, insights and corrections have been vital to the project's success, his constant commitment to research and academic success has served as a constant source of motivation.

Furthermore, I also extend my heartfelt gratitude to my assistant project supervisor, SURV. Mohammed Tijani, for his selfless dedication to ensuring the success of my project. My lecturers, technologists, administrative officers, and non-teaching staff at the Department of Geomatics, University of Benin, Ugbowo. Special acknowledgment goes to the Head of Department, Surv. Oladusu S.O, Surv. (Mrs.) Ekun M.O, Surv. Dr. G. O. Nwodo, Surv. Engr, Dr. Solomon Okonofua., and others for their unwavering efforts and contributions to my academic journey.

This project would not have been possible without the collective efforts of all those mentioned above. Each one has played a significant role, and I am sincerely thankful for their contributions.

MOLUNO CHUKWUEMEKE PROGRESS

ABSTRACT

This project explores the use of finite element analysis (FEA) methods for the Physics Department building's deformation monitoring. For buildings to remain structurally sound and safe, deformation monitoring is essential, especially for those that are subjected to changing loading bearing and climatic conditions over time. A comprehensive approach for modeling and assessing the structural behavior of complex structures, such as buildings, under various conditions is provided by the Finite Element Analysis (FEA) method. Taken into account its geometric, material, and loading properties, FEA is used in this work to model the Physics Department building. The assessment of the building's response to varying loads and environmental conditions involves the evaluation of several deformation parameters, including displacements, strains, stiffness and stresses.

The results of this study help in the construction of effective deformation monitoring plans for structures that are similar to the Physics Department building and offer insightful information about the structural integrity of the building.

The methodology involves the strategic placement of GNSS receivers, considering topographic features, and environmental factors. The selected GNSS receivers are equipped with advanced capabilities for precise positioning, enabling the monitoring of both static and real-time information. The project also integrates quality assurance measures, such as regular calibration checks, redundancy protocols, and real-time corrections, to ensure the reliability of the collected data.

The anticipated outcomes of this project include a comprehensive dataset detailing the deformations observed in the monitored structures area over a period.

Furthermore, the research advances finite element analysis (FEA) methods in structural engineering by improving their accuracy and practicality.

TABLE OF CONTENTS

Certification	i
Dedication	ii
Acknowledgments	iii
Abstract	v
List of Figures	xi
List of Tables	xii
CHAPTER ONE: INTRODUCTION	1
1.1 Background of Study	1
1.2 Statement of the Problem	2
1.3 Aim and Objectives	3
1.4 Scope of Study	4
1.5 Justification of the study	4
CHAPTER TWO: LITERATURE REVIEW	6
2.1 Meaning of Deformation	6
2.2 Types of Deformation	6
2.2.1 Elastic Deformation	7

2.2.2 Plastic deformation	7
2.2.3 Brittle deformation	7
2.2.4 Ductile deformation	7
2.2.5 Creep Deformation	8
2.3 Deformation monitoring	8
2.4 Types of Deformation Monitoring	10
2.4.1 Geodetic Deformation Monitoring	10
2.4.2 Geotechnical Deformation Monitoring	10
2.4.3 Structural Deformation Monitoring	10
2.4.4 Remote sensing Deformation Monitoring	11
2.4.5 Multi Sensor Deformation Monitoring	11
2.5 Advantages of Deformation studies	11
2.5.1 Early detection of Structural or ground movements	11
2.5.2 Structural health assessment	11
2.5.3 Risk mitigation and prevention of catastrophic failures	11
2.5.4 Improved understanding of deformation mechanisms	12
2.5.5 Cost-effective maintenance and decision-making	12
2.6 Data Analysis	12

2.6.1 Point Cloud Analysis	12
2.6.2 Time Series Analysis	13
2.6.3 Finite Element Analysis (FEA)	13
2.6.4 Multi-Sensor Data Fusion	14
2.7 Modelling and Prediction	14
CHAPTER THREE: METHODOLOGY	16
3.1 Study Location	16
3.2 Project planning and Reconnaissance	17
3.2.1 Project Planning	17
3.2.2 Office Reconnaissance	17
3.2.3 Field Reconnaissance	18
3.3 Equipment and instruments used	18
3.3.1 Data acquisition	19
3.4. Instrument set-up	20
3.5 Creating a Data Base for Monitoring the Structure	21
3.5.1 Data Collection and Analysis	22
3.5.2 Using Finite Element to determine the Deformation of the Structure	22
CHAPTER FOUR: Results and Analysis	24

4.1 Result and Discussion	24
4.2 Data and Analysis	27
4.2.3 Determination of the stiffness matrix of the elements	28
CHAPTER FIVE: SUMMARY, CONCLUSION, AND RECOMMENDATIONS	48
5.1 Summary	48
5.2 Recommendations	49
5.3 Conclusion	49
REFERENCES	51
APPENDIX	56

LIST OF FIGURES

Figure 3.1: Showing the study area	20
Figure 3.2: Sketch of the perimeter	24
Figure 4.2: Showing the building's cross section	28
Figure 4.3: Showing the Distance and bearing for data collected in week one	30
Figure 4.4 Showing the Distance and Bearing for data collected in week	39
FIGURE A.2 Showing MATLAB Analysis for the Global Matrix, Stiffness Matrix...	57
FIGURE A.3 Showing The Displacement Between week 1 and 2 for Triangle BCD	58
FIGURE A.4 Showing The Displacement Between Week 1 and 2 for Triangle BDA	58

List of Table

Table 4: Showing data collected	27
Table 4.2.1 showing the average Eastings and Northings for week one	29
Table 4.2.2 Showing the average Easting and Northings for week two	29

CHAPTER ONE

INTRODUCTION

1.1. BACKGROUND OF STUDY

The Deformation survey is a detailed investigation of how materials respond and adapt to external forces. Deformation refers to the change in shape, size or composition of a material when subjected to various stresses and is fundamental to understanding mechanical behavior and structural integrity of materials.

In the field of Engineering Survey, Deformation monitoring is a critical procedure in geodesy and surveying engineering, aiming to track changes in both natural and manmade structures over time. The fundamental challenge lies in the potential consequences of neglecting to monitor deformation, as it directly impacts the stability of structures on the Earth's surface (Perfetti et al., 2014). The repercussions of insufficient monitoring become apparent when considering various external and internal factors that can cause deformation.

Deformation monitoring is a major component of logging measured values that may be used for further computation, deformation analysis, predictive maintenance, and alarming. Deformation monitoring is primarily associated with the field of applied surveying but may also be relevant to civil engineering, mechanical engineering, construction, and geology. The measurement devices utilized for deformation monitoring depend on the application, the chosen method, and the preferred measurement interval. (Wikipedia, Jan 5, 2024).

A critical aspect of studying deformation lies in the comprehending the stress-strain relationships within the materials. Stress represents the force applied per unit area, while

strain refers to the resulting deformation. Understanding how stress and strain interrelate aids in defining a material's behavior under different loads and conditions. This knowledge is crucial in engineering designs to ensure that materials can withstand anticipated stress levels without undergoing failure.

Furthermore, learning about the physical properties of materials under various circumstances yields priceless knowledge. A material's response to deformation can be greatly influenced by variables like temperature, pressure, and time. For instance, elevated temperatures may lead to increased malleability in specific materials, hence endangering their structural integrity. Recognizing these patterns aids in forecasting how well and how long materials will last in practical applications.

Considering deformation directly affects the performance, safety, and design of engineering materials and structures, it is important to research deformation in surveying and engineering. With this information, surveyors and engineers can both anticipate and minimize future problems, improve designs, and choose the right materials for certain uses.

1.2. STATEMENT OF PROBLEM

Structural deformation poses an ongoing threat to the integrity of building infrastructure, potentially leading to catastrophic collapses with profound consequences for safety and the economy. Global instances of building failures highlight the risks associated with the gradual accumulation of damage and sudden, extreme events. In the context of aging structures like the physics department building at our university, diverse deformation mechanisms, from fatigue cracks to the relentless impact of severe weather, continually jeopardize occupant safety and institutional continuity.

This project focuses on introducing instrumentation and analytical methods designed to address specific deformation risks prevalent in Nigerian buildings due to environmental stressors. These stressors include:

1. Detecting foundation disturbances and material fatigue from chronic vibrations, such as those generated by traffic or machinery operations.
2. Identifying the accumulation of cosmetic and structural damage caused by intense seasonal harmattan winds and Saharan dust corrosion.

1.3. AIMS AND OBJECTIVES

The aim of this project is the Application of Finite Element to Deformation monitoring to oversee the structural changes within the Physics Department at the Faculty of Physical Sciences, University of Benin, Benin City.

The specific objectives are as follows:

- To use a finite element to determine the deformation of the structure.
- Systematically collect and analyze pertinent data to discern prevalent trends and patterns.
- To serve as a base study for the future observations and monitoring.
- Assess and determine the extent of deformation present in the physics department building.

OBJECTIVES

These are the following objectives:

1. To create a database for the Monitoring of the structure.
2. To use a finite element to determine the deformation of the structure.
3. To serve as a base study for the future observations and monitoring.

1.4. SCOPE OF THE PROJECT

The scope of this project exercise comprised the following operations;

1. Reconnaissance survey
2. Identification of deformation type
3. Conditions and environment
4. Monitoring techniques
5. Comprehensive report writing

1.5. JUSTIFICATION OF STUDY

The research demonstrates the use of Finite Element Analysis (FEA) for deformation monitoring in the university's Physics Department building. FEA enables proactive structural assessment, enhances monitoring strategies, and supports well-informed renovation decision-making by putting a strong emphasis on safety, precision, and early detection.

These projects advance research, comply with legal requirements, and improve the university's standing by showcasing its dedication to compliance, safety, and innovation. In the end, using FEA guarantees the academic building's structural integrity, reduces hazards, and encourages continuous academic activity.

The findings will contribute to the existing body of knowledge, while also serving as a reference for future academic research and practical implementations in the field of deformation monitoring.

CHAPTER TWO

LITERATURE REVIEW

2.1. Meaning of Deformation

Deformation refers to the change in shape or size of a material under the influence of external forces or temperature changes. This concept is fundamental to the study of materials and their behavior under various conditions. Deformation can be classified into two main types: elastic deformation (temporary) and plastic deformation (permanent). **(Callister & Rethwisch, 2018.)**

Deformation is the alteration or change in shape or size of a body due to the application of external forces. **(Hibbeler, 2016)**

(Goodno, & Gere, 2012) defined deformation as “The change in shape or size of a body due to the application of forces or changes in temperature.”

Deformation refers to the change in shape or size of a material when subjected to external forces. It encompasses both elastic and plastic behavior. **(Beer et al, 2014)**

2.2. Types of Deformation

There are but a handful of the various forms of deformation. The precise kind of deformation experienced is determined by the loading circumstances, environmental variables, and material characteristics. Understanding the deformation behavior of materials is crucial for efficient design and analysis of structures, components, and systems.

2.2.1. Elastic deformation:

1. In elastic deformation, the material returns to its original shape and size after the removal of the applied force or stress. The deformation is proportional to the applied stress, following Hooke's law, and the material remains within its elastic limit **(Gere & Goodno, 2012)**
2. "Elastic deformation is a temporary change in shape or size of a body under the action of applied forces. Upon removal of the forces, the body regains its original configuration." **(Gere & Goodno, 2012,).**

2.2.2. Plastic deformation:

Plastic deformation is a permanent change in the shape or size of a material that occurs when the applied stress exceeds the material's yield strength. During plastic deformation, the material undergoes irreversible changes in its internal structure, such as dislocation movement and grain boundary sliding, which result in a non-recoverable deformation even after the applied stress is removed. **(Callister,&Rethwisch,2021).**

2.2.3. Brittle deformation:

1. In brittle deformation, the material fails abruptly without significant plastic deformation, typically by fracture or cracking. Brittle materials, such as ceramics and some polymers, have little or no plastic deformation before failure. **(Ashby & Jones,2012).**

2. Brittle materials fail without significant plastic deformation. The fracture process is characterized by the formation and propagation of cracks, with little or no prior plastic deformation. **(Ashby & Jones, 2012,)**

2.2.4. Ductile deformation:

1. In ductile deformation, the material undergoes significant plastic deformation before failure, allowing for substantial elongation or change in shape. Ductile materials, such as metals, can undergo large plastic deformations without fracturing. **(Callister & Rethwisch 2018)**

2.2.5. Creep deformation:

1. Creep deformation occurs when a material is subjected to constant stress or load over an extended period, resulting in a time-dependent deformation. Creep deformation is commonly observed in materials at elevated temperatures and is an important consideration in high-temperature applications. **(Dowling, N. E. (2012).**
2. "Creep is a time-dependent deformation process that occurs in materials subjected to a sustained load or stress, especially at elevated temperatures. **(Dowling, 2012,)**

2.3. Deformation Monitoring;

Deformation monitoring is the systematic measurement and tracking of the alteration in the shape or dimensions of an object as a result of stress induced by applied loads. Deformation monitoring is a major component of logging measured values that may be used for further computation, deformation analysis, predictive maintenance and alarming.

The main purpose of structural deformation monitoring scheme and analysis is to detect any significant movements of the structure. **(Engr. Prof. Raphael Ehigiator-Irughe, 2018)**

According to **(Schrott & Geiß, 2018)** Deformation monitoring is the systematic measurement and tracking of changes in the shape and geometry of objects, structures, and natural surfaces over time.

(Mihail et al., 2017) also defines it as; Deformation monitoring is the process of determining changes in the geometry of structures, terrain, or other objects over time, using geodetic and geotechnical measurements and analysis techniques.

Deformation monitoring involves the periodic measurement and analysis of changes in the shape, position, and geometry of natural or man-made objects, such as buildings, bridges, dams, slopes, or landforms, over time." **(Huang et al., 2021)**. Similarly, **(Psimoulis et al., 2022)** also defines Deformation monitoring as "the periodic measurement and analysis of changes in the shape, position, or geometry of structures, terrain, or other objects of interest over time, typically using geodetic, geotechnical, or remote sensing techniques."

"Deformation monitoring is the systematic process of measuring and analyzing the spatial and temporal changes in the shape, position, or dimensions of structures, natural surfaces, or other objects, often in response to applied loads or environmental factors."
(Ghilardi et al., 2022)

2.4. Types of Deformation Monitoring:

Here are some recent definitions of different types of deformation monitoring:

2.4.1. Geodetic Deformation Monitoring: "Geodetic deformation monitoring involves the precise measurement and analysis of changes in the position, shape, or geometry of structures, terrain, or other objects over time, using various geodetic techniques such as global navigation satellite systems (GNSS), terrestrial surveying methods, and remote sensing technologies." **(Mukupa et al., 2023)**

2.4.2. Geotechnical Deformation Monitoring: "Geotechnical deformation monitoring is the process of measuring and analyzing changes in the shape, position, or dimensions of earth structures, such as slopes, embankments, and foundations, using various geotechnical instruments and techniques, including inclinometers, extensometers, and piezometers." **(Hu et al., 2023).**

2.4.3. Structural Deformation Monitoring: "Structural deformation monitoring involves the measurement and analysis of changes in the shape, position, or geometry of buildings, bridges, dams, and other engineered structures over time, using a combination of geodetic, geotechnical, and remote sensing techniques, such as terrestrial laser scanning, photogrammetry, and strain gauges." **(Zeng et al., 2023).**

2.4.4. Remote Sensing Deformation Monitoring: "Remote sensing deformation monitoring involves the use of satellite, airborne, or ground-based remote sensing technologies,

such as synthetic aperture radar (SAR), light detection and ranging (LiDAR), and photogrammetry, to measure and analyze changes in the shape, position, or geometry of structures, terrain, or other objects from a distance." (Crosetto et al., 2023).

2.4.5. Multi-sensor Deformation Monitoring: "Multi-sensor deformation monitoring combines different geodetic, geotechnical, and remote sensing techniques to measure and analyze deformations, leveraging the strengths of each technique and integrating the data through advanced data fusion and processing methods." (Luo et al., 2023).

2.5. Advantages of Deformation studies:

The following are some main benefits of deformation monitoring;

2.5.1. Early detection of structural or ground movements: Deformation monitoring enables the early detection of potentially hazardous movements in structures, slopes, or terrain, allowing for timely intervention and mitigation measures (Psimoulis et al., 2022).

2.5.2. Structural health assessment: By monitoring deformations, the structural health and integrity of buildings, bridges, dams, and other infrastructure can be assessed, facilitating maintenance planning and ensuring public safety (Zeng et al., 2023).

2.5.3 Risk mitigation and prevention of catastrophic failures: Deformation monitoring plays a crucial role in identifying potential risks and preventing catastrophic failures,

such as bridge collapses, dam breaches, or landslides, by providing early warning signs **(Crosetto et al., 2023)**.

2.5.4. Improved understanding of deformation mechanisms: Deformation monitoring data can help researchers and engineers better understand the underlying mechanisms and causes of deformations, leading to improved design and construction practices **(Hu et al., 2023)**.

2.5.5 Cost-effective maintenance and decision-making: By identifying areas requiring repair or reinforcement, deformation monitoring can facilitate cost-effective maintenance and informed decision-making, ultimately leading to cost savings in the long run **(Mukupa et al., 2023)**.

2.6. Data Analysis

In deformation research, data analysis is essential, and many methods are used for extracting useful information from the gathered data. The following are some of the various methods in analyzing data.

2.6.1. Point Cloud Analysis:

1. Point cloud comparison and registration techniques for detecting and quantifying deformations from terrestrial laser scanning (TLS) or LiDAR data **(Mukupa et al., 2023; Zeng et al., 2023)**.

2. Techniques like Iterative Closest Point (ICP), Normal Vectors, and Cloud-to-Cloud (C2C) for point cloud alignment and deformation analysis (**Scaioni et al., 2023; Palazzo et al., 2023**).

2.6.2 Time Series Analysis:

1. Statistical methods for analyzing time-series deformation data, including trend analysis, seasonality analysis, and change-point detection (**Crosetto et al., 2023; Psimoulis et al., 2022**)
2. Advanced techniques like Kalman filtering, Autoregressive Integrated Moving Average (ARIMA) models, and Holt-Winters methods for time-series forecasting and deformation prediction (**Hu et al., 2023; Luo et al., 2023**).

2.6.3 Finite Element Analysis (FEA):

Finite Element Analysis (FEA) is a powerful numerical technique widely used in deformation studies to simulate and analyze the behavior of structures and natural systems under various loading conditions and environmental factors. FEA involves dividing the structure or system into a finite number of smaller elements, each with specific material properties and boundary conditions. These elements are interconnected at nodes, forming a mesh that represents the overall geometry of the structure or system.

1. Structural analysis and deformation simulations: FEA models can be used to simulate the deformation behavior of structures, such as buildings, bridges, dams, and underground excavations, under various loading scenarios, including static,

dynamic, and environmental loads. Integration of deformation monitoring data with FEA models for structural analysis, stress-strain calculations, and deformation behavior simulations **(Zeng et al., 2023; Zhu et al., 2023)**.

2. Calibration and validation of FEA models using real-world deformation data **(Berberan et al., 2022; Ghilardi et al., 2022)**

2.6.4. Multi-Sensor Data Fusion:

1. Techniques for combining data from multiple sensors (e.g., GNSS, TLS, InSAR) to improve accuracy and reliability of deformation measurements **(Luo et al., 2023; Zhu et al., 2023)**.
2. Advanced data fusion methods, such as Kalman filtering, Bayesian inference, and machine learning algorithms **(Mukupa et al., 2023; Niu et al., 2022)**.

2.7. Modelling and Prediction

In deformation investigations, modeling and prediction are essential tools that help engineers and researchers comprehend the basic mechanisms, predict future behavior, and create practical mitigation plans, some examples are:

1. Numerical Modeling:
 - i. Finite Element Method (FEM) modeling for simulating deformations in structures and natural systems **(Zeng et al., 2023; Zhu et al., 2023)**.
 - ii. Discrete Element Method (DEM) modeling for analyzing deformations in granular materials and rock masses **(Huang et al., 2023; Yan et al., 2023)**.

iii. Boundary Element Method (BEM) modeling for analyzing deformations in elastic and inelastic media **(Beskos, 1997; Syngellakis, 2015)**.

2. Empirical Modeling:

i. Regression analysis and curve fitting techniques for developing empirical models based on deformation monitoring data **(Hu et al., 2023; Luo et al., 2023)**.

ii. Artificial Neural Networks (ANNs) and Support Vector Machines (SVMs) for data-driven modeling of deformation patterns and behavior **(Kitsakis et al., 2023; Zeng et al., 2023)**.

3. Hybrid and Ensemble Modeling:

i. Combination of multiple modeling techniques, such as physics-based and data-driven models, for improved accuracy and robustness **(Zhu et al., 2023; Mukupa et al., 2023)**.

ii. Ensemble methods, like bagging and boosting, for combining multiple models and improving predictive performance **(Crosetto et al., 2023; Kitsakis et al., 2023)**.

CHAPTER THREE

METHODOLOGY

This chapter describes the processes used to monitor the deformation of the **Physics department building**, it discusses the research design, tools for gathering data and methods for analyzing the data, and the approach for achieving the accuracy and dependability of the results.

3.1. STUDY LOCATION

The project site is the Physics Department which is located in the University of Benin main campus Ugbowo along Lagos road Benin city Edo state, Nigeria. It has a geographical coordinates as: latitude 6.399755°N , 5.615334°E and 6.399720°N , 5.615915° . Major facilities in my area of interest include: Physical science complex, Mathematics and Geology departments beside my study area and a field. The length of the stretch is $124.369\text{m}(0.12\text{km})$ as highlighted in the Figure 3.1.

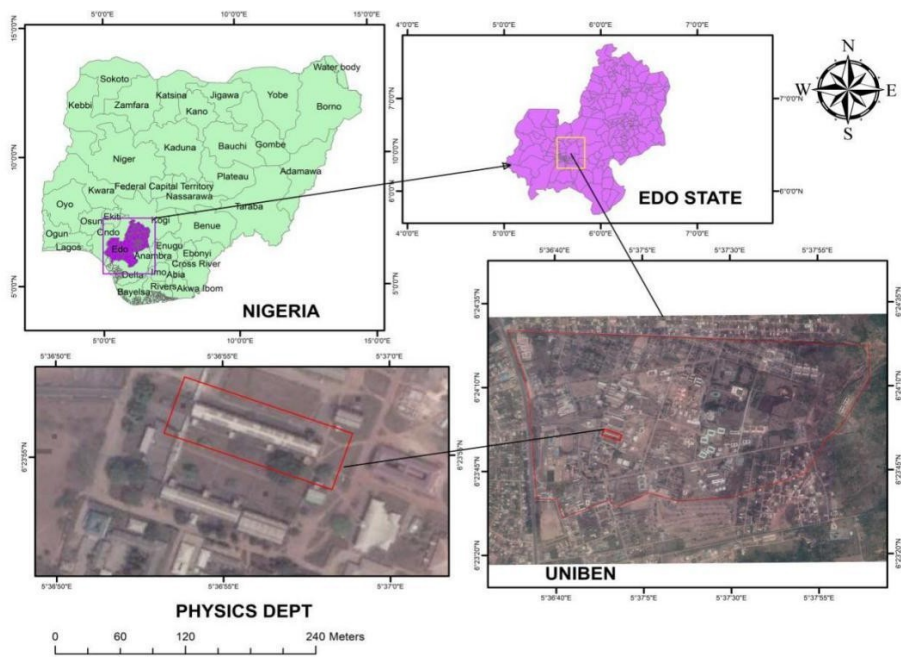

Figure 3.1: showing the study area

3.2. PROJECT PLANNING AND RECONNAISSANCE

The project procedure is shown in the flow chart below

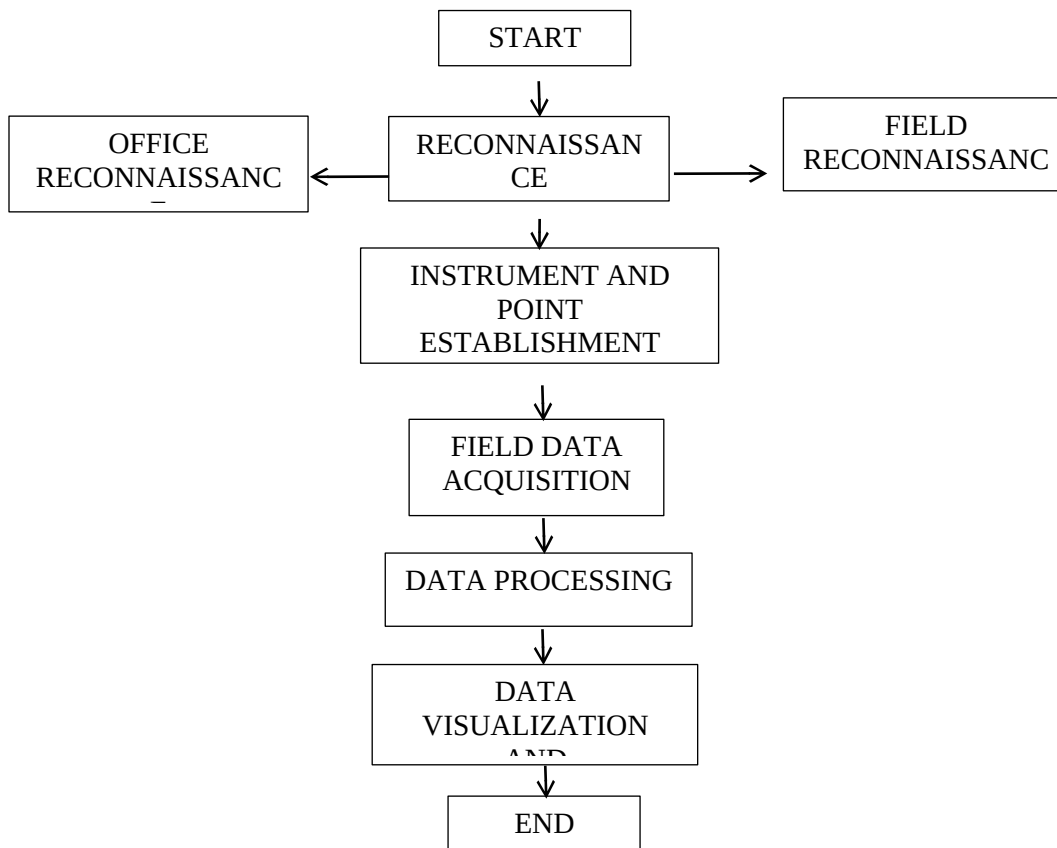

Figure 3.2 Flow chart of project procedures

3.2 .1. Project Planning

The success of any deformation survey depends on careful preparation and reconnaissance beforehand. This first phase is critical to building the survey's framework, facilitating efficient data collection, and guaranteeing that the study's goals are achieved. There were two stages to the project planning: Office Reconnaissance and Field Reconnaissance.

3.2.2. Office Reconnaissance

Any office-related initiative must have a deep awareness of the current environment to succeed. An essential first step in obtaining vital details about the physical surroundings and the spatial organization is the office reconnaissance phase. The main goals, techniques, and conclusions of the office reconnaissance carried out for the Department of Physics Building's Deformation monitoring are described in this section.

- (a) Determination of the location of the project area using google earth
- (b) Download of Satellite image of the project area
- (c) Collection of coordinates of the existing controls

After gathering the information, the next stage was:

3.2.3. FIELD RECONNAISSANCE

For the deformation monitoring project to be executed successfully, the field reconnaissance phase is essential. This phase entails a thorough on-site analysis of the study area's structural and geographical components. Assessing climatic conditions and comprehending the topography and geological features influencing deformation patterns are the goals of the field reconnaissance.

On getting to the site, after the structure was observed, we discovered that the pillars had moved out of their original position, (shifted from the beam) and there was a huge crack on the wall.

An on-site survey was carried out, the perimeter of the department building was then measured, at every 50m interval, a point was marked, this was done using a 50m steel tape, marker, and sticks, a total of 11 points were marked.

3.3. EQUIPMENTS AND INSTRUMENTS USED

Equipment and materials used while the field work was being carried out;

1. Tersus GNSS rover and staff
2. Permanent marker
3. Nuwa-Configured phone
4. Power bank (External Power Source)
5. 50meters tape

Software

Software application used for the project analysis include;

1. Arc Map
2. Microsoft word 2023 (Word, and Excel)
3. Notepad
4. Nuwa Application
5. Google Earth Pro

Hardware

- 1, Intel(R) Xeon(R) CPU E3-1505M v5 @ 2.80GHz
- 2, Installed memory (RAM): 16.00 GB
- 3, x86_64 based processor

3.3.1. DATA ACQUISITION

For better accuracy, we employed the use of the TERSUS GNSS, Tersus GNSS receivers are designed to acquire high-precision positioning data from satellite constellations such as GPS, GLONASS, BeiDou, and Galileo. Intermediate points along the structure were recorded at 50-meter intervals. To ensure accuracy, these points were interconnected, forming a series of triangles.

The coordinate system is projected to UTM ZONE 31 NIGERIA with the average latitude of 00.000000000N and a projection height of 0.0

The datum transformation is set to Bursa Parameters which is denoted and given as

Dx(m) -111.916000

Dy(m) -87852.000000

Dz(m) 114.49900

Rx(s) 1.87527000

Ry(s) 0.202140000

Rz(s) 0.21935000

Scale(ppm) 0.03245000000

The Ellipsoid is set to Clarke 1880 mod.

EMG08-25 is used for the geoid as the height fitting.

The phone is connected via bluetooth and also connected to Professor Ehigiators core station by clicking the rover icon in the nuwa app.

The survey is started by a click and then the points are taken

3.5 Creating a Data Base for Monitoring the Structure

There are various steps involved in creating a data base for monitoring the structure, from collecting and analyzing data to creating real-time data for instant data insights. The

following section shows the process of creating a database for structure monitoring, including data collection, analysis, and visualization.

3.5.1 Data Collection and Analysis

The first step in creating a database for structure monitoring is to collect and analyze data. This involves defining what data to collect, selecting and training observers, conducting observations at appropriate times, and recording data in agreed ways.

The data collected is organized in a way that is appropriate for the intended use and transformed into quantitative data when possible. Once the data is collected, it should be analyzed to identify trends and patterns. This involves performing mathematical operations, such as calculating for the distance and bearing, or identifying the stiffness of the structure.

The analysis is conducted in a transparent and reproducible way, with clear documentation of the methods used and the assumptions made.

3.5.2 Using Finite Element to determine the Deformation of the Structure

The finite element approach involves simplifying complex systems by breaking them into smaller, more manageable units. It is commonly used to solve partial differential equations in two or three spatial dimensions, particularly in boundary value problems, through computational techniques. The Finite Element Method (FEM) achieves this by segmenting the system into finite elements, facilitated by generating a mesh structure and applying an algorithm to efficiently divide the space. This mesh, composed of discrete points, defines the

numerical domain for the solution. In addressing boundary value problems, FEM produces a set of algebraic equations that approximate the unknown function throughout the domain. These equations, representing individual elements, are then combined to form a comprehensive system that accurately models the entire problem. By minimizing an associated error function using the calculus of variations, FEM provides an approximate solution. This process involves mathematical computations, such as distance and bearing evaluations or assessing structural stiffness. The analysis is conducted with transparency and reproducibility, supported by detailed documentation of the methodologies and assumptions applied. Further insights into the practical use of FEM include its application in analyzing structural deformations.

CHAPTER FOUR

Result and Discussion

4.1 Results

Deformation monitoring using GNSS involves the collection of high-precision position data from satellites to track changes in the Earth's surface over time. This technique offers unparalleled accuracy and reliability, making it indispensable in a wide range of industries, including geology, civil engineering, and infrastructure management.

Field data acquisition typically involves the deployment of GNSS receivers at strategic locations across the area of interest. These receivers continuously track signals from multiple satellites, allowing for the calculation of precise 3D coordinates. By comparing these coordinates over time, analysts can detect even subtle deformations in the monitored area, such as subsidence, uplift, or lateral movement.

Several studies have demonstrated the effectiveness of GNSS in deformation monitoring. For example, research by Sładek Sładeczek, & Jędrysiak, J. (2023) showcased the use of GNSS-based interferometric synthetic aperture radar (InSAR) for monitoring ground subsidence with millimeter-level accuracy. Similarly, the work of Xu, Zhuang, & Yu, (2023) highlighted the utility of GNSS in detecting tectonic plate movements and seismic activity. The tables below shows the different data set for the weeks monitored.

WEEK 1
DAY 1

Pt No	Northing	Eastings	Height
Pt A	708078,5399	789418.3798	167.2492
Pt B	708118.7248	789304.7568	168.3008
Pt C	708137.4274	789309.7724	167.3914
Pt D	708096.7590	7894424. 8422	167.3898

DAY 2

Pt NO	Northing	Easting	Height
Pt A	708078.5725	789418.3337	167.3322
Pt B	7088118.7779	789304.5939	168.6772
Pt C	708137.5112	789309.7491	167.3900
Pt D	708096.7390	789424.8098	167.4128

DAY 3

Pt No	Northings	Eastings	Height
Pt A	708078.5879	789418.3431	167.2980
Pt B	708118.5412	789304.6911	167.8330
Pt C	708137.4540	789309.7673	167.4230
Pt D	708096.8305	789424.8574	167.2586

DAY 4

Pt No	Northings	Eastings	Height
Pt A	708078.6238	789418.2492	167.2596
Pt B	708118.7601	789304.6958	167.5226
Pt C	708138.5659	789310.8936	168.7222
Pt D	708096.6724	789424.7392	167.5408

DAY 5

Pt No	Northings	Eastings	Height
Pt A	708078.6117	789418.3367	167.2750
Pt B	708118.7229	789304.7053	167.4420
Pt C	708137.5743	789309.6701	167.2568
Pt D	708096.7454	789427.8109	167.3234

WEEK 2

DAY 1

Pt No	Northing	Eastings	Height
Pt A	708078.5659	789418.3610	167.5858
Pt B	708118.4860	789304.7073	167.0370
Pt C	708137.6068	789309.7957	168.2600
Pt D	708096.7839	789424.7517	167.3234

DAY 2

Pt No	Northing	Eastings	Height
Pt A	708078.5229	789418.4500	167.2748
Pt B	708118.7446	789304.7117	167.4284
Pt C	708137.4345	789309.8400	167.3788
Pt D	708096.7014	789424.7404	167.3352

DAY 3

Pt No	Northing	Eastings	Height
Pt A	708078.4123	789418.3809	167.1954
Pt B	708118.7394	789304.6800	167.3498
Pt C	708137.7635	789330.8301	167.4720
Pt D	708096.8362	789424.8102	167.2996

DAY 4

Pt No	Northing	Eastings	Height
Pt A	708078.4965	789418.4107	167.3138
Pt B	708118.5808	789304.6463	167.5432
Pt C	708137.5214	789310.0109	167.4030
Pt D	708096.6056	789424.9239	167.3784

DAY 5

Pt No	Northing	Eastings	Height
Pt A	708078.5435	789418.5356	167.3138
Pt B	708118.5858	789304.6514	167.5432
Pt C	708137.5214	789309.9355	167.3788
Pt D	708096.6056	789424.8345	167.3784

Table 4: Showing data collected

4.2 Data Processing and Analysis

The process of monitoring a structure such as dams, reservoir, bridges, buildings, etc using GIS involves collecting and analyzing various and finding different parameters such as the stiffness matrix(K), the distance(l) and the bearing(θ). The parameters contribute greatly to the deformation monitoring analysis on the structure. This process of data analysis involves extracting meaningful information from the collected observations. Data fusion of GNSS data with other geodetic and geophysical datasets to enhance deformation monitoring capabilities. (Kitsakis, Kougioumtzis, & Kapetanidis 2023) Figure 4.2 below represents the section of the building whose deformation status is being considered.

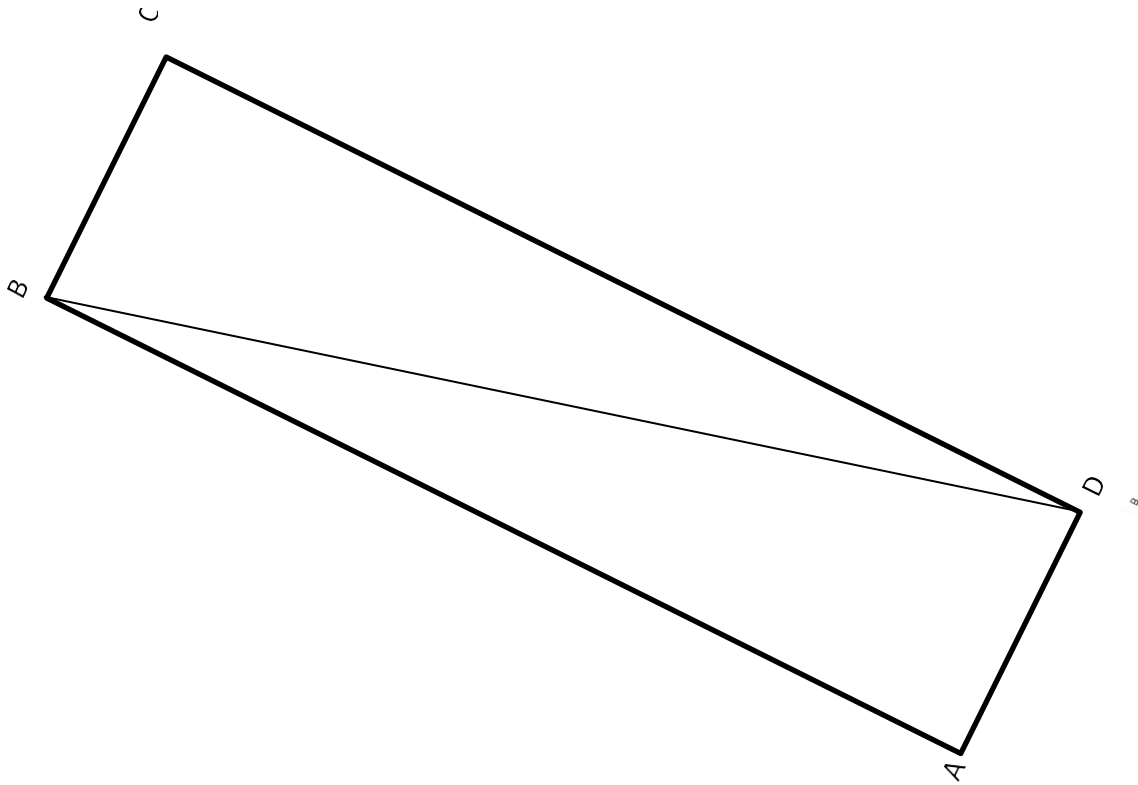
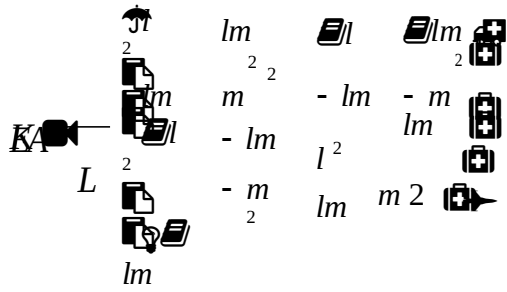

Figure 4.2: Showing the building's cross section

4.2.3 Determination of the Stiffness Matrix of the Elements

The fundamental attributes of a finite element are encapsulated within its stiffness matrix. In the case of a structural finite element, this matrix encompasses both geometric and material properties, providing insight into the element's resistance to deformation under loading. Such deformation can involve axial, bending, shear, and torsional effects (Ehigiator & Irughe, 2019). For finite elements employed in nonstructural analyses like fluid flow and heat transfer, the term "stiffness matrix" is still utilized as it signifies the element's resistance to alteration when subjected to external influences. The equation for the local stiffness matrix is presented in the equation below:



Equation 4.1

$$L = \sqrt{N^2 + E^2}$$

Equation 4.2

WEEK 1

Northings		Eastings	
A	708078.5872	A	789418.3285
B	7080118.705	B	789304.6886
C	708137.7066	C	789309.9705
D	708096.7493	D	789424.8119

Table 4.2.1 showing the average Eastings and Northings for week one

WEEK 2

Northings		Eastings	
A	708078.5082	A	789418.3285
B	708118.6273	B	789304.6793
C	708137.5619	C	789309.6424
D	708096.7027	D	78424.8121

Table 4.2.2 Showing the average Easting and Northings for week two

For Week 1

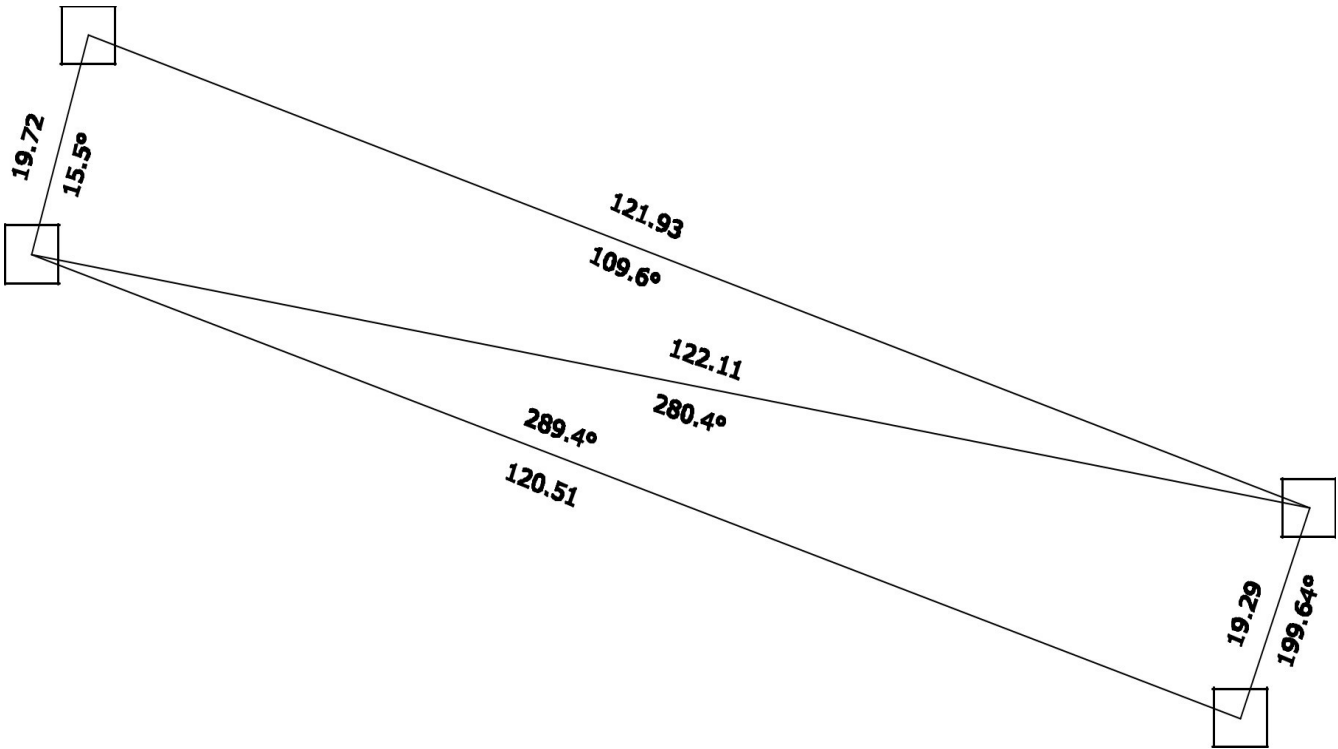
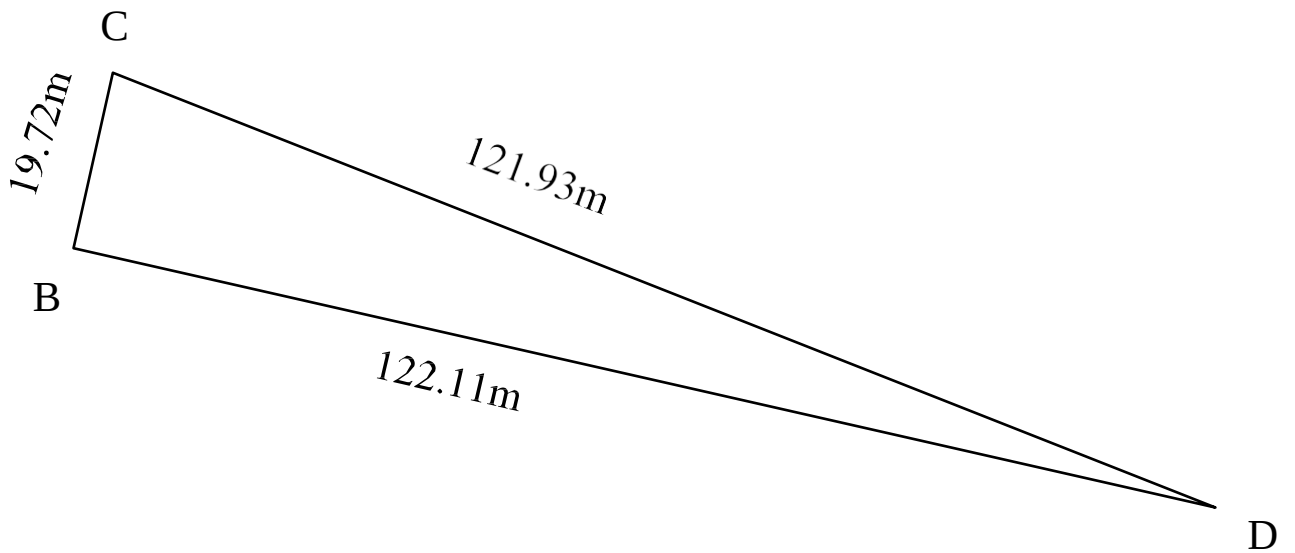

Figure 4.3: Showing the Distance and bearing for data collected in week one



$$\text{Area} = 1199.228 \text{ m}^2$$

$$L_1 = L \cos \theta$$

Equation 4.3.1

$$M_1 = L \sin \theta$$

Equation 4.3.2

$$L_1 = 19.72 \cos(15.5)$$

$$L_1 = 19.00$$

$$M_1 = 19.72 \sin(15.5)$$

$$M_1 = 5.27$$

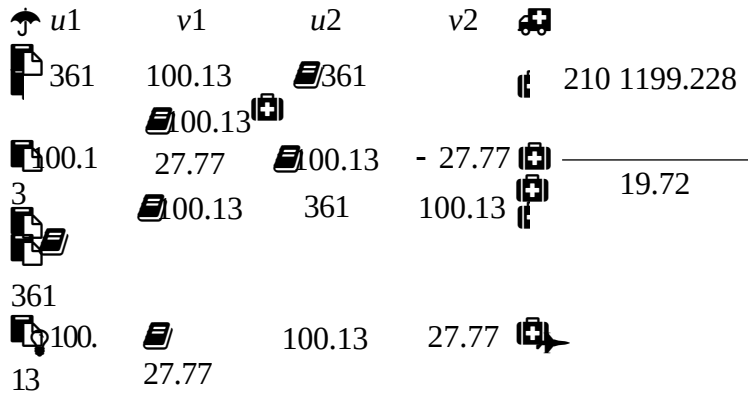
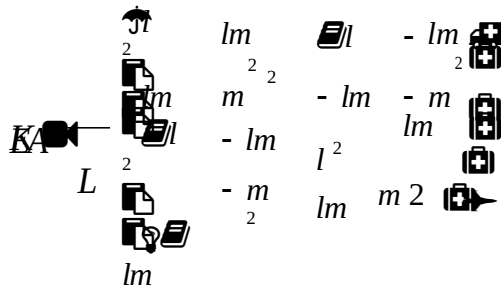

$$L_2 = L \cos \theta$$













$$L_2 = 121.93 \cos(109.6)$$

$$L_2 = -40.9$$

$$m_2 = L \sin \theta$$

$$m_2 = 121.93 \sin(109.6)$$

$$m_2 = 114.9$$

 u_2	v_2	u_3	v_3	
 1672.8	 4699.41	 1672.8	 4699.41	210 1199.228
			 4699.41	
 4699.41	13202.01	4699.41	 13202.01	<hr/> 121.93
 1672.8	4699.41	1672.8	 4699.41	
 4699.41	 4202.01	4699.41	13202.01	
4699.41				

$$L_3 = L \cos \theta$$













$$L_3 = 122.11 \cos(280.4)$$

$$L_3 = 22.04$$

$$m_3 = L \sin \theta$$

$$m_3 = 122.11 \sin(280.4)$$

$$m_3 = -120.10$$

 u_3	v_3	u_4	v_4	
 485.76	 2647.0	 2647.0	4699.41	210 1199.228
 2647.0	14424.01		 13202.01	
 485.76	2647.0	485.76	 2647.0	<hr/> 122.11
 485.76			 4699.41	
 2647.0	 4424.01	4699.41	13202.01	

Global Matrix

	u_1	v_1	u_2	v_2	u_3	v_3	u_4	v_4
u_1	361	100.13	-361	-100.13	0	0	0	0
v_1	100.13	27.77	-100.13	-27.77	0	0	0	0
u_2	-361	-100.13	167497.46	130502.62	-1672.8	4699.41	0	0
v_2	-100.13	-27.77	100.13	366619.81	4699.41	-13202.01	0	0
u_3	0	0	-1672.8	4699.41	2282785.402	34945720.47	-485.76	2647.0
v_3	0	0	4699.41	-13202.01	12439338.27	190425924.3	2647.0	-14424.01
u_4	0	0	0	0	-485.76	2647.0	2647.0	-14424.01
v_4	0	0	0	0	2647.0	-14424.01	-2647.0	14424.01

Define the 8x8 matrix

```
A = [361, 100.13, -361, -100.13, 0, 0, 0, 0;
      100.13, 27.77, -100.13, -27.77, 0, 0, 0, 0;
      -361, -100.13, -167497.46, 130502.62, -1672.8, 4699.41, 0, 0;
      100.13, -27.77, 100.13, 366619.81, 4699.41, -13202.01, 0, 0;
      0, 0, -1672.8, 4699.41, 2282785.402, 34945720.47, -485.76, 2647.0;
      0, 0, 4699.41, -13202.01, 12439338.27, 190425924.3, 2647.0, -14424.01;
      0, 0, 0, 0, -485.76, 2647.0, 2647.0, -14424.01;
      0, 0, 0, 0, 2647.0, -14424.01, -2647.0, 14424.01];
```

Define the equations B and C

$B = (210 * 1199.228 / 263.76)^{-1}$; Calculate B

$C = (54.069 * 10^3)$; Calculate C

Multiply matrix A by B and C together

$Result3 = A * B * C$; Matrix A multiplied by scalars B and

C Reshape the result into a single column vector

$Result_column = result3(;$

Display the results as a single column

Disp('The result of multiplying matrix A by B and C as a single column is:');

Disp(result_column);

The result of multiplying matrix A by B and C as a single column is:

```

0      0      0      0      0      0      0      0
0      0      0      0      0      0      0      0
0      0 -0.0009  0.0007      0      0      0      0
0      0      0  0.0021      0 -0.0001      0      0
0      0      0      0  0.0129  0.1979      0      0
0      0      0 -0.0001  0.0704 -1.0784      0 -0.0001
0      0      0      0      0      0      0 -0.0001
0      0      0      0      0 -0.0001      0  0.0001

```

```

0= U1
0= V1
-0.0001= U2
0.000667= V2
0.1054= U3
-0.504= V3
-0.00005= U4
0= V4

```

Triangle BCD WEEK 1		Triangle BCD WEEK 2		DISPLACEMENT
U1=	0	U1=	0.11725	0.058625
V1=	0	V1=	-0.44735	-0.223675
U2=	-0.0001	U2=	0	-0.00005
V2=	0.000667	V2=	0	0.000333333
U3=	0.1054	U3=	0	0.0527
V3=	-0.504	V3=	0	-0.252
U4=	-0.00005	U4=	0	-0.000025
V4=	0	V4=	0	0

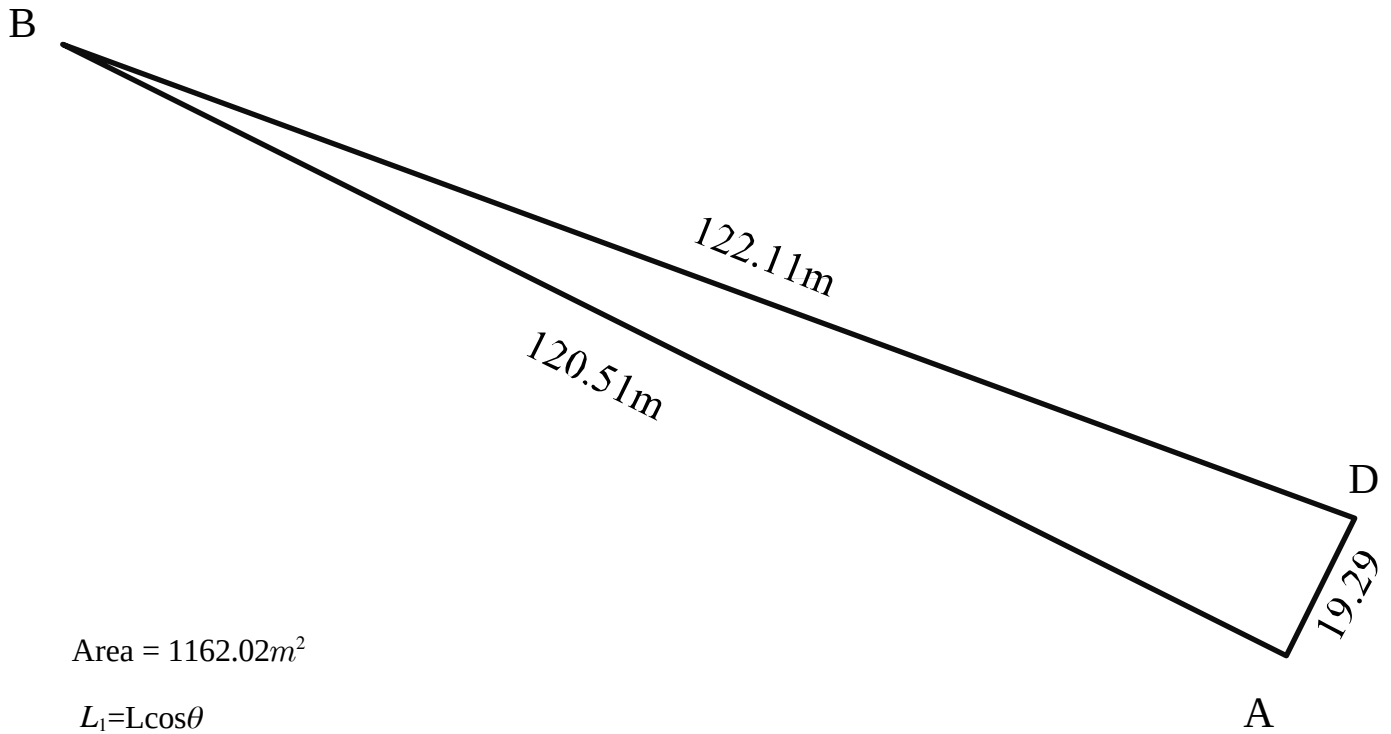

Area = 1162.02m²

$L_1 = L \cos \theta$

$M_1 = L \sin \theta$

$L_1 = 122.11 \cos(280.4)$

$L_1 = 22.04$

$M_1 = 122.11 \sin(280.4)$

$M_1 = 120.10$

u_3	v_3	u_4	v_4
485.76	2647.0	485.76	4699.41
2647.0	14424.01	2647.0	13202.01
485.76	2647.0	485.76	2647.0
2647.0	14424.01	4699.41	13202.01

210 1199.228
122.11

$L_2 = L \cos \theta$

















$$L_2 = 19.29\cos(199.64)$$

$$L_2 = -18.17$$

$$m_2 = L \sin \theta$$

$$m_2 = 19.29\sin(199.64)$$

$$m_2 = -6.48$$

 u2	v2	u3	v3	
330.15	117.74		 117.74	
 117.74	41.99	330.15	 41.99	
	 17.74	 17.74	330.15	
330.15		330.15	330.15	
 17.		 17.74	41.99	
74	41.99			

$$\frac{210 \ 1162.02 \ 1}{19.62}$$

$$L_3 = L \cos \theta$$





















$$L_3 = 120.51\cos(289.4)$$

$$L_3 = 40.03$$

$$m_3 = L \sin \theta$$

$$m_3 = 120.51\sin(289.4)$$

$$m_3 = -113.67$$

 u3	v3	u4	v4	
1602.40	 4550.21	 1602.40	4550.21	
	12920.87		 292087	
4550.21	4550.21	4550.21		
 1603.4	 2920.87	1602.40		
0				
		4550.21	4550.21	
4550.21			12920.87	

$$\frac{210 \ 1162.02 \ 1}{120.51}$$

Global Matrix

u_1	v_1	u_2	v_2	u_3	v_3	u_4	v_4
485.76	264.7	485.76	264.7	0	0	0	0
264.7	14424.01	264.7	14424.01	0	0	0	0
485.67	264.7	873907.05	1698282.937	330.15	177.74	0	0
264.7	14424.01	311657.78	605664.18	117.74	41.99	0	0
0	0	330.15	117.74	188666.516	191063.32	1602.40	4550.21
0	0	117.74	41.99	4550.21	12920.87	4550.21	12920.87
0	0	0	0	1602.40	4550.21	4550.21	12920.87
0	0	0	0	12920.87	14424.01	4550.21	12920.87

Define the 8x8 matrix A

```
A = [485.76, -2647, -485.76, 2647, 0, 0, 0, 0;
-2647, 14424.01, 2647, -14424.01, 0, 0, 0, 0;
-485.67, 2647, 873907.05, -1698282.937, -33095, -177.74, 0, 0;
2647, -14424.01, -311657.78, 605664.18, -117.74, -41.99, 0, 0;
0, 0, -330.15, -117.74, -188666.576, 191063.32, -1602.40, 4550.21;
0, 0, -117.74, -41.99, -4550.21, 12920.87, 4550.21, -12920.87;
0, 0, 0, 0, -1602.40, 4550.21, 4550.21, -12920.87;
0, 0, 0, 0, -4550.21, -12920.87, -4550.22, 12920.87];
```

Define the equation B and C

```
B = (210 * 1191.740 / 262.25)^-1; % Calculate B (Inverse of 210 * 1191.740 / 262.25)
```

```
C = (54.069 * 10^3);          Calculate C
```

Multiply matrix A by B and C together

```
Result3 = A * B * C;          Matrix A multiplied by scalar B and
```

C Reshape the result to a single column vector

```
Result_column = result3;
```

```
Display the results as a single column
```

```
Disp('The result of multiplying matrix A by B and C as a single column is:');
```

```
Disp(result_column);
```

```
The result of multiplying matrix A by B and C as a single column is:
```

```
-0.015  -0.0028   0.015      0      0      0      0      0
0.0817   0.015  -0.0817      0      0      0      0      0
  0.015  -4.9514  -9.6222  -0.1875  -0.001      0      0      0
-0.0817  -1.7658  -3.4316  -0.0007  -0.0002      0      0      0
      0  -0.0019  -0.0007  -1.069   1.0825  -0.0091   0.0258   0.0258
      0  -0.0007  -0.0002  -0.0258   0.0732   0.0258  -0.0732  -0.0732
      0      0      0  -0.0091   0.0258   0.0258  -0.0732  -0.0732
      0      0      0  -0.0258  -0.0732  -0.0258   0.0732   0.0732
```

```
-0.00093= U1
  0.005=  V1
-2.94942= U2
 -1.056=  V2
0.007629= U3
-0.01059= V3
-0.02078= U4
  0.00432= V4
```

	Triangle BDA Week 1		Triangle BDA week 2	Displacement
U1=	-0.000933333	U1=	-1.00885	-0.504891667
V1=	0.005	V1=	-0.1932	-0.0941
U2=	-2.94942	U2=	0	-1.47471
V2=	-1.056	V2=	0	-0.528
U3=	0.007628571	U3=	0	0.003814286
V3=	-0.010585714	V3=	0	-0.005292857
U4=	-0.02078	U4=	-0.43315	-0.226965
V4=	0.00432	V4=	-0.149475	-0.0725775

WEEK 2

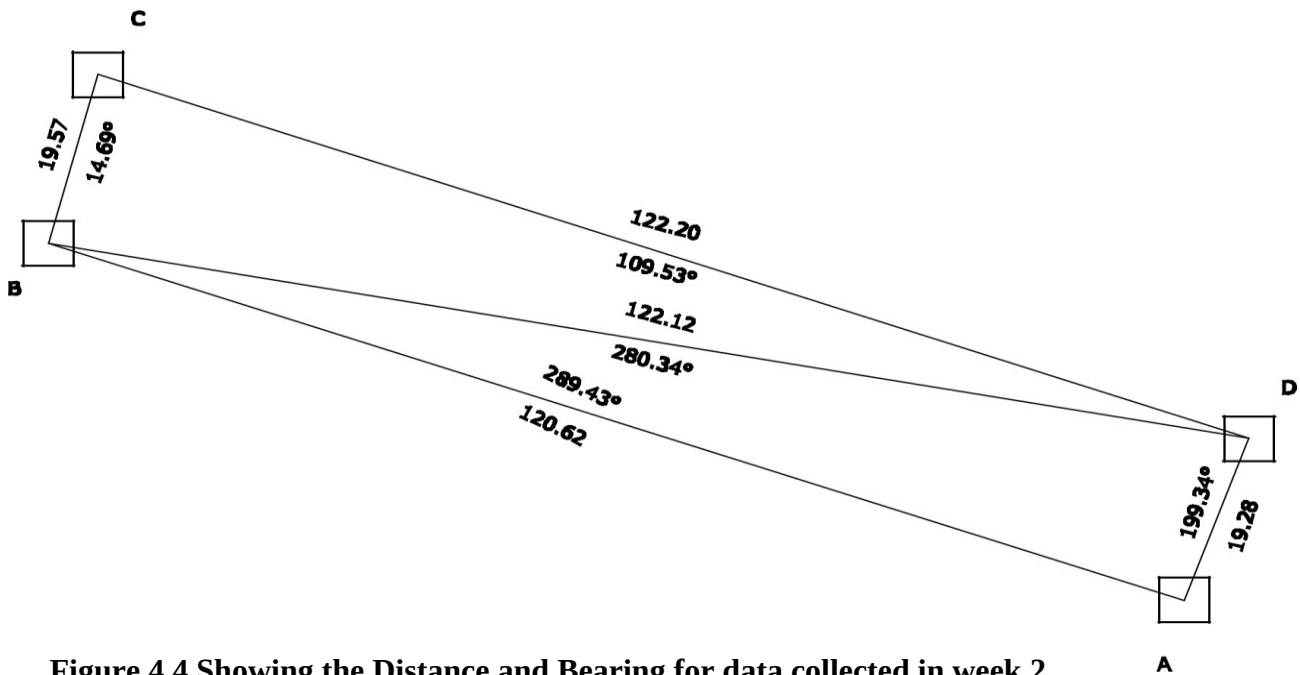
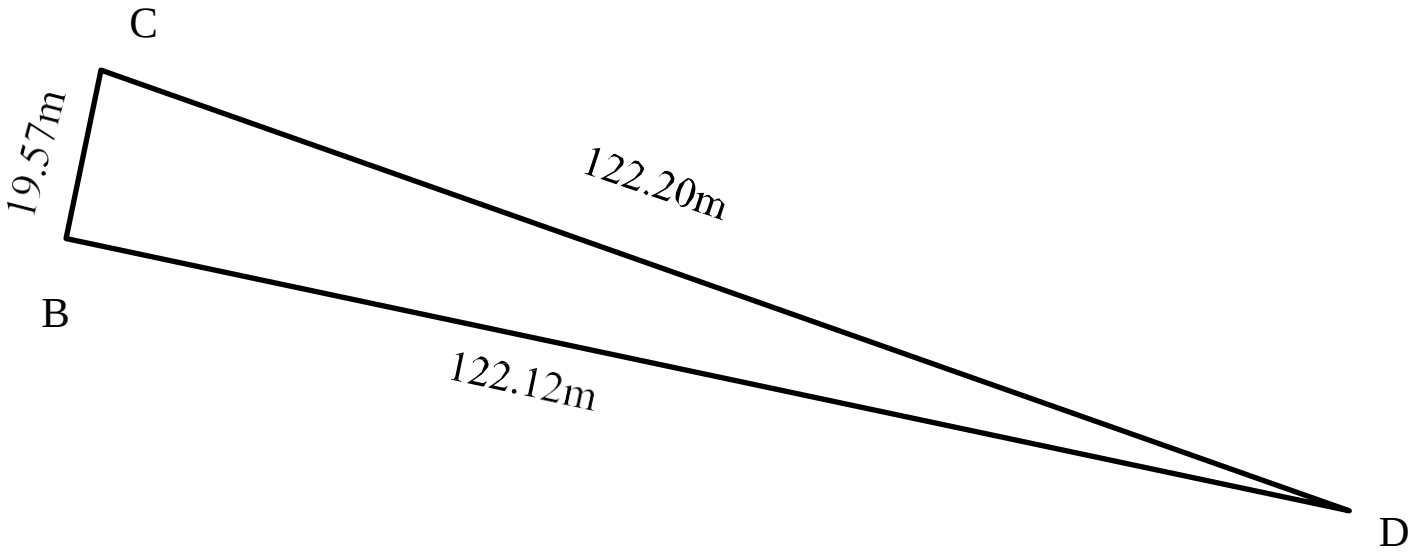

Figure 4.4 Showing the Distance and Bearing for data collected in week 2



Area= 1191.740m²

$L_1 = L \cos \theta$

$M_1 = L \sin \theta$

$L_1 = 19.57 \cos(14.69)$



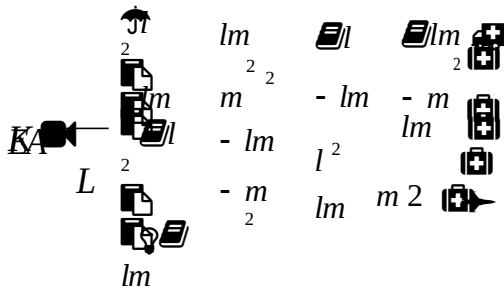

$L_1 = 18.93$

$M_1 = 19.57 \sin(14.69)$

$M_1 = 4.96$



	v_1	u_2	v_2	
u_1	93.89		93.89	210
358.34	358.34			1191.740
93.89	24.60		1.292087	
	93.89			

	- 93.89	358.34	93.89	19.57
358.34	- 24.60	93.89		
			24.60	
93.89				

$$L_2 = L \cos \theta$$

















$$L_2 = 122.2 \cos\{109.53\}$$

$$L_2 = -40.85$$

$$m_2 = L \sin \theta$$

$$m_2 = 121.20 \sin\{109.53\}$$

$$m_2 = 115.17$$

 u2	v2	u3	v3	
 1668.72	 4704.69	 1668.72	4704.69	 210 1191.740
				
 4704.69	13264.13	4704.69	 3264.13	 122.20
 1668.7	4704.69	1668.72	- 4704.69	
 1668.7	 3264.13	- 4704.69	13264.13	
2				
				
4704.79				

$$L_3 = L \cos \theta$$

















$$L_3 = 122.12 \cos\{280.84\}$$

$$L_3 = -22.97$$

$$m_3 = L \sin \theta$$

$$m_3 = 122.12 \sin\{280.84\}$$

$$m_3 = -119.94$$

 u3	v3	u4	v4	
 527.62	 2755.02	 527.62	2755.02	 210 1191.740
 2755.02	14385.60	2755.02	 4385.60	
 527.62	2755.02	527.62	 2755.02	 122.12
 2755.02	 4385.60	 2755.02	14385.60	

Global Matrix

	u_1	v_1	u_2	v_2	u_3	v_3	u_4	v_4
u_1	358.34	93.89	-358.34	93.89	0	0	0	0
v_1	93.89	24.60	-93.89	24.60	0	0	0	0
u_2	-358.34	-93.89	156676.12	115735.37	-1668.72	4704.69	0	0
v_2	-93.89	-24.60	-441723.34	326297.60	4704.69	-13264.13	0	0
u_3	0	0	-1668.72	4704.69	2482288.54	36542943.43	-527.62	2755.02
v_3	0	0	4704.69	-13264.13	12961515.04	190812468.5	2755.02	-14385.60
u_4	0	0	0	0	-527.62	2755.02	2755.02	2755.02
v_4	0	0	0	0	2755.02	-14385.60	-2755.02	14385.60

Define the 8x8 matrix A

```
A = [358.34 93.89 -358.34 -93.89 0 0 0 0; 93.89 24.60 -93.89 -24.60 0 0 0 0; -358.34 -93.89 -156676.12 115735.37 -1668.72 4704.69 0 0; -93.89 -24.60 -441723.34 326297.60 4704.69 -13264.13 0 0; 0 0 -1668.72 4704.69 2482288.54 36542943.43 -527.62 2755.02; 0 0 4704.69 -13264.13 12961515.04 190812468.5 2755.02 -14385.60; 0 0 0 0 -527.62 2755.02 2755.02 2755.02; 0 0 0 0 2755.02 -14385.60 -2755.02 14385.60];
```

Define the scalar values B and C

```
B = (210 * 1191.740 / 263.25); Calculate B
```

```
C = (54.069 * 10^3); Calculate C
```

Perform the calculation $(A * B)^{-1} * C$

```
Result3 = inv(A * B) * C;
```

Reshape the result to a single column vector

```
Result_column = result3(
```

Display the result as a single column

```
Disp('The result of  $(A * B)^{-1} * C$  as a single column is:');
```

```
Disp(result_column);
```

The result of $(A * B)^{-1} * C$ as a single column is:

-0.0832	0.3177	0	0	0	0	0	0	0.11725
0.3177	-1.2124	0	0	0	0	0	0	-0.44735
0	0	0	0	0	0	0	0	0
0	0	0	0	0	0	0	0	0
0	0	0	0	0	0	0	0	0
0	0	0	0	0	0	0	0	0
0	0	0	0	0	0	0	0	0
0	0	0	0	0	0	0	0	0

0.11725= U1
 -0.44735= V1
 0= U2
 0= V2
 0= U3
 0= V3
 0= U4
 0= V4

Triangle BCD WEEK 1		Triangle BCD WEEK 2		DISPLACEMENT
U1=	0	U1=	0.11725	0.058625
V1=	0	V1=	-0.44735	-0.223675
U2=	-0.0001	U2=	0	-0.00005
V2=	0.000667	V2=	0	0.0003333333
U3=	0.1054	U3=	0	0.0527
V3=	-0.504	V3=	0	-0.252
U4=	-0.00005	U4=	0	-0.000025
V4=	0	V4=	0	0

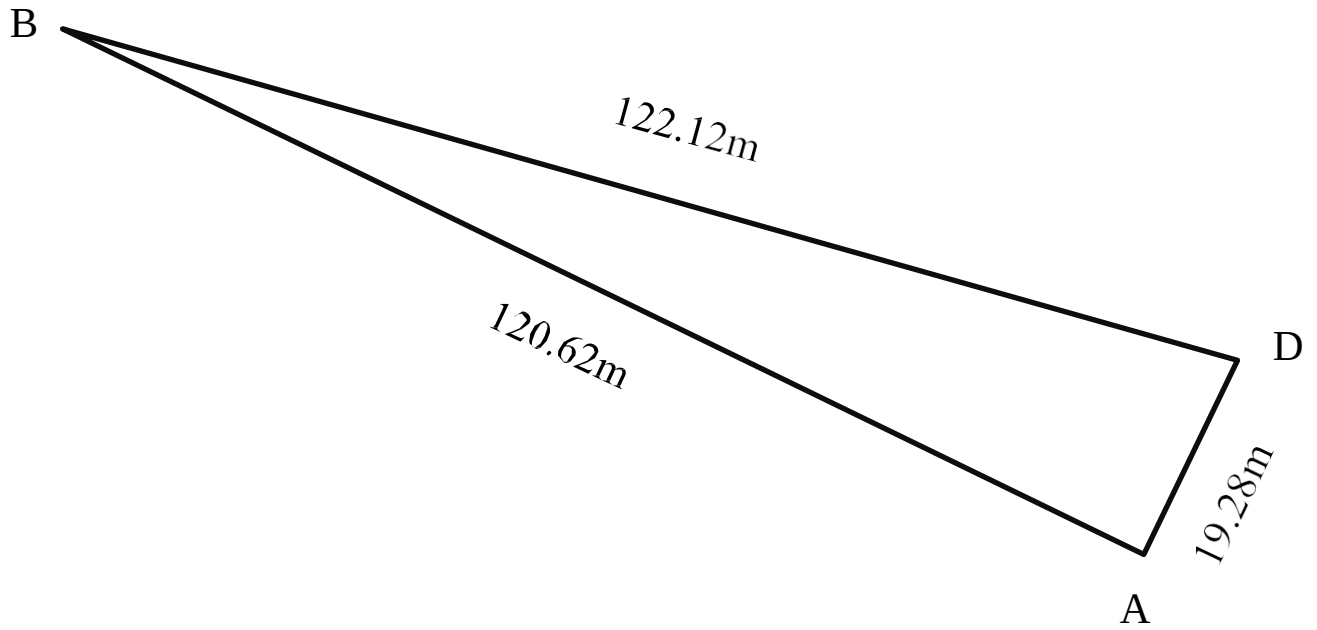

Area = 1162.867m²

$L_1 = L \cos \theta$

$M_1 = L \sin \theta$

$L_1 = 122.12 \cos(280.84)$

$L_1 = 22.97$

$M_1 = 122.12 \sin(280.84)$

$M_1 = -119.94$

u1	v1	u2	y2	
527.62	2755.02	527.62	2755.02	210 1162.867
2755.02	275	14385.60	2755.02	14385.60
527.62	5.02	2755.02	527.62	2755.02
		14385.6	2755.02	14385.60
		0		



122.12

$$L_2 = L \cos \theta$$

















$$L_2 = 19.28 \cos\{199.34\}$$

$$L_2 = -18.19$$

$$m_2 = L \sin \theta$$

$$m_2 = 19.28 \sin\{199.34\}$$

$$m_2 = -6.39$$

 u2	v2	u3	v3	
 330.88	116.23		 16.23	
 116.23	40.83	330.88	 40.83	
	 16.23	 16.23		
330.88		330.88	116.23	
 16.23		116.23	40.83	
23	40.83			

				210 1162.867
				19.28

















$$L_3 = L \cos \theta$$

$$L_3 = 122.12 \cos\{280.84\}$$

$$L_3 = 22.97$$

$$m_3 = L \sin \theta$$

$$m_3 = 122.12 \sin\{280.84\}$$

 u3	v3	u4	v4	
 1609.61	 4563.65	 609.61	4563.65	
	12939.06	4563.65	 2939.06	
4563.65	4563.65	1609.61	 4563.65	
 1609.6	 2939.06		12939.06	
1		4563.65		
				
4563.65				

				210 1162.867
				120.62

Global Matrix

	u_1	v_1	u_2	v_2	u_3	v_3	u_4	v_4
	527.62	2755.02	527.62	2755.02	0	0	0	0
	2755.02	14385.60	2755.02	14385.60	0	0	0	0
	527.62	2755.02	911581.02	1672097.27	330.88	16.2341	0	0
	2755.02	14385.60	320227.27	587364.05	16.2341	40.83	0	0
	0	0	330.88	16.2341	87091.57	186333.83	609.61	4563.65
	0	0	16.2341	40.83	530451.75	528301.82	4563.65	2939.06
	0	0	0	0	609.61	4563.65	4563.65	2939.06
	0	0	0	0	4563.65	2939.06	4563.65	12939.06

Define the 8x8 matrix A

```
A = [527.62 -2755.02 -527.62 2755.02 0 0 0 0; -2755.02 14385.60 2755.02 -14385.60 0 0 0 0; -527.62 2755.02 911581.02 -1672097.27 -330.88 -116.2341 0 0; 2755.02 -14385.02 -320227.27 587364.05 -116.2341 -40.83 0 0; 0 0 -330.88 -116.2341 -187091.57 186333.83 -1609.61 4563.65; 0 0 -116.2341 -40.83 -530451.75 528301.82 4563.65 -12939.06; 0 0 0 0 -1609.61 4563.65 4563.65 -12939.06; 0 0 0 0 4563.65 -12939.06 -4563.65 12939.06];
```

Define the scalar values B and C

```
B = (210 * 1162.867 / 262.02); Calculate B
```

```
C = (54.069 * 10^3); Calculate C
```

Perform the calculation $(A * B)^{-1} * C$

```
Result3 = inv(A * B) * C;
```

Reshape the result to a single column vector

```
Result_column = result3;
```

Display the result as a single column

```
Disp('The result of  $(A * B)^{-1} * C$  as a single column is:');
```

```
Disp(result_column);
```

The result of $(A * B)^{-1} * C$ as a single column is:

```

-1.6934  -0.3243      0      0      0      0      0      0
-0.3243  -0.0621      0      0      0      0      0      0
      0      0      0      0      0      0      0      0
      0      0      0      0      0      0      0      0
      0      0      0      0      0      0      0      0
      0      0      0      0      0      0      0      0
-2.8826  -0.5603  -0.0031  -0.0089  0.1231  -0.045  -0.0375  -0.0509
-1.0167  -0.1976  -0.0011  -0.0031  0.0434  -0.0159  0.0132  -0.018

```

```

-1.00885= U1
-0.1932= V1
      0= U2
      0= V2
      0= U3
      0= V3
-0.43315= U4
-0.14948= V4

```

	Triangle BAD Week 1		Triangle BAD week 2	Displacement
U1=	-0.000933333	U1=	-1.00885	-0.504891667
V1=	0.005	V1=	-0.1932	-0.0941
U2=	-2.94942	U2=	0	-1.47471
V2=	-1.056	V2=	0	-0.528
U3=	0.007628571	U3=	0	0.003814286
V3=	-0.010585714	V3=	0	-0.005292857
U4=	-0.02078	U4=	-0.43315	-0.226965
V4=	0.00432	V4=	-0.149475	-0.0725775

CHAPTER FIVE

SUMMARY, RECOMMENDATION AND CONCLUSION

5.1. SUMMARY

The project's main goal was to employ finite element analysis to track deformations in the University of Benin's physics department building. The study's objectives were to evaluate the building's structural integrity and identify any possible areas of weakness or deformations using finite element modeling and analysis. The study made clear how crucial it is to use numerical simulations and sophisticated computational methods to guarantee the longevity and safety of vital infrastructure. The project enabled proactive maintenance and repair methods and offered important insights into the building's structural performance by combining finite element analysis with periodic monitoring and inspection.

The project aims to reduce the risk of structural deformation, guarantee the building's long-term sustainability, and offer recommendations to guide future efforts to improve the efficacy, efficiency, and sustainability of the deformation monitoring program. It completes such objectives by putting in place a strong monitoring system and proactive maintenance strategies.

5.2. RECOMMENDATION

Based on the findings of this project, the following measures are recommended:

- **Institutionalize Periodic Monitoring:** Establish a regular monitoring regimen to continuously evaluate the structural integrity and deformation patterns of the Physics Department building. This proactive approach will facilitate early identification of potential issues, enabling timely interventions.
- **Invest in Advanced Monitoring Technologies:** Allocate resources to adopt cutting-edge monitoring techniques that can enhance the accuracy and efficacy of deformation tracking. Such technologies may include fiber optic sensors, laser scanning, or remote sensing solutions.
- **Community Involvement:** Promote community involvement and education about the value of structural health monitoring. Inspire active participation and the reporting of any structural abnormalities or deformations that are noticed.

5.3. CONCLUSIONS

In conclusion, the application of finite element analysis (FEA) for deformation monitoring of large surface structures, such as the Physics Department building, has proven to be both effective and reliable. This study demonstrated that finite element modeling enables precise and accurate detection of structural deformations, with the accuracy significantly improving as the density of monitoring points increases. The FEA approach employed not only facilitated the identification of deformation patterns but also provided a comprehensive framework for analyzing structural changes during a single observation epoch.

The study further revealed critical insights into the stress distribution within the structure, highlighting areas experiencing varying degrees of deformation. By analyzing the variance matrix of displacement vectors, it became evident that deformation was

not uniform across the structure, with certain points exhibiting more pronounced shifts than others. This detailed understanding of deformation variability allows for a more targeted approach to structural assessment and maintenance.

Moreover, the findings emphasize the importance of continuous monitoring using finite element analysis, as it ensures early detection of potential structural issues, thereby enabling timely intervention before significant damage occurs. The integration of this advanced computational method into routine monitoring practices enhances the resilience and longevity of critical infrastructure, safeguarding both users and assets.

Ultimately, the study underscores the potential of finite element analysis as an indispensable tool in modern deformation monitoring. Its ability to combine precision with comprehensive structural insights makes it invaluable for ensuring the long-term stability, safety, and functionality of buildings and other large surface structures.

REFERENCE

1. Area from Coordinates Version 1.6
2. Callister, W.D. & Rethwisch, D.G. (2018). Materials science and Engineering; An introduction. Wiley
3. Hibbeler, R.C. (2016), Mechanics of Materials. Pearson
4. Goodno, B.J., & Gere, J.M. (2012). Mechanics of materials. Cengage Learning.
5. MATLAB version 6.6
6. Beer, F.P., Johnson, E.R., Dewolf, J.T., & Mazurek, D.F. (2014), Mechanics of Materials. McGraw-Hill education
7. Callister, W. D., & Rethwisch, D.G. (2021). Materials Science and Engineering; An introduction (11th ed.). Wiley
8. Ashby, M.f., & Jones, D.R.H. (2012). Engineering materials 1; an introduction to properties, applications and design. Butterworth-Heinemann
9. Dowling, N.E. (2012). Mechanical Behaviour of materials ; Engineering methods of Deformation, fracture and fatigue. Pearson
10. Ehigiator – Irughe, R. (2019). Finite Element Application in Reservoir Deformation analysis (Pilot Phase 1). Nigerian Journal of Environmental Sciences and Technology (NIJEST. Vol 3, No. 2 October 2019, pp 245 – 255
11. Schrott, L., & Geib, C. (2018). Introduction to deformation monitoring, in Deformation monitoring. CRC press.

12. Mihail, D., Popescu, C., & Herbei, M. (2017). Deformation monitoring of tailing dams using robust techniques. Proceedings of the 11th international conference on mine surveying and mining geomatics. Sofia, Bulgaria
13. Huang, J., Dai W., Xu, Y., & Yang Y. (2021). A review of deformation monitoring methods and applications in underground mining. *Sensors*, 21(21), 4069.
14. Ehigiator – Irughe, R. Ashraf A. A. Beshr, J. O. Ehiorobo and O.M. Ehigiator (2011). Modification of Geodetic Methods for Determining the Monitoring Station Coordinates on the Surface of Cylindrical Oil Storage Tank. *Research Journal of Engineering and Applied Sciences (RJEAS)* 1 (1) pp. 58 - 63. A United State Academy publications USA.
15. Psimoulis, P., Hatzinakos, I., & Karavias. A. (2022). Deformation monitoring of structures and terrain; A review. *Applied sciences*, 12 (7), 3518
16. Ghilard, M., Barzaghi, R., & Cazzaniga, N. E. (2022). Deformation monitoring of the “Palazzo della Ragione” in Milan (Italy) by terrestrial laser scanning. *Applied geomatics* 14(1), 53-66
17. Mukpa, W., Ogaja, C., & Rizos, C. (2023). Geodetic deformation monitoring; An overview. *Survey Review*, 55(389), 69-84
18. Hu, X., Huang, J., Zhang, D., & Cheng, W. (2023). Geotechnical deformation monitoring of an open pit mine slope using multi sensor integration. *Geosciences*, 13 (3), 136.

19. Zeng, Q., Wang, X., Chen, j., & Lin, H. (2023). Structural deformation monitoring of a long - span bridge using terrestrial laser scanning and finite element analysis. *Sensors*, 23(6), 3145
20. Crosetto, M., Monserrat, O., Barra, A., & Crippa, B. (2023). Remote sensing deformation; Techniques and applications. *Remote sensing of Environment*, 284, 113355
21. Luo, L., Niu, X., Shu, Y., & Wu, W. (2023). Deformation monitoring of earth rock dams using a multi sensor data fusion; A case study. *Remote sensing*, 14(6), 1376
22. Scaloni, M., Lingua, A., Sammartano, G., & Segalini, A. (2023). Deformation monitoring of a heritage building by terrestrial laser scanning and point cloud comparison. *Remote sensing*, 15(6), 1396
23. Palazzo, D. R., Ardielli, J., & Gusmao, A. C. (2023). Deformation monitoring of a bridge using georeferenced terrestrial laser scanning data. *Boletim de Ciencias Geodesicas*, 29(1), e2023001
24. Berberan, A., Machado, M., Alves, P., & Fonseca, A. (2022). Deformation Monitoring of dams using terrestrial laser scanning. *Sensors*, 22(2), 614.
25. Zhu, J., Ding, X., Liu, G., Zhang, J., & Chen, Y. (2023). Multi-sensor integration for deformation monitoring of large span bridges; A review. *Remote sensing*, 15(3), 589
26. Kitsakis, D., Kougioumtzis, M., & Kapetanidis, V. (2023). Deformation monitoring of a highway bridge using terrestrial laser scanning. *Sensors*, 23(5), 2796.

27. Sładek, J., Sładeczek, Ł., & Jędrysiak, J. (2023). Finite element model updating based on static and dynamic measurements. *Archives of Civil and Mechanical Engineering*, 23(1), 1-19.
28. Xu, W., Zhuang, Z., & Yu, Q. (2023). Finite element model updating based on deformation measurements: A review. *Structural Control and Health Monitoring*, 30(2), e2913.
29. Nguyen, V. P., Rabbah, C., Bordas, S. P., & Nguyen, N. X. (2023). Isogeometric analysis of deformation and crack propagation in solids. *Computer Methods in Applied Mechanics and Engineering*, 406, 115480.
30. Salimi-Vajouh, H., & Downey, A. (2023). The extended finite element method for deformation modeling of structures with material discontinuities. *Engineering Structures*, 273, 115252.
31. Huang, J., Hu, X., Zhang, D., & Cheng, W. (2023). Discrete element modeling of rock slope deformation under dynamic loading. *International Journal of Rock Mechanics and Mining Sciences*, 158, 105425.
32. Yan, P., Cao, Z., Zhao, J., & Chen, W. (2023). Discrete element modeling of deformation behavior of rockfill materials under cyclic loading. *Acta Geotechnica*, 18(3), 1051-1068.
33. Beskos, D. E. (1997). Boundary element methods in dynamic analysis: Part II (1986-1996). *Applied Mechanics Reviews*, 50(3), 149-197.
34. Syngellakis, S. (2015). *Boundary element methods for soil-structure interaction*. Springer.

35. Chrzanowski, A., & Wilkins, R. (2006). Deformation monitoring and analysis at the Canadian Rockies. Proceedings of the 3rd IAG/12th FIG Symposium, Baden, Austria.

APPENDIX

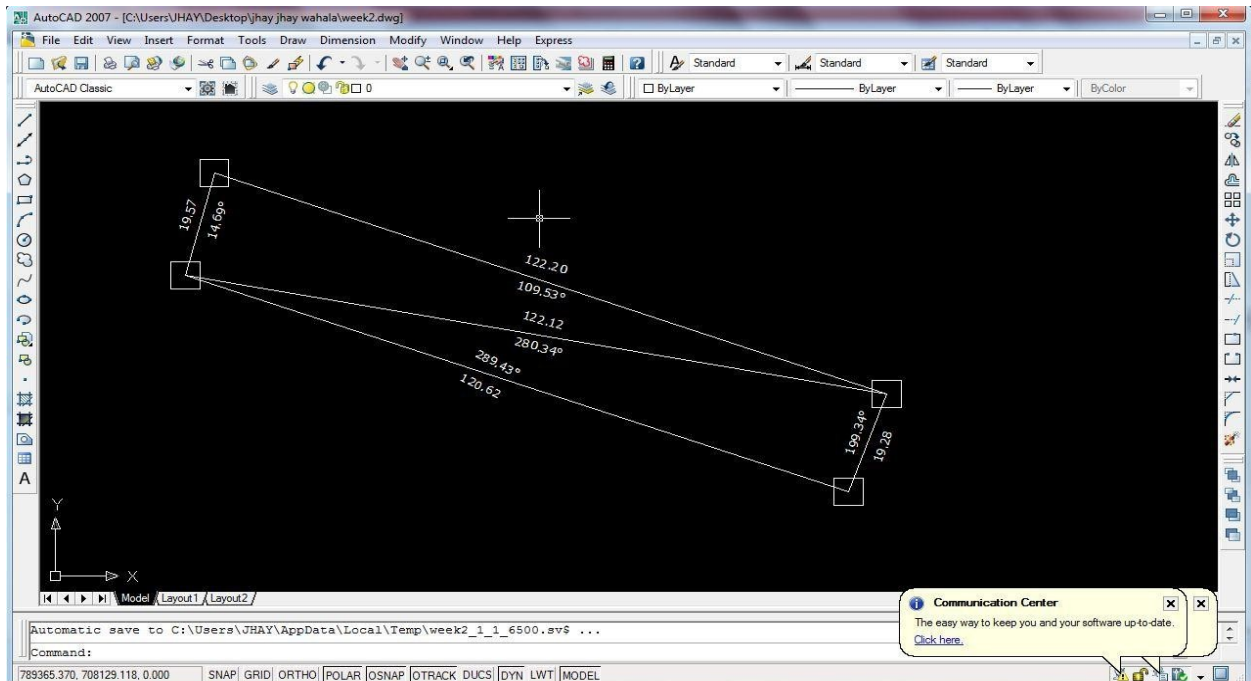
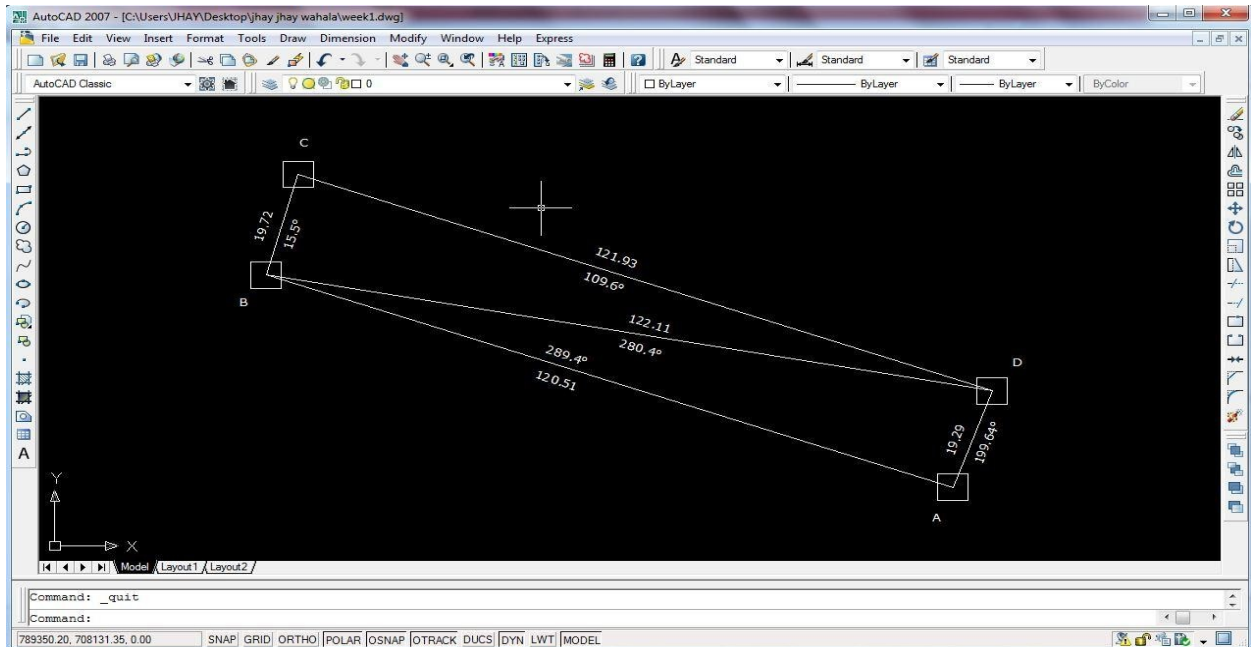

FIGURE A.1 Showing Autocad representation of the study area plotted with coordinates for week 1 and 2

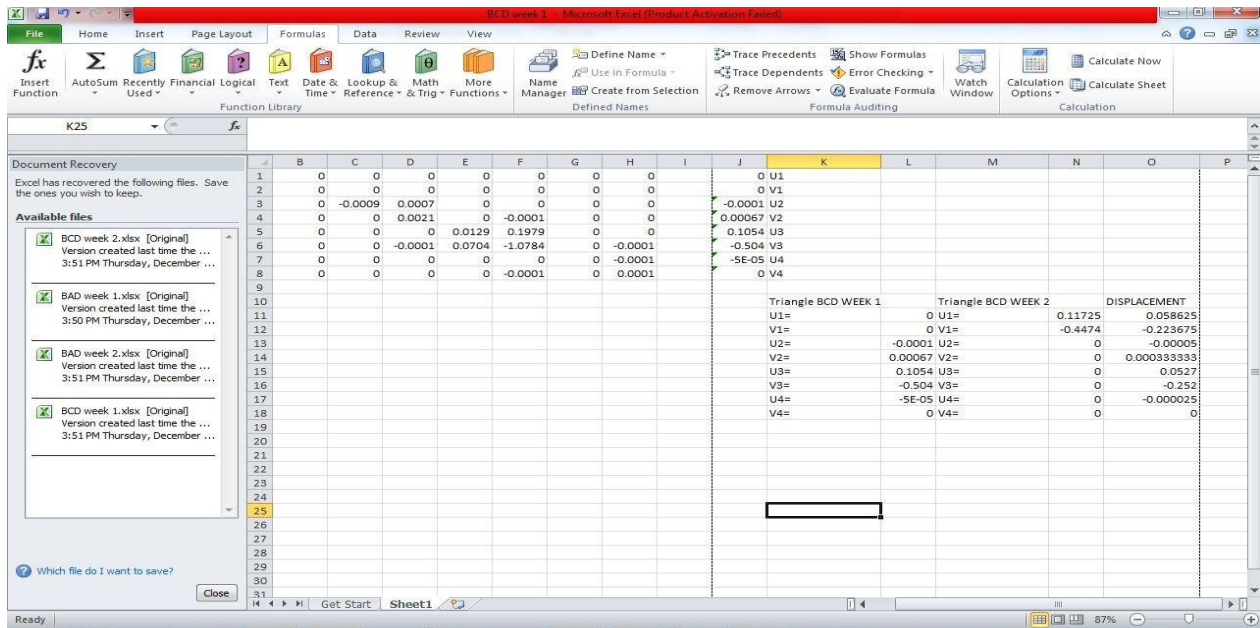

FIGURE A.3 Showing The Displacement Between week 1 and 2 for Triangle BCD

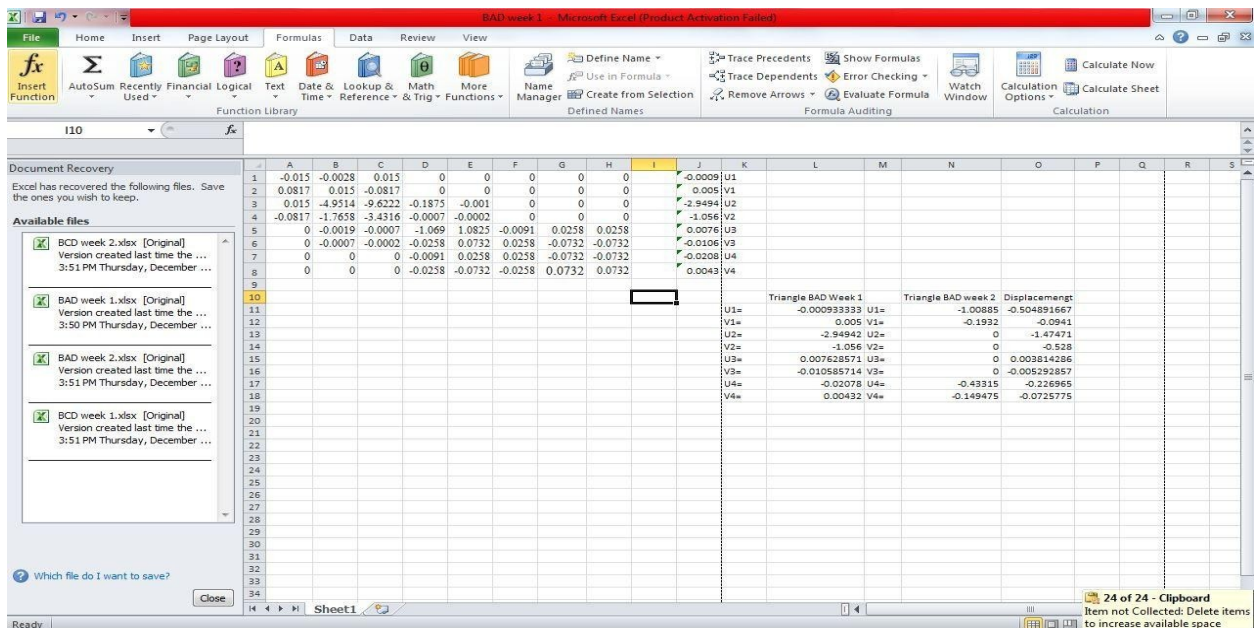

FIGURE A.4 Showing The Displacement Between Week 1 and 2 for Triangle BDA