



**CONSTRUCTION OF A
HANDHELD EXTENSIBLE BIOMETRIC ATTENDANCE REGISTRATION AND
DATA COLLATION DEVICE**

BY

ADEBIYI EMMANUEL OLUWAGBEMIGA

ENG1503549

SUPERVISED BY

ENGR. DR. O. I. OMOIFO

DEPARTMENT OF COMPUTER ENGINEERING

FACULTY OF ENGINEERING

UNIVERSITY OF BENIN

**A THESIS SUBMITTED IN PARTIAL FULFILMENT OF THE REQUIREMENTS FOR
THE AWARD OF THE DEGREE OF BACHELOR OF ENGINEERING (B.ENG) IN
COMPUTER ENGINEERING, UNIVERSITY OF BENIN, AND EDO STATE, NIGERIA.**

JULY 2021

CERTIFICATION

This is to certify that **ADEBIYI EMMANUEL OLUWAGBEMIGA**, an undergraduate student in the Department of Computer Engineering, Faculty of Engineering, University of Benin, Edo state, with Matriculation number **ENG1503549** satisfactorily completed this work on his own as a partial fulfilment of the requirement for the award of Bachelor Degree in Engineering (B.Eng.) in Computer Engineering.

Dr. U.I Iruansi
(HOD)
Date

-----Engr.
Engr. O.I.Omoifo
(Supervisor)
Date

ACKNOWLEDGEMENT

With an exceedingly grateful heart, I express gratitude to the Almighty God for granting me the fortitude to start and finish this project. Great thanks also go to my parents (and family) whose constant support, prayer and care has been the fuel that has driven me through my undergraduate years in this institution. Finally, this acknowledgment would be incomplete without the mention of my Project Supervisor (Engr. Dr. Omoifo) and my project colleagues whose help, this project might have never seen the light of the day.

DEDICATION

This project is dedicated to the Almighty God, for His wondrous love and ever-present help towards me. It is also dedicated to my family i.e., my parents and siblings for their support throughout this journey.

ABSTRACT

In many institutions, business firms and organizations, the collection of attendance data is taken very seriously as the management at these organizations tend to dislike absenteeism, late coming and these organizations seem to sanction the individuals involved. These organizations also hope to encourage punctuality by rewarding people who are perpetually on time.

Traditionally, the method of attendance taking used to be done manually using a physical register booklet. This method is prone to manipulation and impersonation. The attendance register could get damaged, stolen or lost. Therefore, several electronic techniques were developed to counter some notable flaws typical with the traditional method. These electronic techniques are not without flaws and drawbacks as well.

This project implements a solution that makes use of an electronic technique (Biometric Fingerprint Recognition) for human identification as well as some other novel techniques to battle gaffes present in currently used technologies.

Table of Contents

CHAPTER ONE (INTRODUCTION)	3
1.1 BACKGROUND OF STUDY.....	3
1.2 PROBLEM STATEMENT.....	6
1.3 AIMS AND OBJECTIVES.....	6
1.4 METHODOLOGY.....	7
1.5 SCOPE OF STUDY.....	7
CHAPTER TWO (LITERATURE REVIEW)	8
2.0 INTRODUCTION	8
2.1 CONCEPTUAL REVIEW	9
2.2 RELATED WORKS.....	8
CHAPTER THREE (METHODOLOGY)	11
3.1 HARDWARE IMPLEMENTATION.....	11
3.2 SOFTWARE IMPLEMENTATION.....	11
CHAPTER FOUR (RESULTS AND DISCUSSION)	12
4.0 VERIFICATION OF FUNCTIONALITY.....	12
4.1 SUMMARY OF RESULTS	12
4.2 BILL OF ENGINEERING MEASUREMENT AND EVALUATION (BEME).....	12
REFERNCES	1
APPENDIX	14

LIST OF FIGURES

- Figure 2.1 - Illustration of Attendance Marking
- Figure 3.1 - Block Diagram of Hardware Implementation
- Figure 3.2 - Pinout of R307 Fingerprint sensor
- Figure 3.3 - UML Use Case Diagram of Attendance System
- Figure 3.4 - UML Sequence Diagram for generating Attendance Report
- Figure 4.1 - Client Application: Sign Up
- Figure 4.2 - Client Application: Sign In
- Figure 4.3 - Client Application: Create Attendance Project
- Figure 4.4 - Client Application: Project Dashboard
- Figure 4.5 - Client Application: Attendance Project Interface
- Figure 4.6 - Client Application: Enrol Person
- Figure 4.7 - Client Application: Add New Event I
- Figure 4.8 - Client Application: Add New Event II
- Figure 4.9 - Client Application: Attendance People list
- Figure 4.10 - Client Application: Person's Details I
- Figure 4.11 - Client Application: Person's Details II
- Figure 4.12 - Client Application: Create Data Collation Project
- Figure 4.13 - Client Application: Data Collation Project Interface I
- Figure 4.14 - Client Application: Add Questions I
- Figure 4.15 - Client Application: Add Questions II
- Figure 4.16 - Client Application: Data Collation Project Interface II

CHAPTER ONE

INTRODUCTION

Biometrics refers to the automatic identification of a person based on his or her physiological or behavioural characteristics. It includes fingerprint, iris, facial and retinal. Biometrics technologies are becoming the foundation of an extensive array of highly secure identification and personal verification solutions. Today, biometric is being spotlighted as the authentication method because of the need for reliable security (Cappelli et al., 2007).

Biometric Attendance systems are commonly used systems to mark people's presence in offices and schools, giving it a very large demand due to its wide application in school, college, business organization, offices or any firm where marking of attendance is required accurately with time. The Fingerprint verification is one of the oldest known biometric techniques known but still the most widely used because of its simplicity and good records of accuracy. It is a well-known fact that every human being is born with a different pattern on their fingers and these features are used to identify and differentiate between two different persons.

The benefit of this application in an educational institute or organization cannot be overemphasized. The fingerprint recognition and verification technique has been adopted to replace the conventional method as it saves time and eliminates many setbacks identified with the attendance register booklet like impersonation and inaccurate timing. The fingerprint scanning device is usually placed at a central place in a physical premise, and all employees or students (as the case may be), would be required to swipe their finger across the sensor to indicate their presence at that premises. The attendance records are then stored in a local database where they can be retrieved for usage or further processing.

This project solves popular problems which the regular biometric systems have failed to solve by using a standalone "Internet of Things (IoT)" device which has an online backend system and an external web client.

The system will be implemented in such a way that it increases flexibility in data management, allows ease of exporting and synchronisation and as well provide internal fail-safe systems to handle sudden failure like power loss or loss of internet connectivity.

1.1 - BACKGROUND OF STUDY

Every human establishment comprise of a hierarchy of human administrations. These administrative affairs usually require a system of collecting, collating and coordinating individual human involvements for different purposes including effective disbursement of remuneration.

The Industrial Revolution, which brought major changes to several economies, saw an influx of manual labour in newly industrialized factories. Factory owners loved child labour because it was cheap and unregulated. However, it wasn't long before the government stepped in to help improve factory conditions and regulate how many hours people were made to work, especially children. Factory owners needed a way to keep track of worker hours. This gave rise to the first time and attendance systems. (Source: <https://www.redcort.com/its-about-time/history-of-time-and-attendance-systems>.)

Albeit, these traditional systems of marking attendances were not without their challenges. They were mostly based on paper which is relatively easy to tamper, forge or wrongly modify. They also required the presence of a trusted person who was in charge of managing the system. If the attendance keeper is compromised, this means the attendance data will also be compromised.

Another notable problem with the traditional system was the durability of the records. As stated earlier, they were mostly based on paper which means they had to be stored in physical folders of shelves where they were at danger of destruction by pests or other natural conditions. Lastly, retrieval of data was relatively difficult. A simple attempt to retrieve records from a few months back would usually lead to long minutes or hours of looking and searching.

With the advent of the digital age where the computer and other electronics prevailed over most existing traditional systems, many solutions have been made, and are still being made in an attempt to solve the problem of attendance tracking.

1.2 - PROBLEM STATEMENT

It is obvious to most that these traditional systems (and even the existing modern solutions) have glaring drawbacks which make them infeasible or hard to use in certain scenarios. This project aims to proffer lasting solutions to some of these problems which are presented as questions below:

- How can organisations access data on their biometric attendance systems without physical access to the devices?
- How can organizations automatically generate spreadsheet with basic statistical information from these devices instantly without needing a Database Administrator to manually extract and prepare them.
- What will be the fate of data collected by the biometric attendance device in case of sudden failure?
- How can biometric attendance systems improve the flexibility of these systems with respect to deadlines in the event of changes in schedule or other unforeseen circumstances?
- How can these biometric attendance systems be extended to allow the recording of data which are usually needed at the point of registering attendance such as ‘reason for attendance’?
- How can these systems be made portable so that they can easily be moved around and re used at different physical locations?

1.2 - AIM AND OBJECTIVES

The aim of designing and implementing this Biometric Attendance System is to provide a handheld device to register a user’s data, marks their attendance while providing real time synchronisation, and easy ability to view, manipulate and export data on the fly.

1.2.1 - Objectives

- To design and implement a generic Attendance System based on Fingerprint Biometrics Technology.
- To be able to back up the regular attendance in an online database and query it in real time.
- To implement the system such that it provides ease and flexibility for reviewing and changing attendance deadline benchmarks.
- To allow easy generation and exporting of attendance data in a standard spreadsheet for further processing.
- To provide a fail-safe architecture to prevent data loss in the case of sudden failure
- To provide a system that allows additional input of any other data required from the users
- To compare efficiency between this system and the traditional system.
- To compare efficiency between this system and the currently existing biometric systems
- With this system, the administrator can record the attendance of their students in class easily, as they also do not have to count the percentage of every student at the end of the semester.

1.3 - METHODOLOGY

This project innovates in the space of attendance tracking systems by utilising the portability and power of modern board computers, specifically the Raspberry Pi 3B as well as the versatility of the web to build a smart, efficient and portable solution. It combines a local server running on a low-power board computer with a finger print sensor and communicates over the internet with a cloud-based server that allows backup, and real time data retrieval.

1.4 - SCOPE OF STUDY

This project is primarily focused on improving the portability, security and efficiency of attendance monitoring systems for use in institutions, organisations and businesses.

CHAPTER TWO

LITERATURE REVIEW

2.0 - INTRODUCTION

Currently, the attendance tracking system based on biometric recognition for education sectors is still underutilized, thus providing a good opportunity to carry out interesting research in this area (Seng Chun Hoo et al., 2019). The top three sectors which utilize biometric in their applications are financial services, technology and government, according to a May 2018 report by Rachel L. German and K. Suzanne Barber from CID (Center of Identity), University of Texas at Austin. This is closely followed by the workplace, recreation, and healthcare and with the least utilization in education domain. The reason(s) for this underutilization, what this project aims to address, is explored in this chapter while following the development of the biometric technology over the years.

2.1 CONCEPTUAL REVIEW

Every human establishment comprise of a hierarchy of human administrations. These administrative affairs usually require a system of collecting, collating and coordinating individual human involvements for different purposes including effective disbursement of remuneration.

The Industrial Revolution, which brought major changes to several economies, saw an influx of manual labor in newly industrialized factories. Factory owners loved child labor because it was cheap and unregulated. However, it wasn't long before the government stepped in to help improve factory conditions and regulate how many hours people were made to work, especially children. Factory owners needed a way to keep track of worker hours. This gave rise to the first time and attendance systems. (Source: <https://www.redcort.com/its-about-time/history-of-time-and-attendance-systems>.)

2.1.1 Concept of Attendance System

One of the first time and attendance systems, the time card, was developed in the late 1880's and

was basically a mechanical time clock that would stamp day and time information on a thick paper card – hence the name. It was effective but expensive to repair and replace and very prone to ‘buddy punching’.



Figure 2.1

Prior to the invention of mechanical time and attendance systems, companies had to monitor attendance and hours worked by a variety of manual means. This includes, but is not limited to, visual checks, personal recording using timesheet, et c. Some of which may still be employed in some enterprises today.

These were relatively cost-effective but not very efficient (accurate). For example, the visual checks were open to dispute as it had high probability of supervisory oversight, and was just a matter of one person’s word against another and the recording with timesheet or time clock gave rise to falsified start and end of day times.

Soon, however, cheap computer technology would be innovated in the 1990’s and many businesses would migrate away from mechanical to computerized time and attendance systems. This largely reduced many inefficiencies experienced with former systems as the process of collecting data electronically could be largely automatic. The evolution of chip technology since the late 90’s has led to even more innovation in the time and attendance systems development. Some examples of automated, computerized attendance systems are:

- RFID card-based attendance system

- Barcode attendance tracking system
- Smart card access control attendance system
- Magnetic strip-based attendance system
- Biometric attendance system

Of all the above types, the biometric stands out as most prominent, has increasingly become more common and continues to see most advancements as, in recent times, biometrics based on brain and heart signals have emerged.

2.1.2 Biometrics

According to Oxford Learners Dictionary, biometrics is simply using measurements of human features to identify people. The term is derived from the Greek words Bio meaning Life and Metric meaning To Measure. It is the measurement and statistical analysis of people's unique physical and behavioral characteristics.

The biometric attendance systems employ novel sensors, robust and efficient algorithms for feature extraction and label matching, and is increasingly more easily adopted than any other automated attendance type. Components of biometrics usually include:

A scanner to record the biometric entity being authenticated.

Software to convert the scanned biometric data into a standardized digital format and to compare match points (features) of the observed data with stored data.

A database to securely create, retrieve and update biometric data for comparison.

2.1.2.1 Types of Biometrics

Essentially, there are three well known types of biometrics.

- Chemical biometric – DNA matching
- Behavioral biometric – Gait, Typing dynamics, Engagement patterns, Signature recognition

- Physiological biometric – Hand geometry, Eye (Iris/retina) recognition, Palm vein recognition, Voice scanning, Fingerprint recognition

Among all aforementioned biometric types, Fingerprint features are considered to be the best and fastest method for biometric identification and hence the chosen type to be employed in the project.

2.1.2.2 Advantages of Biometrics

Because biometrics can provide a reasonable level of accuracy in authenticating a person with less friction for the user, its potential to dramatically improve enterprise security is currently unmatched. According to a Ping Identity survey, a whopping 92 percent of enterprises rank biometric authentication as "effective" or "very effective" to secure identity data stored on premises, and 86 percent say it is effective for protecting data stored in a public cloud. Below are some reasons:

- Authentication credentials like fingerprint scans or voice recordings can hardly be doctored (by a hacker or robot) to mimic the original.
- Since biometrics features are peculiar for every human, ‘buddy’-related discrepancies are largely avoided.
- Biometric data are digital and take up little storage space, unlike several other automated attendance types that are large in size and may take up even physical office spaces e.g., Magnetic strip-based attendance system.
- Length of time it takes for a biometric identification process to commence and end is relatively fast.

However, some cons of biometric attendance systems are as follows:

- Authentication credentials can leak from devices, from company servers or from software used to analyse them.
- Potential for false positives and false negatives.
- It is costly to set up and maintain a biometric system.

2.1.3 Data Collation Techniques

Data gathering is a common phenomenon all through history. Different techniques have been used for the purpose of data gathering over the years such as direct observation, surveys/questionnaires, interviews and focus groups (Data Collection Techniques, Fulcrum).

In the more recent times, surveys have dominated these efforts and it is majorly carried out through online survey platforms like Google Forms. While there is much improvement in this space, most of these newer techniques do not have the reach and accessibility that the traditional (paper-based) systems had mostly due to unavailability of (or inadequate) network infrastructure.

2.1.4 Gap Analysis For Biometric Attendance Systems

The major reasons for the underutilization of fingerprint-based biometric attendance systems are:

- Cost of setting up and maintaining enterprise-grade biometric system.
- Security and privacy concerns with the use of students' biometric data.
- Unencouraging experience with existing biometric attendance systems.

Having reviewed these gaps in the course of this chapter, the project thus aims to bridge this by:

- Implementing a cheap, portable, scalable and also enterprise-grade fingerprint-based biometric attendance system.
- Ensuring students' data is used for stated purpose and stated purpose alone, by primarily including a Terms and Conditions document for using the system.
- Introducing personalized responses, to encourage utilization by students, into the system and allowing students monitor their own attendance via the internet.

2.1.5 Gap Analysis for Data Collation Methods

The major improvement needed in this regard is the implementation of a solution that can be independent of external networks while at the same time having the capacity to utilise networks, when available to improve its ease of reach of data.

2.2 - RELATED WORKS

2.2.1 - Attendance Monitoring System of Students Based on Biometric and GPS Tracking System. J.Chandramohan, R.Nagarajan, M.Ashokkumar, T.Dineshkumar, G.Kannan, R.Prakash. International Journal of Advanced Engineering, Management and Science (IJAEMS) [Vol-3, Issue-3, Mar- 2017] <https://dx.doi.org/10.24001/ijaems.3.3.16>.

IMPORTANCE OF WORK

The Fingerprint attendance management system is one of the safest biometric authentication methods widely used, as it cannot be forged easily.

The Fingerprint authentication has a very high accuracy. It has the most economical biometric PC user authentication technique.

It is very easy to use. With the integration and use of biometric technology getting simpler, many institutions are using down the biometric road to verify the time and attendance of their students and staff.

The use of cloud computing to store the attendance records makes all the data easy to access and retrieve as end when required by the teachers.

The use of fingerprint scanner ensures the reliability of the attendance record. The system, due to its lack of complexity, proves to be easy to use and user friendly.

LIMITATION OF WORK

The system needs to be constantly connected to an external computer.

The data cannot be extracted without physical access.

The implementation of the system is heavily reliant on GSM, a service which is oftentimes unreliable.

2.2.2 - IoT Based Biometric Attendance System. Piyush Devikar, Ajit Krishnamoorthy, Aditya Bhanage, Mohit Singh Chauhan. International Journal of Advanced Research in Computer and Communication Engineering (ICRITCSA). M S Ramaiah Institute of Technology, Bangalore Vol. 5, Special Issue 2, October 2016.

IMPORTANCE OF WORK

The stored data is backed up by uploading to an online Google Spreadsheet.

LIMITATION OF WORK

The system is internet dependent. It must be constantly connected to the internet.

2.2.3 An android based course attendance system using face recognition. Dwi Sunaryonoa, Joko Siswantorob, Radityo Anggoro (2018). Journal of King Saud University - Computer and Information Sciences.

IMPORTANCE OF WORK

The system uses facial recognition which is another popular means of biometric identification of humans. It also uses Android devices which are ubiquitous in many societies reducing the need for the cost of building an extra device.

LIMITATION OF WORK

The system is phone dependent (Android). So many factors can make phones unavailable or disallowed for use at different scenarios. Also, as the authors pointed out, the attendance system which requires every student to use a personal phone for the recording of their attendance can easily be cheated as there is no way to ensure students are in class (Dwi Sunaryonoa et al).

2.2.4 - Development of Fingerprint Biometric Attendance System for Non-Academic Staff in a Tertiary Institution. Adewole K. S., Abdulsalam S. O., Babatunde R. S., Shittu T. M. and Oloyede M. O (2014). Department of Computer Science, University of Ilorin.

IMPORTANCE OF WORK

This system generates monthly attendance reports. It also allows some flexibility for taking 'Time-in' and 'Time-out' attendances.

LIMITATION OF WORK

The system is based on a software program which can only be installed on a computer. This reduces mobility and increases dependence on external power supply

2.2.5 - Development of Academic Attendance Monitoring System Using Fingerprint Identification. Tabassam Nawaz, Saim Pervaiz, Arash Korrani, Azhar-Ud-Din. (IJCSNS) International Journal of Computer Science and Network Security, VOL.9 No.5, May 2009.

IMPORTANCE OF WORK

The data generated is stored into an SQL Server database which makes it easy for the system to generate reports.

LIMITATION OF WORK

The system is computer based and hence has poor mobility. Also, the system does not identify any way to store miscellaneous attendance related data.

CHAPTER THREE

METHODOLOGY

In this chapter, we would discuss the different steps and composing components that was involved in the implementation of the biometric system.

This can be structurally divided into two parts – the hardware, and software.

3.1 - HARDWARE IMPLEMENTATION

3.1.1 - Hardware Components used

Raspberry Pi 3B, Fingerprint sensor (R307), 7-inch LCD screen, Mini Keyboard/Touchpad for Raspberry Pi, 16GB SD Card.

3.1.2 - Implementation Procedure

1. The display monitor which is connected to the Raspberry Pi via an HDMI connector through a separate display driver circuit.
2. The mini-USB keyboard and mouse which is required to inputs data and control the Raspberry Pi is connected through a wireless 2.4GHz connection. The specific wireless connection for the mini-USB keyboard and mouse is provided by the USB dongle connected to one of the USB ports of the Raspberry Pi
3. The 16GB SD Card is formatted and the Raspberry Pi OS is burned onto it using the Raspberry Pi Imager Software program, which is the official software from the Raspberry Pi Foundation.
4. SSH and VNC are enabled on the Raspberry Pi by creating empty text files with the name 'ssh' and 'vnc' respectively.
5. Wi-Fi should also be configured by creating the 'wpa_supplicant.conf' file and specifying the network SSID and passkey to an available Wi-Fi network in the configuration.
6. The SD card is then inserted into the Raspberry Pi and the it is powered on through a 5V micro-USB connection.

7. Once the Raspberry Pi is powered on, it automatically connects to the pre-configured network and now remote access is possible via SSH for deployment and execution of code and scripts.

The procedures above are embodied in the block diagram below:

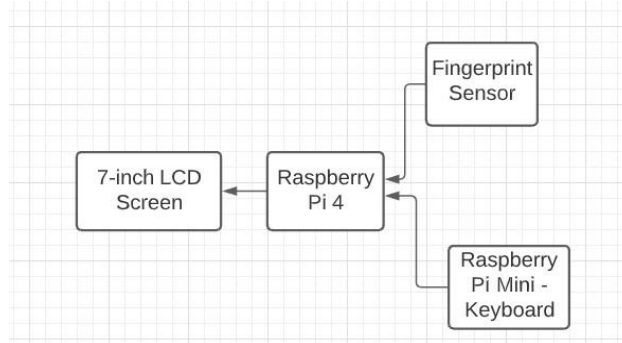

Fig 3.1

3.1.3 - Other Requirements and Setup Information

The Fingerprint sensor is connected to the USB port of the Raspberry Pi through a USB Universal Asynchronous Receiver Transmitter (UART) converter which helps allow the fingerprint sensor communicate through the serial ports.

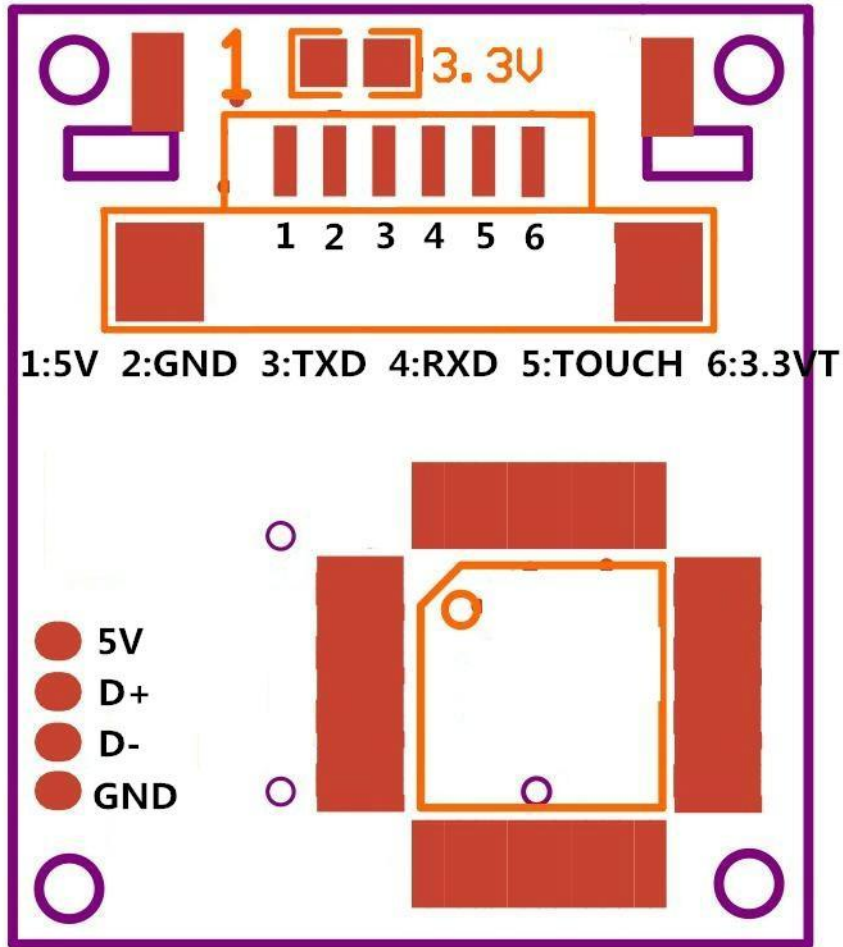

Figure 3.2

The schematic diagram of the R307 is shown above. The 5V and GND pins (Pin 1 and 2) are connected to the 5V and GND pins of the USB UART converter. TX and RX are also connected to the equivalent TX and RX pins of the USB UART. All other pins are unused in this implementation.

Some other requirements to note are:

- The Raspberry Pi was set up with username 'pi' and password 'geesRecorder'
- The PyFingerprint Library was installed with the following snippet on the command line: 'pip3 install pyfingerprint'
- The .NET SDK was also installed on the Raspberry Pi

3.2 - SOFTWARE IMPLEMENTATION

3.2.1 - Development Tools used

- Visual Studio 2019
- Visual Studio Code
- .NET 5.0 SDK
- C# extension for Visual Studio Code
- Mono Debug extension for Visual Studio Code

3.2.2 - Languages used

The languages used for development include the following C#, Razor (markup syntax), JS, HTML, CSS.

3.2.3 - Frameworks used:

- ASP.NET Core Web Api (for the API and Website which will run on online servers)
- ASP.NET Core Blazor WebAssembly (for the client application which will run locally on the Raspberry Pi 3B, but can also be extended to other devices).

3.2.4 - Software Implementation Details

This software part of the attendance system is comprised of two parts namely:

I) The Client Application which runs on the device

II) The Web Application which links the device to the database and as well provides an interface for real time monitoring, manipulation and exportation of data.

3.2.4.1 - The Client Application

The Client Application is built with Blazor WASM. Blazor WASM is a Single Page Application front-end web framework based on WebAssembly which is an open web standard.

The Blazor App is hosted within an ASP.NET Web Server which allows for direct interop with the bare metal machine which is normally outside of the scope of the JavaScript sandbox. This allows us to directly interop the fingerprint sensor with the application. That being said, the Client Application's purpose is to provide an interface to the two major functions of the device – Attendance Tracking and Data Collation.

The Client Application works hand in hand with the local server as well as the cloud server to achieve functions such as Authentication and Synchronisation. However, only the local server and its database are employed for other functions such as enrolment of attendants and their fingerprints, marking of attendance and other related functions.

The operation of the fingerprint sensor is controlled by scripts written in Python programming language. The scripts are executed by the local server when needed and the communication between the Client Application and the sensor is handled by a web technology known as SignalR. Fingerprints templated after enrolment are stored in the flash memory of the R307 fingerprint sensor which has the ability to store up to 1000 unique fingerprints. Also, the ID for each fingerprint is stored on the SQLite database against the records of the enrolled registrant. This comes handy when attendance marking is being done as it helps to map the correct fingerprint to the correct person. It is important to note that attendance marking is only allowed to occur during the pre-set time bounds of an event.

On the Data Collation side of things, all operations occur strictly between the local server and the Blazor application. The app allows a user to create a set of customisable questions which can then be published as a survey for. Once published, the survey can hence take responses which can be extracted into other formats for further analysis.

As a security measure, navigating out of a non-sensitive page is allowed only for the administrator of the device as a pin is required to proceed.

3.2.4.1 - The Web Application

The Web application can be further subdivided into two parts – the Web API and the Website.

The Web API is the interface that links the Cloud server with the Client Application running on the Raspberry Pi. It is responsible for the generation, sending, and verification of authentication tokens as well as handling authentication related operations like Signing Up, Signing In etc. Apart from this, the API also serves as the window through which synchronisation of data is performed. Data from the Attendance register as well as that from the data collator is synchronised with the cloud at an interval which is currently set at 5 minutes. Note that the synchronisation works only as long as the Raspberry Pi is connected to the internet. While disconnected from the internet, the local server keeps storing the data on the local database and synchronisation is paused until internet connection is regained.

The website on the other hand allows the user to query, retrieve and access the data on the device in real time. The website uses the synchronised data to display analytics of the data to the user. It also allows the user to export the data to other formats for further processing.

The API is powered by ASP.NET Web API and the website uses ASP.NET razor pages.

The use case scenarios for the attendance system is shown by the UML ‘Use Case’ diagram below. The diagram illustrates an educational scenario where a lecturer and students use the device.

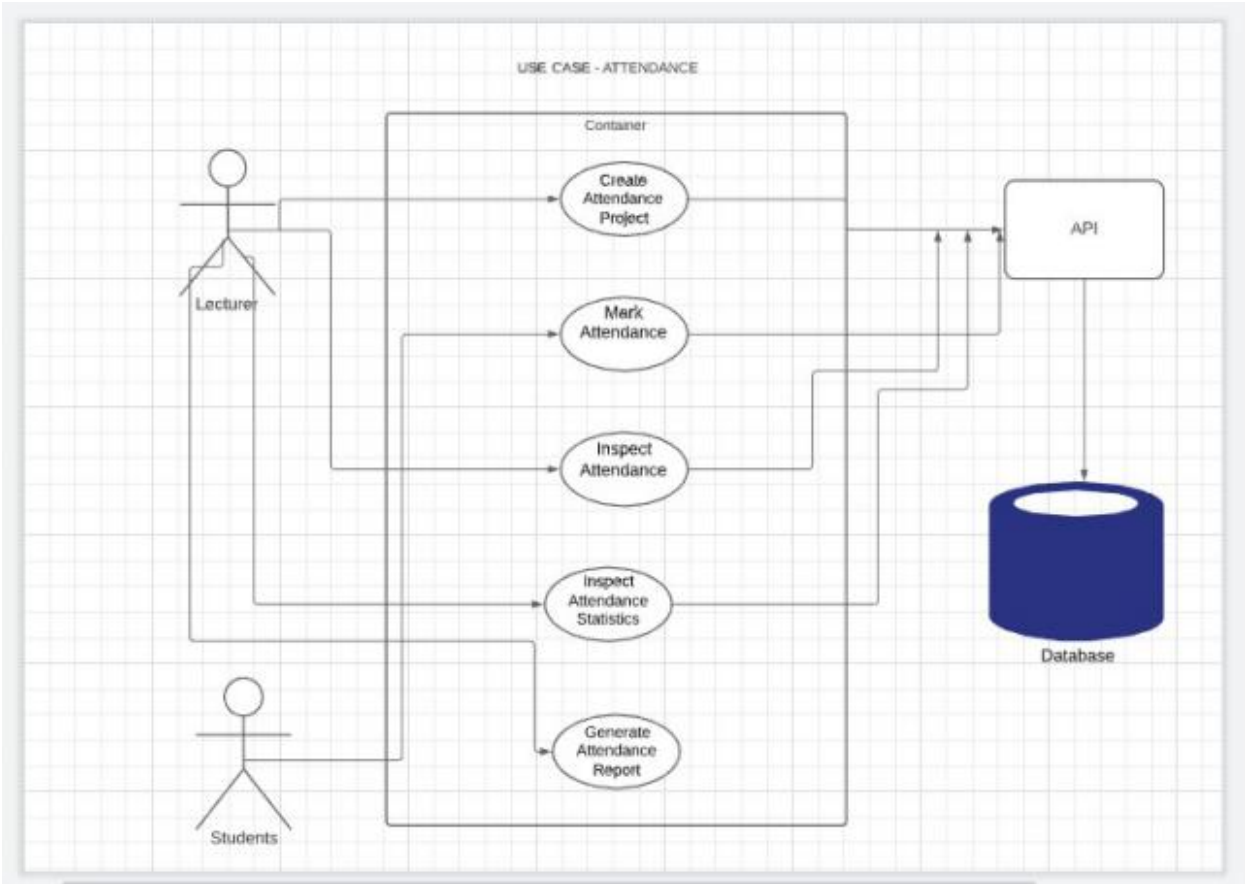

Figure 3.3

The sequence of operations for generating an attendance report is illustrated by the UML Sequence diagram below:

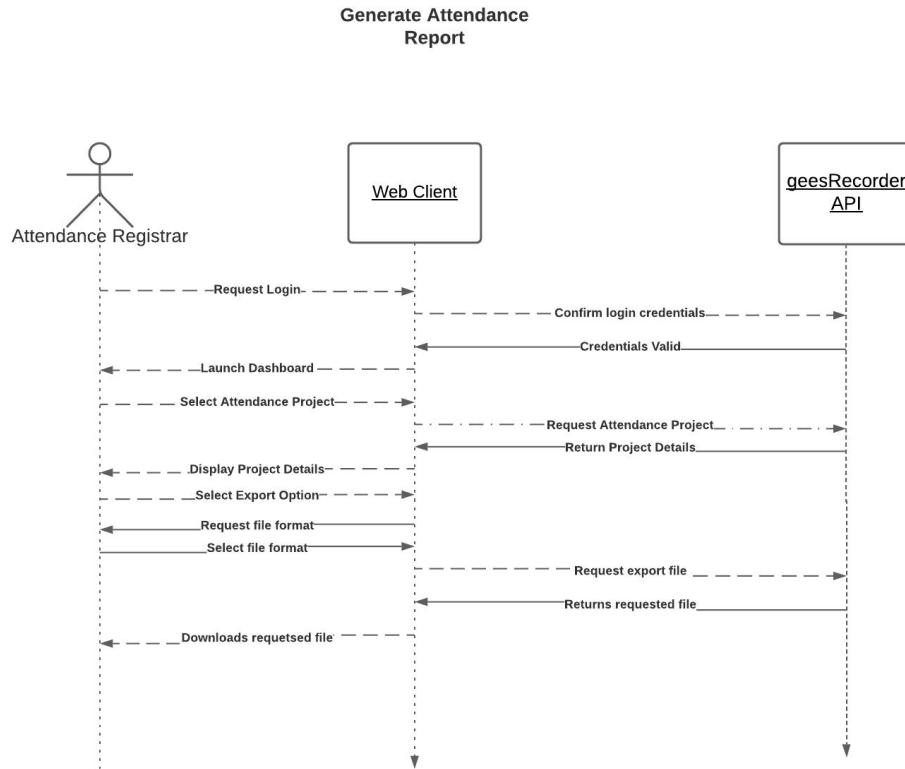

Fig 3.4

For further information, visit <https://github.com/AmSmart/geesRecorder> which is the Git repository where the complete source code for the project resides.

CHAPTER FOUR

RESULTS AND DISCUSSION

4.1 - VERIFICATION OF FUNCTIONALITY

4.1.1 - Client Application

Upon fresh start-up of the device, the user meets a welcome screen which allows them to create a new account or sign into an existing account.

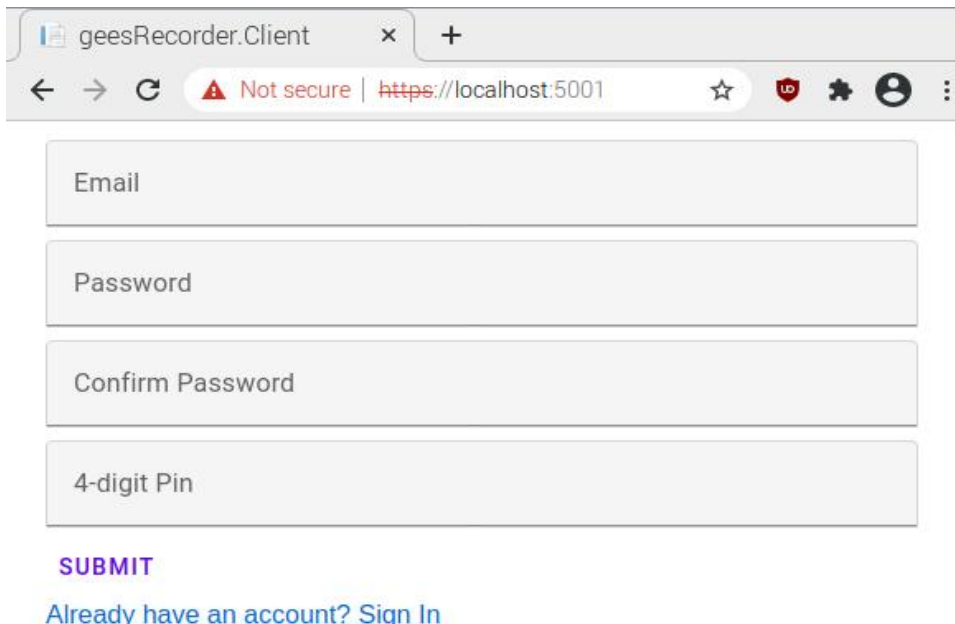

The screenshot shows a web browser window with the title "geesRecorder.Client" and the URL "https://localhost:5001". The browser's address bar indicates "Not secure". The page content consists of four input fields stacked vertically: "Email", "Password", "Confirm Password", and "4-digit Pin". Below these fields is a purple "SUBMIT" button and a blue link that reads "Already have an account? Sign In".

Figure 4.1

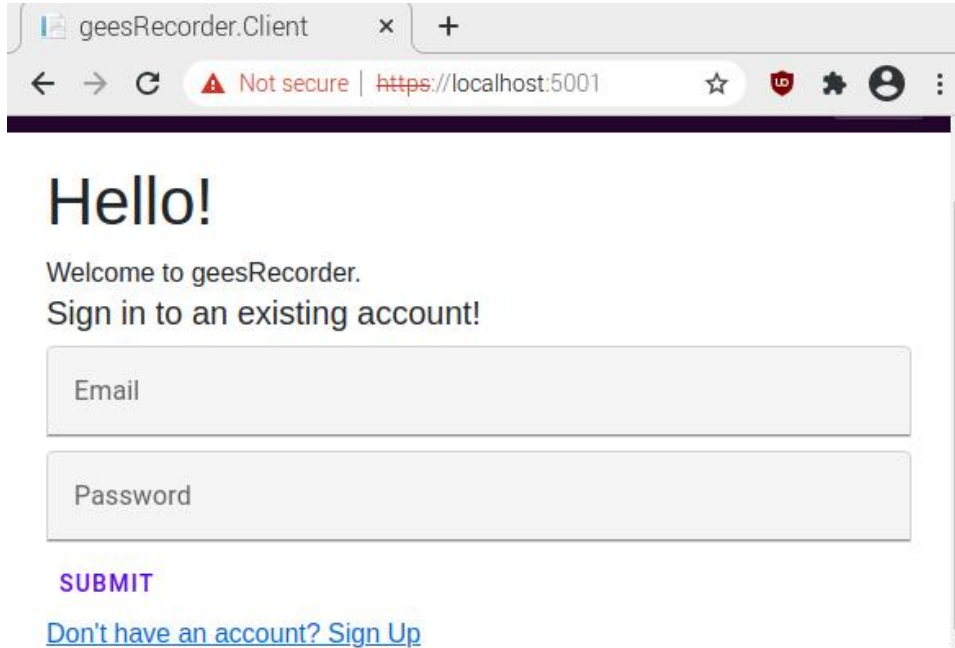

The screenshot shows a web browser window with the title "geesRecorder.Client" and the URL "https://localhost:5001". The browser's address bar indicates "Not secure". The page content features a large "Hello!" heading, followed by the text "Welcome to geesRecorder. Sign in to an existing account!". Below this text are two input fields: "Email" and "Password". At the bottom of the form is a purple "SUBMIT" button and a blue link that reads "Don't have an account? Sign Up".

Figure 4.2

After successful sign up or sign in, the user is redirected to the project dashboard where they have the option of creating new projects or opening existing ones. The figure below illustrates the creation of an attendance project named for “CPE 526” class.

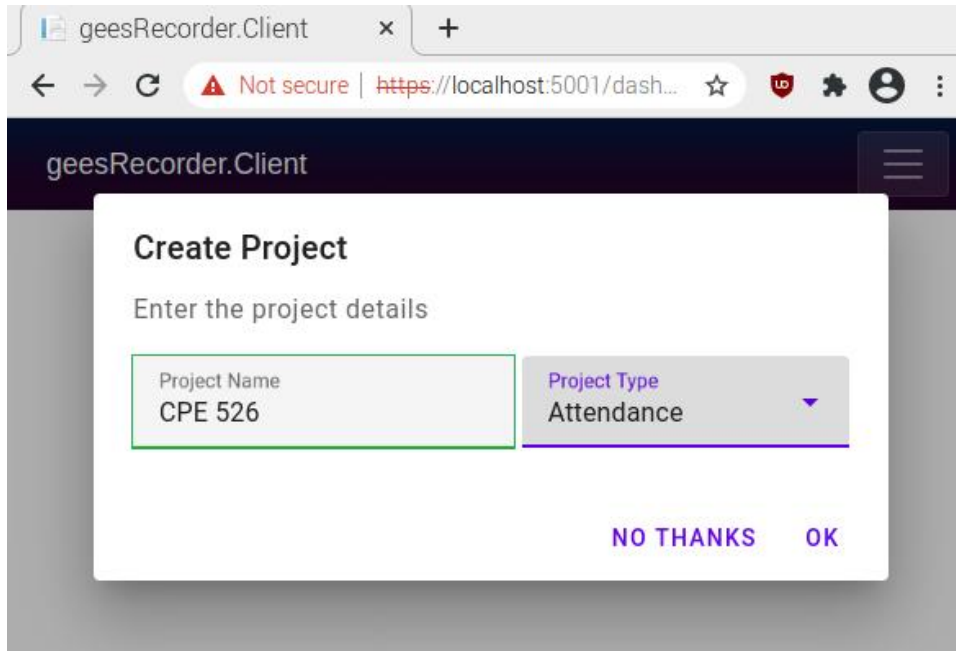

Figure 4.3

It is important to note that the dashboard allows users to open or delete their existing projects as shown below:

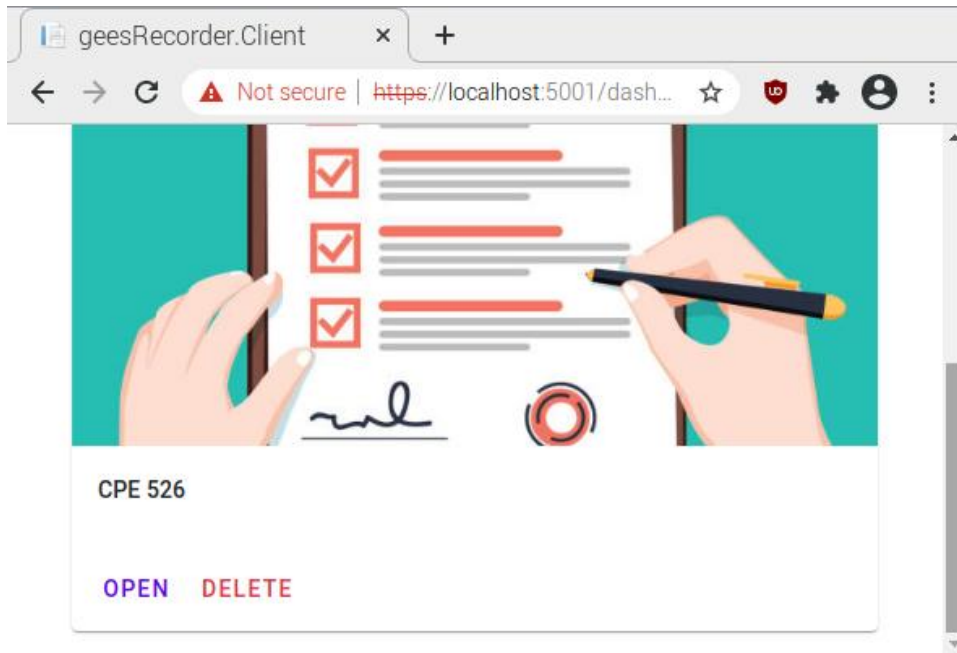

Figure 4.4

Once an attendance project is created, the user can open the project and perform actions. The “CPE 526” attendance project illustrated above is opened and shown below:

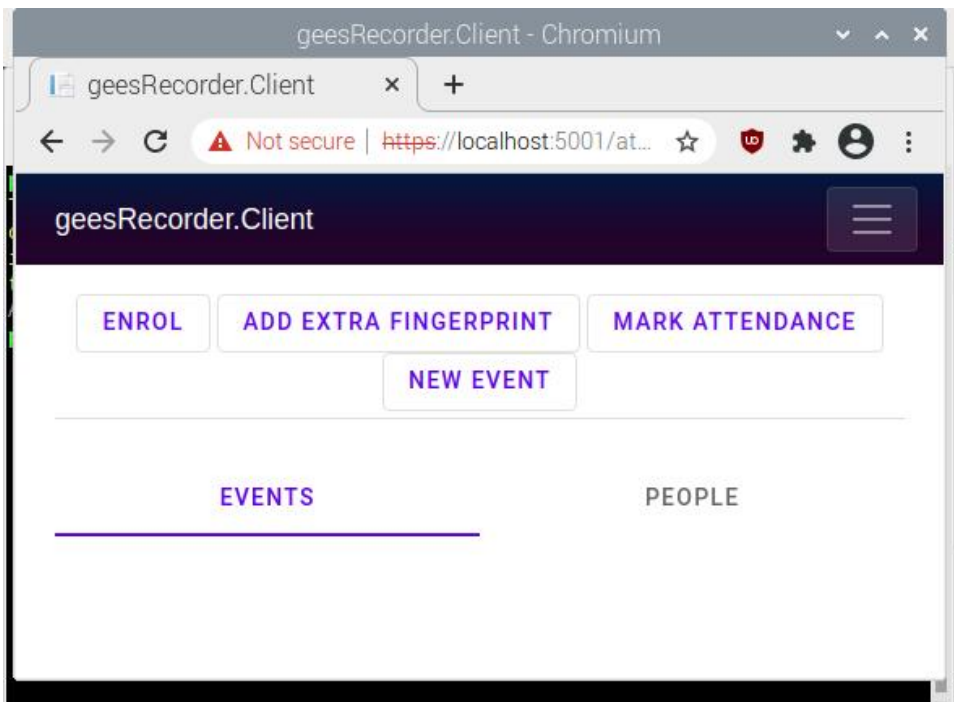

Figure 4.5

As seen above, the dashboard allows the user to enrol attendants, create attendance events and also to switch into attendance marking mode. The enrolment process is a two-step process which involves filling in the attendant's data and then recording the fingerprint through the sensor.

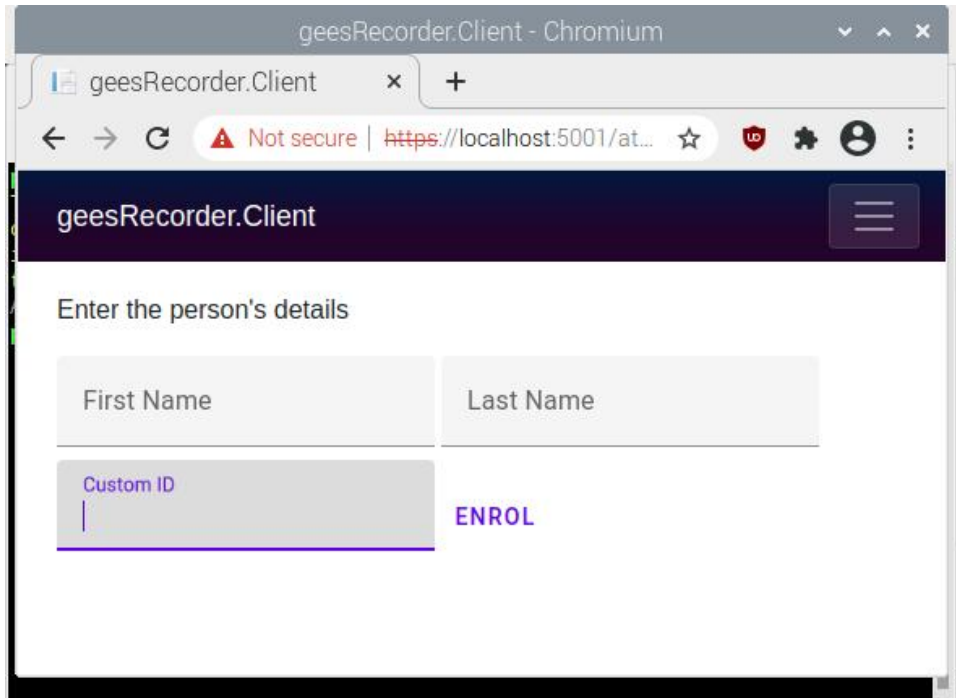

Figure 4.6

Once the details are filled, and the enrol button is clicked, a modal appears instructing the user when to place their fingers on the sensor and when to remove it and enrolment is completed. Upon successful enrolment, an attendant can now mark attendances on events as long as they arrive within the time bounds of the event. Events are created with a Start and End time as shown below:

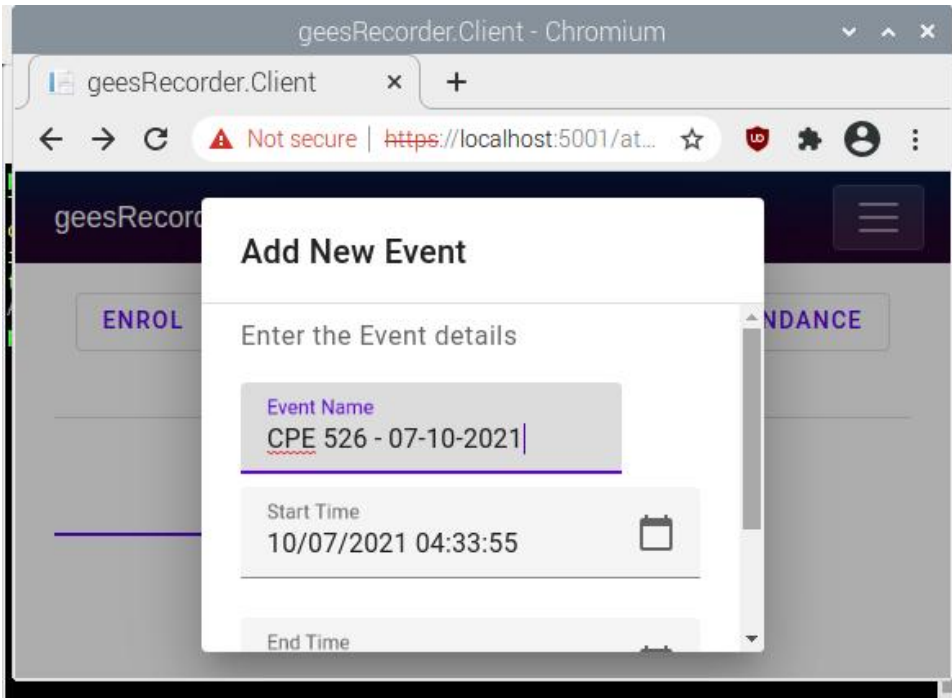

Figure 4.7

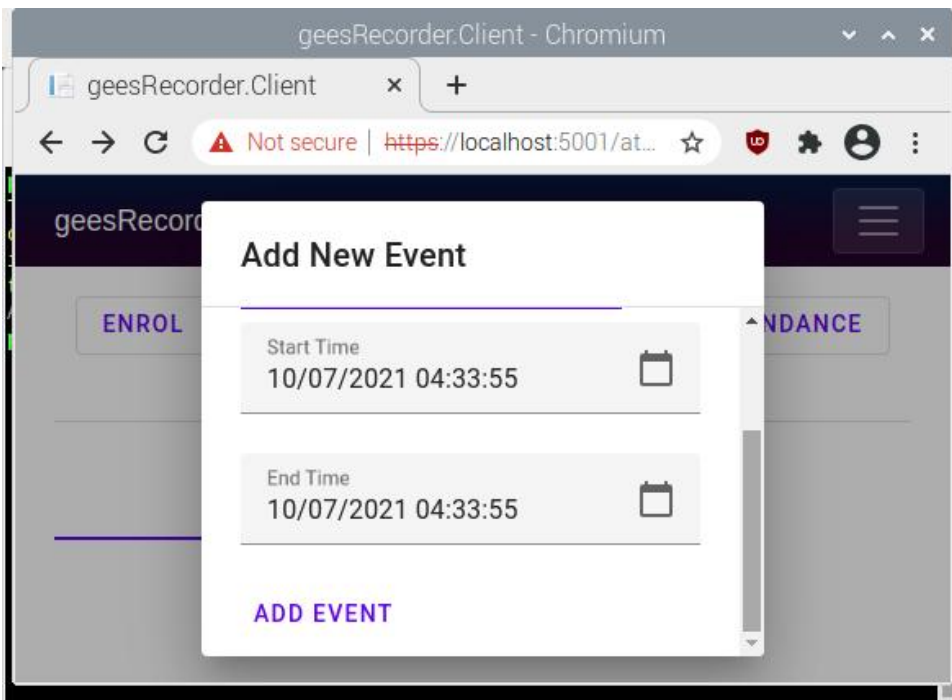

Figure 4.8

The consequence of the creation of an event means that attendants can only mark attendances between the pre-set start time and the end time.

Upon successful enrolment, event creation and marking of attendances, the user has the option of viewing a summary of their attendants as shown below.

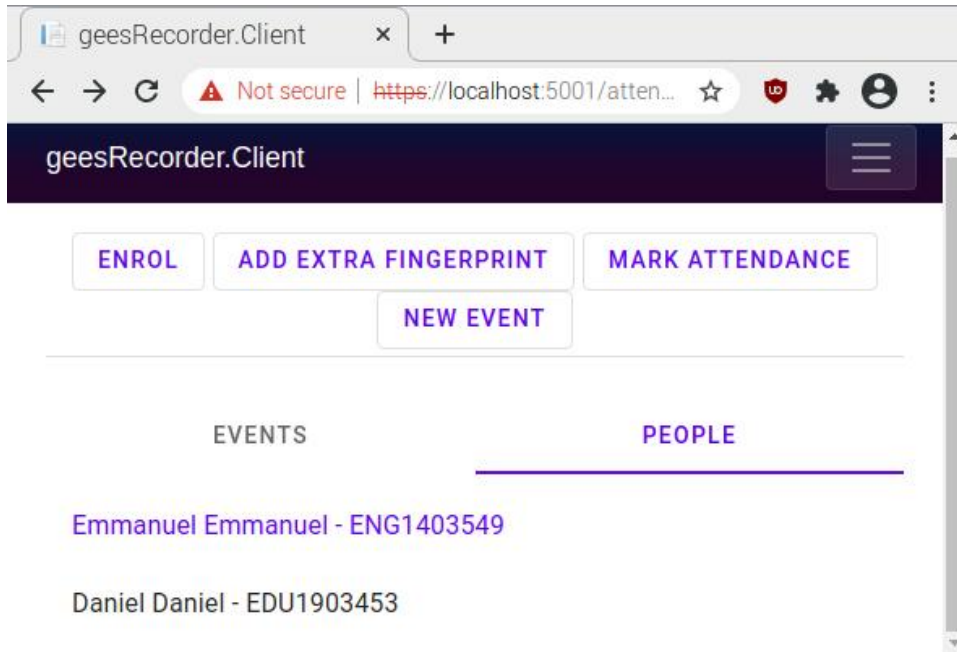

Figure 4.9

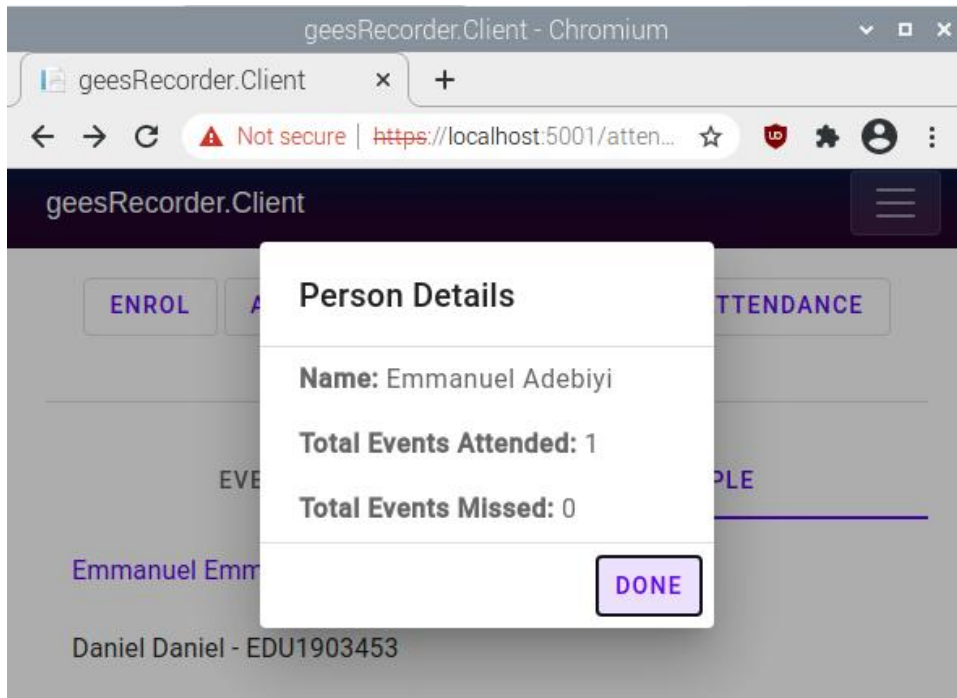

Figure 4.10

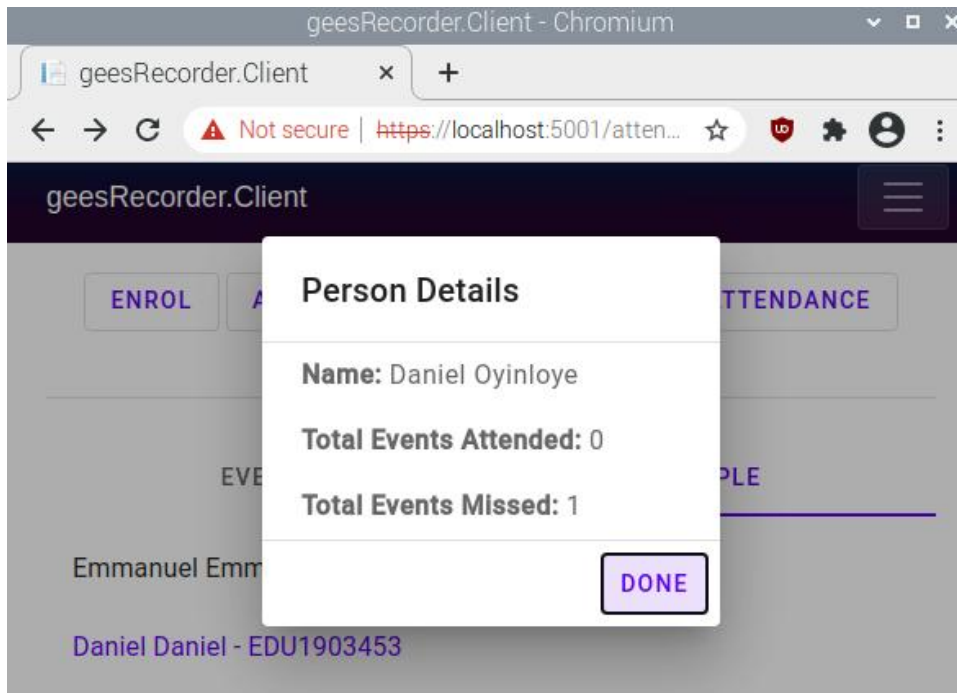

Figure 4.11

On the Data Collation side of things, the user can create a Data Collation project in a similar way. It is shown in the screenshot below:

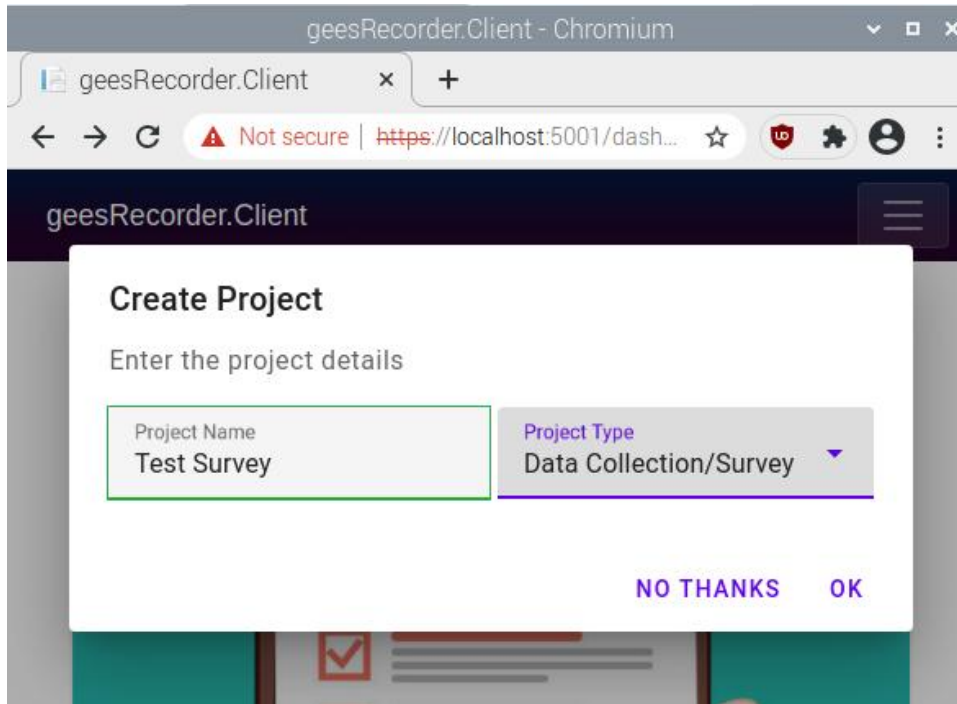
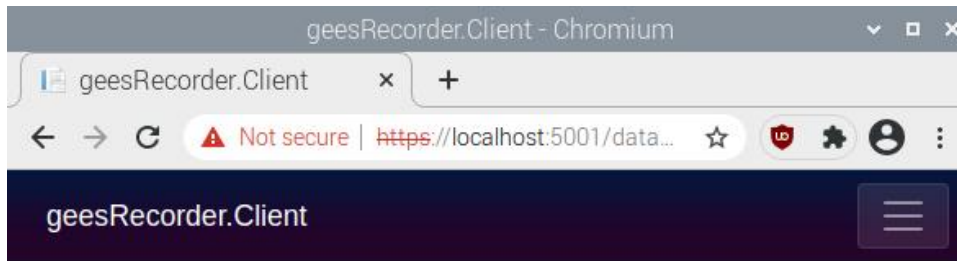

Figure 4.12

Upon Successful creation of the project, the user is required to add questions as shown below:



There are no questions at the moment! Click the button below to add

[ADD QUESTIONS](#)

Figure 4.13

The user can add three different type of questions which are: textual answer, single choice and multiple choice. For the question types with options, the user can add or delete options as they seem fit. The process of creating questions is illustrated below. Figure 4.14 shows a single choice question while Figure 4.15 shows a question that has a text-based answer.

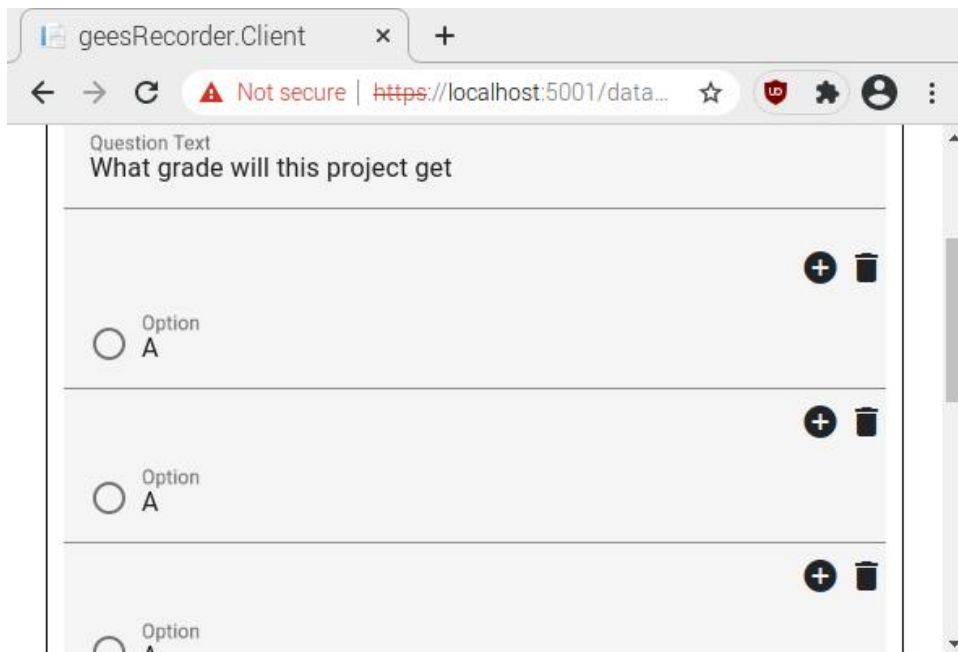

Figure 4.14

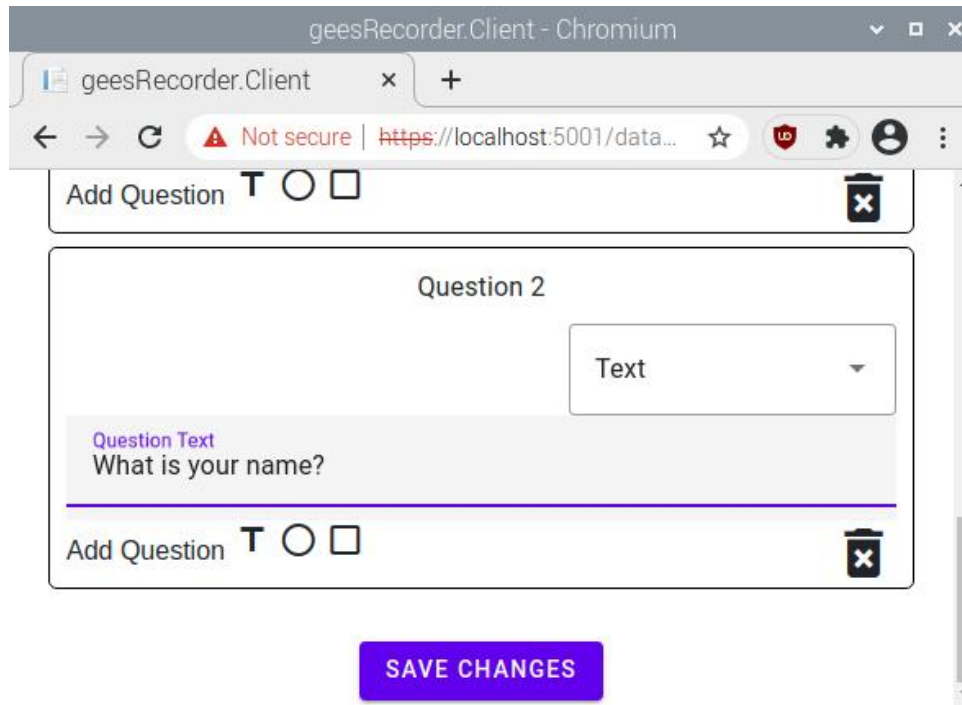

Figure 4.15

Finally, on going back to the project when questions are added, the user gets tons more options as shown below:

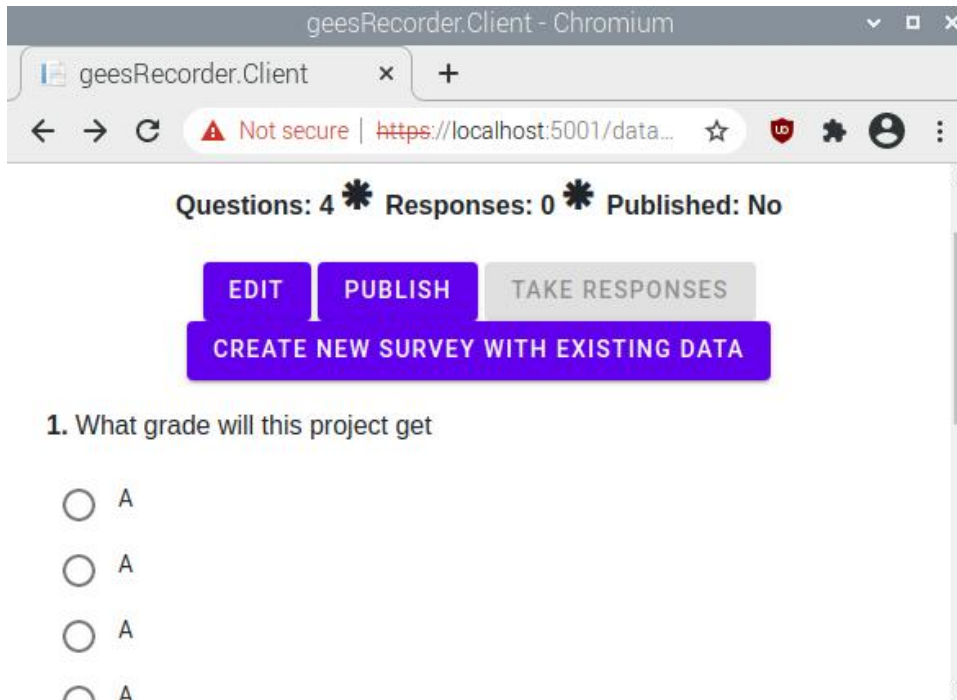

Figure 4.16

As seen above, a brief summary is shown on top, with some actions preceding. The ‘Edit’ option allows the user to add, edit and delete questions. The ‘Publish’ option when clicked disables editing and allow users to start taking responses to the questions. Finally, the “Create New Survey with Existing Data” helps the user create a new unpublished project with the same set of questions.

4.2 - SUMMARY OF RESULTS

The following results were achieved upon the completion of this project:

- Tamper Proof Attendance Register: The device will be expected to allow creation of attendance sheets, enrolment of registrants and allow a fingerprint-based system of attendance marking which will allow attendance marking only within a restricted time frame.
- Attendance Report Generation and Exportation: The device should be able to allow its operator to generate and export data from attendance sheets into standard spreadsheet formats like ‘xlsx’. This will allow further manual processing of the gathered attendance data.
- Flexible Attendance Deadline System: The device will be expected to grant its operators the flexibility of setting internal deadlines for each attendance event. This simply means

that after registrants have successfully marked their attendances within the specified time frame, the operator can still set a deadline to screen out a subset of the registrants.

- **Tamper Proof Data Collection:** The device should allow the creation of survey sheets that can be heavily customised and manually edited based on a user’s need. The device will also allow survey participants to fill out the necessary information on previously created survey sheets.
- **Easy Data Processing:** The device should be able to allow its operator to automatically calculate popular statistical operations like Mean, Standard Deviation etc, on the data collected from surveys.
- **Real Time Data Synchronisation:** The device should automatically synchronise recorded data to online servers whereby its operator can access recorded data on the go without needing physical access to the device.
- **Internet Connection Independence:** The device should feature a local database where it will cache data temporarily while in ‘Offline Mode’. On getting access to the internet, the device should then upload the cached data to the online servers and remove them from its cache.

4.3 - BILL OF ENGINEERING MANAGEMENT AND EVALUATION

The table below shows the approximate cost analysis of the components which were required and used for the successful completion of this project.

Table 4.1.1 - BEME

S/N	COMPONENTS	QUANTITY	UNIT PRICE	TOTAL PRICE
1.	Raspberry Pi 3B	1	₦16,900	₦16,900
2.	7-inch LCD screen	1	₦20,000	₦20,000
3.	Fingerprint Sensor Module	1	₦7,000	₦7,000
4.	Raspberry Pi Compatible Mini	1	₦3,200	₦3,200

	Keyboard			
5.	Power and Packaging		₦8,000	₦8,000
6.	USB UART TTL Converter		₦800	₦800
7.	Transportation and Waybill		₦6,200	₦6,200
GRAND TOTAL				₦70,000

The above implementation while fairly more expensive than traditional and most popular implementation is still relatively cheap for the functionality and performance that it offers.

CHAPTER FIVE

CONCLUSION AND RECOMMENDATION

The implementation of the extensible handheld attendance register and data collation device as shown in this project has led to some remarkable takeaways which shall be discussed briefly in this chapter. The implementation successfully solved the problem of ease of access to data and portability while significantly bring down the cost per unit device in comparison with the

computer-based implementations. Even at that, the approach used for this project is by no means perfect. All of these will be discussed in this chapter.

5.1 - CONCLUSIONS

The following conclusions can be deduced from the results of this project:

- The implementation and production of cheap, portable fingerprint attendance devices is not infeasible.
- Data Collation is not, and should not be confined to traditional methods and(or) web-based solutions as this project successfully implements a hybrid data collation system that is internet dependent and tolerant of network problems, while at the having the advantage of synchronisation over the internet whenever such is possible
- The efficiency of managing attendance with a hybrid system like in this implementation outperforms other approaches with great degrees.
- This implementation is fairly cheaper than the most sophisticated implementations and slightly more expensive than the minimalist solutions. This brings a great degree of flexibility and efficiency at a much lower rate of change in cost
- This implementation allows for easy storage and retrieval of data even after device failure or network failure. This is achieved because of the redundancy introduced by using a. local storage and backing up to a cloud storage hereby massively improving the reliability of the system as a whole.

5.2 - RECOMMENDATIONS

The following listed below are some recommendations or methods of operation that can be improved upon in another implementation of the approach described in this project:

- The cost of the production can be reduced by utilising more minimal components (e.g., a smaller board computer than Raspberry Pi 3B) than that used in this project.
- By utilising more minimal components, the total surface area and volume of the final product reduces hereby increasing portability.
- The approach used in this project is dependent on an external network for internet access. This can be improved by using a built-in module to supply internet.
- Fingerprint storage happens on the chip of the fingerprint sensor, this limits the total number of fingerprints that can be stored. Moving the storage of the scanned prints to the board computer increases the potential number of scanned prints that can be capacity exponentially.
- Another great advantage of moving the storage of the scanned prints to the board computer is the potential increase in speed due to the increased processing power offered by the board computer in comparison with the fingerprint sensor in-chip processor.

REFERENCES

1. Cappelli, R., Maio, D., Maltoni, D., Wayman, J., L. and Jain, A. K. (2006). Performance evaluation of fingerprint verification systems, *IEEE Trans. Pattern Anal.*, 28(1), pp 3-18.

2. Attendance Monitoring System of Students Based on Biometric and GPS Tracking System. J.Chandramohan, R.Nagarajan, M.Ashokkumar, T.Dineshkumar, G.Kannan, R.Prakash. International Journal of Advanced Engineering, Management and Science (IJAEMS) [Vol-3, Issue-3, Mar- 2017] <https://dx.doi.org/10.24001/ijaems.3.3.16>
3. IoT Based Biometric Attendance System. Piyush Devikar, Ajit Krishnamoorthy, Aditya Bhanage, Mohit Singh Chauhan. International Journal of Advanced Research in Computer and Communication Engineering (ICRITCSA). M S Ramaiah Institute of Technology, Bangalore Vol. 5, Special Issue 2, October 2016.
4. An android based course attendance system using face recognition. Dwi Sunaryonoa, Joko Siswantorob, Radityo Anggoro (2018). Journal of King Saud University - Computer and Information Sciences
5. Development of Fingerprint Biometric Attendance System for Non-Academic Staff in a Tertiary Institution Adewole K. S., Abdulsalam S. O., Babatunde R. S., Shittu T. M. and Oloyede M. O (2014). Department of Computer Science, University of Ilorin.
6. Development of Academic Attendance Monitoring System Using Fingerprint Identification. Tabassam Nawaz, Saim Pervaiz, Arash Korrani, Azhar-Ud-Din. (IJCSNS) International Journal of Computer Science and Network Security, VOL.9 No.5, May 2009.
7. <https://www.redcort.com/its-about-time/history-of-time-and-attendance-systems>

APPENDIX

META ANALYSIS TABLE

S/N	AUTHOR	YEAR	TITLE	IMPORTANCE	LIMITATION
1	J.Chandramohan, R.Nagarajan, M.Ashokkumar, T.Dineshkumar, G.Kannan, R.Prakash	2017	Attendance Monitoring System of Students Based on Biometric and GPS Tracking System.	The system needs to be constantly connected to a computer. The data cannot be extracted without physical access. The implementation of the system is heavily reliant on GSM, a service which is oftentimes unreliable	The system needs to be constantly connected to a computer. The data cannot be extracted without physical access. The implementation of the system is heavily reliant on GSM, a service which is oftentimes unreliable
2	Piyush	2016	IoT Based	The stored data is backed	The system is internet

	Devikar, Ajit Krishnamoorthy, Aditya Bhanage, Mohit Singh Chauhan		Biometric Attendance System	up by uploading to an online Google Spreadsheet	dependent. It must be constantly connected to the internet
3	Dwi Sunaryono, Joko Siswanto, Radityo Anggoro	2018	An android based course attendance system using face recognition	The system uses facial recognition which is another popular means of biometric identification of humans. It also uses Android devices which are ubiquitous in many societies reducing the need for the cost of building an extra device	The system is phone dependent (Android). So many factors can make phones unavailable or disallowed for use at different scenarios. Also, as the authors pointed out, the attendance system which requires every student to use a personal phone for the recording of their attendance can easily be cheated as there is no way to ensure students are in class
5	Adewole K. S., Abdulsalam S. O., Babatunde R. S., Shittu T. M. and Oloyede M. O	2014	Development of Fingerprint Biometric Attendance System for Non-Academic Staff in a Tertiary Institution	This system generates monthly attendance reports. It also allows some flexibility for taking 'Time-in' and 'Time-out' attendances.	The system is based on a software program which can only be installed on a computer. This reduces mobility and increases dependence on external power supply
5	Tabassam Nawaz, Saim Pervaiz, Arash Korrani, Azhar-Ud-Din	2009	Development of Academic Attendance Monitoring System Using Fingerprint	The data generated is stored into an SQL Server database which makes it easy for the system to generate reports.	The system is computer based and hence has poor mobility. Also, the system does not identify any way to store miscellaneous attendance related data

			Identification		
--	--	--	-----------------------	--	--

FINGERPRINT ENROLLMENT SCRIPT (PYTHON)

```
import time
import requests
from pyfingerprint.pyfingerprint import PyFingerprint
from pyfingerprint.pyfingerprint import FINGERPRINT_CHARBUFFER1
from pyfingerprint.pyfingerprint import FINGERPRINT_CHARBUFFER2

STATE_POST_URL = 'https://localhost:5001/fingerprint/state'
ID_POST_URL = 'https://localhost:5001/fingerprint/enrol/id'

def format_state_url(statusCode):
    return f'{STATE_POST_URL}?statusCode={statusCode}'

def format_id_url(id,exists):
    return f'{ID_POST_URL}?id={id}&exists={exists}'

## Enrolls new finger

## Tries to initialize the sensor - '/dev/ttyUSB0' - (Linux port)
try:
    f = PyFingerprint('/dev/ttyUSB0', 57600, 0xFFFFFFFF, 0x00000000)

    if ( f.verifyPassword() == False ):
        raise ValueError('The given fingerprint sensor password is wrong!')

except Exception as e:
    print('The fingerprint sensor could not be initialized!')
```

```

print('Exception message: ' + str(e))

requests.post(format_state_url(6), verify=False)

exit(1)

## Gets some sensor information

print('Currently used templates: ' + str(f.getTemplateCount()) + '/' +
      str(f.getStorageCapacity()))

## Tries to enroll new finger

try:
    print('Waiting for finger...')
    requests.post(format_state_url(0), verify=False)

    ## Wait that finger is read
    while ( f.readImage() == False ):
        pass

    ## Converts read image to characteristics and stores it in charbuffer 1
    f.convertImage(FINGERPRINT_CHARBUFFER1)

    ## Checks if finger is already enrolled
    result = f.searchTemplate()
    positionNumber = result[0]

    if ( positionNumber >= 0 ):
        requests.post(format_state_url(3), verify=False)
        requests.post(format_id_url(positionNumber, True), verify=False)

```

```

        print('Template already exists at position #' + str(positionNumber))
        exit(0)
print('Remove finger...')
requests.post(format_state_url(2), verify=False)
time.sleep(2)
requests.post(format_state_url(1), verify=False)
print('Waiting for same finger again...')

## Wait that finger is read again
while ( f.readImage() == False ):
    pass
## Converts read image to characteristics and stores it in charbuffer 2
f.convertImage(FINGERPRINT_CHARBUFFER2)

## Compares the charbuffers
if ( f.compareCharacteristics() == 0 ):
    raise Exception('Fingers do not match')

## Creates a template
f.createTemplate()

## Saves template at new position number
positionNumber = f.storeTemplate()
print('Finger enrolled successfully!')
print('New template position #' + str(positionNumber))

requests.post(format_state_url(5), verify=False)
requests.post(format_id_url(positionNumber, False), verify=False)

```

```
except Exception as e:  
    print('Operation failed!')  
    print('Exception message: ' + str(e))  
  
requests.post(format_state_url(6), verify=False)  
exit(1)
```

Other code files can be found in the source code repository located at <https://github.com/AmSmart/geesRecorder>