

DESIGN OF A SOLAR MONITORING SYSTEM USING AN IOT DEVICE

BY

SULE MOHAMMED ALIU

ENG1708909

ANETOR ASHER

ENG1707880

JOSEPH BENEDICT

ENG1709533

AMENAGHAWON CLINTON

ENG1704161

ONAH CHRISTIAN CHUKWUBUIKEM

ENG1704233

OYEWOLE CHRISTIAN DAMILOLA

ENG1704245

OLUYOH EFEMENA

ENG1604185

SAMUEL MIRACLE EBUBECHUKWU

ENG1704248

DEPARTMENT OF ELECTRICAL AND ELECTRONIC ENGINEERING

FACULTY OF ENGINEERING

UNIVERSITY OF BENIN

SEPTEMBER 2023

DESIGN OF A SOLAR MONITORING SYSTEM USING AN IOT DEVICE

BY

SULE MOHAMMED ALIU

ENG1708909

ANETOR ASHER

ENG1707880

JOSEPH BENEDICT

ENG1709533

AMENAGHAWON CLINTON

ENG1704161

ONAH CHRISTIAN CHUKWUBUIKEM

ENG1704233

OYEWOLE CHRISTIAN DAMILOLA

ENG1704245

OLUYOH EFEMENA

ENG1604185

SAMUEL MIRACLE EBUBECHUKWU

ENG1704248

**A PROJECT SUBMITTED TO THE DEPARTMENT OF ELECTRICAL AND
ELECTRONIC ENGINEERING, FACULTY OF ENGINEERING,
UNIVERSITY OF BENIN, BENIN CITY. IN PARTIAL FULFILMENT OF
THE REQUIREMENT FOR THE AWARD OF A BACHELOR OF
ENGINEERING (B. ENG) IN ELECTRICAL AND ELECTRONIC
ENGINEERING**

SEPTEMBER 2023

CERTIFICATION

This is to certify that this project was carried out by Sule Mohammed Aliu with matriculation number ENG1708909; Anetor Asher with matriculation number ENG1707880; Joseph Benedict with matriculation number ENG1709533; Amenaghawon Clinton with matriculation number ENG1704161; Onah Christian Chukwubuikem with matriculation number ENG1704233; Oyewole Christian Damilola with matriculation number ENG1704245; Oluyoh Efemena with matriculation number ENG1604185; Samuel Miracle Ebubechukwu with matriculation number ENG1704248

.....

.....

PROF. K.O. OGBEIDE

DATE

H.O.D

.....

.....

PROF. K.O. OGBEIDE

DATE

SUPERVISOR

DEDICATION

This project is dedicated to all the innovators and technology enthusiasts who believe in the power of IoT to revolutionize monitoring systems.

ACKNOWLEDGEMENT

Our biggest thanks goes to God Almighty for giving us the strength to start and finish our bachelor's degree in Electrical and Electronic Engineering, University of Benin. With his help, we were able to start and finish this project despite the obstacles encountered.

We would also like to thank our project supervisor, Prof. K.O. Ogbeide for patiently working with us on this project. His knowledge and expertise was a big help as we worked on the project. A big thank you also goes to the Head of Department of Electrical and Electronic Engineering, Prof. K.O. Ogbeide for ensuring that we had what we needed to complete the project.

To all academic and non-academic staff of the Department of Electrical and Electronic Engineering, we say thank you for making our stay here successful. Special thanks goes to our parents and guardians for their encouragement and support throughout our stay in the university. Without them we wouldn't have made it this far. Thank you to our friends who helped during our time of need.

Their loving support saw us through the hurdles we faced.

**Finally, thank you to everyone in the Electrical and Electronic Engineering
Graduating class of 2020/2021 session. The journey was not a smooth one, but we
made it to the end. Congratulations!!!**

TABLE OF CONTENT

Title Page	-	-	-	-	-	-	-	-	-	i
Certification	-	-	-	-	-	-	-	-	-	ii
Acknowledgement	-	-	-	-	-	-	-	-	-	iii
Dedication	-	-	-	-	-	-	-	-	-	iv
Table of Content	-	-	-	-	-	-	-	-	-	v
List of Figure	-	-	-	-	-	-	-	-	-	-
										ix
Acronyms	-	-	-	-	-	-	-	-	-	x
Abstract	-	-	-	-	-	-	-	-	-	xi

CHAPTER ONE: INTRODUCTION

1.0Background of Study	-	-	-	-	-	-	-	-	1
-------------------------------	---	---	---	---	---	---	---	---	----------

1.1 Problem Statement	-	-	-	-	-	-	-	-	3
1.2 Aim	-	-	-	-	-	-	-	-	4
1.3 Objectives	-	-	-	-	-	-	-	-	-
				4					
1.4 Scope of the Project	-	-	-	-	-	-	-	-	4
1.5 Methodology	-	-	-	-	-	-	-	-	5
1.6 Relevance of Work	-	-	-	-	-	-	-	-	6

CHAPTER TWO: LITERATURE REVIEW

2.0 Review of Other Related Works	-	-	-	-	-	-	-	7
2.1 History of Solar Monitoring System-	-	-	-	-	-	-	-	10
2.3 Advantages of Smart PV Monitoring Systems	-	-	-					13

2.4 Field of Application of IOT Based Solar PV

Monitoring Systems	-	-	-	-	-	-	-	13
---------------------------	---	---	---	---	---	---	---	-----------

2.5 Review on Components Used In the Design of

Smart PV Monitoring System with IOT	-	-	-	-	-	-	15
--	---	---	---	---	---	---	-----------

2.5.1 Humidity and Temperature Sensor (DHT11)	-	-	-	-	-	15
--	---	---	---	---	---	-----------

2.5.1.1 Features of Humidity and Temperature Sensor (DHT11)	-	-	-	-	-	17
--	---	---	---	---	---	-----------

2.5.2 Microcontroller Unit ESP32 Nodemcu	-	-	-	-	-	18
---	---	---	---	---	---	-----------

2.5.3 LCD Display; LCD1 LM016L	-	-	-	-	-	19
---------------------------------------	---	---	---	---	---	-----------

2.5.4 Voltage Regulator; U1 7805	-	-	-	-	-	-	21
---	---	---	---	---	---	---	-----------

2.5.5 Light Sensor R2 LDR	-	-	-	-	-	-	23
----------------------------------	---	---	---	---	---	---	-----------

2.5.6 PV Module	-	-	-	-	-	-	24
------------------------	---	---	---	---	---	---	-----------

2.5.6.1 Types of Solar Panels	-	-	-	-	-	25
--------------------------------------	---	---	---	---	---	-----------

2.5.6.1.1 Monocrystalline Solar Panels	-	-	-	-	-	25
2.5.6.1.2 Polycrystalline Solar Panels	-	-	-	-	-	26
2.5.6.1.3 Thin Film Solar Panels	-	-	-	-	-	27
2.5.7 Voltage Sensor LM358	-	-	-	-	-	29
2.5.8 Printed Circuit Board	-	-	-	-	-	31
2.6 Designing a Remote Monitoring Solar Power System	-	-	-	-	-	33
2.7 Block Diagram Showing Design Methodology	-	-	-	-	-	35

CHAPTER THREE: DESIGN METHODOLOGY

3.1 Design of Voltage Sensing Circuit	-	-	-	-	-	36
3.2 Design of the Buck-Converter or Voltage Regulator Sub-Circuit	-	-	-	-	-	36
3.3 Design of the LDR Sub-Circuit	-	-	-	-	-	38

3.4 Design of the DHT11 Sub Circuit	-	-	-	-	-	-	-	-	39
3.5 Design of the LCD Sub-Circuit	-	-	-	-	-	-	-	-	40
3.6 Solar Panel Selection	-	-	-	-	-	-	-	-	41
3.6.1Solar Panel Parameters	-	-	-	-	-	-	-	-	41
3.7Design of the Web Software	-	-	-	-	-	-	-	-	42
3.8. Circuit Diagram	-	-	-	-	-	-	-	-	-
									44
3.9Working Principle of the Circuit	-	-	-	-	-	-	-	-	45

CHAPTER FOUR: CONSTRUCTION, TESTING AND RESULT

4.1.Construction	-	-	-	-	-	-	-	-	-	47
4.1.1Soldering	-	-	-	-	-	-	-	-	-	48
4.1.2 Coupling	-	-	-	-	-	-	-	-	-	48

4.1.3 Casing	-	-	-	-	-	-	-	-	-	48
4.2. Installation	-	-	-	-	-	-	-	-	-	49
4.3 Testing and Results	-	-	-	-	-	-	-	-	-	49
4.4 Discussion and Findings	-	-	-	-	-	-	-	-	-	56
4.5 Bill of Engineering Measurement and Evaluation	-	-	-	-	-	-	-	-	-	-

CHAPTER FIVE: CONCLUSIONS AND RECOMMENDATIONS

5.1 Conclusion	-	-	-	-	-	-	-	-	-	60
5.2 Recommendations	-	-	-	-	-	-	-	-	-	61
References	-	-	-	-	-	-	-	-	-	62
Appendix	-	-	-	-	-	-	-	-	-	64

LIST OF FIGURE

Figure 2.1 A DHT11 sensor	-	-	-	-	-	-	-	17
Figure 2.2 The ESP32 Microcontroller	-	-	-	-	-	-	-	
								18
Figure 2.3 LCD1 LM016L	-	-	-	-	-	-	-	21
Figure 2.4 Voltage Regulator; U1 7805	-	-	-	-	-	-	-	
								22
Figure 2.5 An LDR R2 Light Sensor	-	-	-	-	-	-	-	24
Figure 2.6 – Monocrystalline Solar Panel	-	-	-	-	-	-	-	
								26
Figure 2.7- Polycrystalline Solar Panel	-	-	-	-	-	-	-	27
Figure 2.8- Thin Film Solar Panel	-	-	-	-	-	-	-	
								27

Figure 2.9 LMC358	-	-	-	-	-	-	-	-	-
									31
Figure 2.10 A typical PCB	-	-	-	-	-	-	-	-	-
									32
Figure 2.11 Block Diagram Showing Design Methodology	-	-	-	-	-	-	-	-	35
Figure 3.1 Voltage Sensor Circuit.	-	-	-	-	-	-	-	-	-
									36
Figure 3.2 Buck Converter circuit	-	-	-	-	-	-	-	-	-
									38
Figure 3.3 LDR Sub-Circuit	-	-	-	-	-	-	-	-	39
Figure 3.4 DHT11 Sub-Circuit	-	-	-	-	-	-	-	-	40
Figure 3.5 LCD Sub-Circuit	-	-	-	-	-	-	-	-	40
Figure 3.6 Flow Chart Illustrating the Web Design Software	-	-	-	-	-	-	-	-	-
									43

Figure 3.7 Circuit Diagram of A Remote PV Monitoring System -	-	43
Figure 4.1. 6 X 6 Inch Casing -	- - - - -	48
Figure 4.2 Installation of the device and solar panel -	- - -	49
Figure 4.3: Graphical Representation of voltage verses humidity	-	-
		52
Figure 4.4: Graphical Representation of Voltage against Time	-	-
		53
Figure 4.5: Graphical Representation of temperature verses time	-	-
		54
Figure 4.6: Graphical Representation of time, voltage and luminance	-	-
		55
Figure 4.7: Graphical Representation of Time, Voltage and Humidity	-	56

ACRONYMS

AC	-	Alternating Circuit
ADC	-	Analogue to Digital Converter
DC	-	Direct Circuit
EPC	-	Engineering Procurement and Constriction
HTTP	-	Hyper Text Transfer Protocol
IC	-	Integrated Circuit
IOT	-	Internet of Things
LCD	-	Liquid Crystal Display
LDR	-	Light Dependent Resistor
LED	-	Light Emitting Diode
LPWAN	-	Lower Power Wide Area Network

MCU	-	Micro Controller Unit
MQTT	-	Message Queening Telemetry
N	-	Photo Voltaic
NB	-	Narrow Band
LRAWAN	-	Low Range Wide Area Network
OP	-	Operational Amplifier
PCB	-	Printed Circuit Board
PLC	-	Programmable Logic Controller
RH	-	Relative Humidity
SEIA	-	Solar Energy Industry Data
TN	-	Twisted Nematic

ABSTRACT

This project focuses on designing a monitoring system using an Internet of Things (IoT) device that sends data to Thingspeak, a cloud-based platform. Solar system are affected by various factors such as temperature, weather condition and light intensity, on their output performance. These factors can lead to inefficient performance, increased maintenance cost and so on. Therefore, the aim of the project is to design and implement an intelligent virtual monitoring system that utilizes IoT to monitor PV solar panel array.

To achieve this work, the role was centred on light sensor, voltage sensor and temperature sensor. These sensors are connected to an IoT gateway or a local data acquisition unit that acts as a bridge between the sensors and the internet collects the sensors data and prepares it for transmission to the cloud.

Testing the monitoring system works satisfactorily. Having humidity of 85g/m³ on average, voltage of 35.78V during the day and 0V at night, temperature as high as 30°C and low as 27°C and luminance of 4201cd/m² during the day and 0cd/m² at night.

CHAPTER ONE

INTRODUCTION

1.0 BACKGROUND OF THEB STUDY

The increasing demand for renewable energy has led to the development of solar power systems as an alternative source of electricity. However, the efficiency of these systems is greatly influenced by the environment in which they are installed. To address this challenge, an IoT-based solar power monitoring system was designed and implemented to monitor the performance of a solar power system in real-time (Gaurav Khambakal et al. 2018)

Solar energy is increasingly becoming a crucial part of our energy policies, but there are concerns about the reliability and resiliency of PV power systems. Researchers are working on eliminating the intermittent nature of solar energy production caused by weather conditions and shading effects. Real-time monitoring systems that measure irradiance, temperature, power, voltage, and current are helping to improve the performance and maintenance of PV systems. These systems offer more accurate data and help detect faults, ensuring optimal system performance. Additionally, they provide a historical record of operating parameters for analysis and optimization. (Punduko, D. et al, 2017). These data can be used for later analysis and data mining for more effective PV installation and operation.

The Internet of Things (IoT) is a network where various devices, machines, objects, and even people with unique identifiers can communicate and share data without direct human or computer interaction. This connectivity allows physical objects to be

remotely controlled through internet services, bridging the gap between the physical and virtual worlds.

The Internet of Things (IoT) allows for communication between machines, people, and even combines both. This is made possible through smart sensors integrated into wireless sensor networks, using miniaturization and nanotechnologies. Continuous intelligent remote monitoring of PV systems can help overcome challenges faced by technicians responsible for monitoring and maintaining isolated systems. By reviewing IoT technologies and hardware modules, the most suitable components can be selected for effective communication, speed, and accuracy in monitoring PV power systems. (Stoichkov V. et al, 2016).

1.1 PROBLEM STATEMENT

The increasing global demand for solar energy consumption have raised the problem of reliability of solar systems viz a viz the various components of the solar power systems. In the hearts of these are the solar PV cells which are mostly installed in places not easily accessible as other components of the system. Localities where solar energy systems is used as an alternative for lack of or inadequate supply of electrical grid infrastructure, are faced by huge cost of the solar system which lead to the abandonment of the idea of remote monitoring. Major challenges facing solar power systems include temperature, light intensity and weather conditions, on their performance. For instance, high temperature can reduce the efficiency of solar panel, while fluctuations in light intensity and weather conditions can also impact the system's output. These factors can lead to suboptimal performance, reduced power output, and increased maintenance costs, ultimately making it challenging for solar

power systems to be a viable and cost-effective alternative to traditional energy sources. To this end, monitoring systems have been developed and advanced to measure and enhance the output of solar power systems.

1.2 AIM

The aim of this research work is to design and implement an intelligent virtual monitoring system that utilizes Internet of Things (IoT) in monitoring a PV solar panel array.

1.3 OBJECTIVES

The specific objectives of this research work are as follows:

- i. design a remote monitoring solar power system
- ii. integrate the monitoring system with an LCD display, mobile web using Thingspeak.com, and a computer screen to provide users with data visualization and monitoring options.
- iii. Optimize performance of solar power system by providing real-time monitoring and data visualization, ultimately improving their efficiency and reliability.
- iv. Enable scalability of the monitoring system, allowing it to be adapted to monitor multiple solar power systems of varying sizes and applications.

1.4 SCOPE OF THE PROJECT

This research covers four, 320 Watts, 24 volts mono-crystalline solar photovoltaic (PV) cell monitoring system.

1.5 METHODOLOGY

Data Acquisition: The sensors collect data such as solar radiation levels, temperature, energy output, and other relevant parameters. This data is typically in analog form and needs to be converted into digital signals.

Sensor Connectivity and Sensor Deployment: Connect the sensors to an IoT gateway or a local data acquisition unit. This unit acts as a bridge between the sensors and the Internet. It collects sensor data and prepares it for transmission into the cloud.

Also, deploy sensors in strategic locations to gather data related to solar energy generation and system performance. These sensors can include solar irradiance sensors, temperature sensors, current and voltage sensors, and energy meters.

Data Transmission and Cloud Storage and Processing: The use of wireless communication technologies such as WiFi, cellular networks, or Low-Power Wide-Area Network (LPWAN); and protocols like Low Range Wide Area Network (LoRaWAN) to transmit collected data from data acquisition unit into the cloud. The collected data is then sent to a server for storage and further processing. The cloud platform provides a scalable and secure infrastructure for data storage and analysis.

Data Analysis/Visualization: Utilize data analytic technique to analyze the collected data and extract insights regarding solar energy generation, system performance, and anomalies. Visualization tools can be employed to present the data in a user-friendly format, such as charts, graphs, and dashboards.

Integration with Other Systems: Integrate the solar monitoring system with other enterprise systems, such as energy management systems, billing systems, or asset management systems, to enable seamless data exchange and holistic monitoring and management.

1.6 RELEVANCE OF WORK

The project is focused mainly on the applications of smart PV cell performance monitoring systems that utilizes IoT in providing real time data that shows both ambient and working condition of the PV cells.

Hence it is able to predict the performance of the PV cells as a standalone and in a grid. In this project we are going to monitor photovoltaic cells such as temperature, irradiance, output Voltage and current. These data would be transmitted to a cloud-based server where it can be accessed by authorized personnel.

CHAPTER TWO

LITERATURE REVIEW

2.0 REVIEW OF OTHER RELATED WORKS

The research study by S. George et al., titled "solar power monitoring and control system using Internet of Things (IoT)," focuses on the progress and application of an IoT-based monitoring and control system for solar power generation. The authors highlight the increasing importance of solar power generation and the need for efficient monitoring and control systems to optimize its performance and ensure reliable operation.

Also, the authors proposed an approach for monitoring and controlling solar power systems. They discuss the integration of various sensors like solar irradiance sensors, temperature sensors, and energy meters, to capture data related to solar energy generation, environmental conditions, and energy output.

Their study emphasizes the use of Internet of Things technology to enable real-time monitoring of data collection from the sensors. The collected data is transmitted to a central monitoring system through wireless communication protocols, such as WiFi or cellular networks. A server platform is utilized for storage, processing, and analysis of data. The authors highlight the benefits of server storage in terms of its scalability, accessibility and remote monitoring capabilities.

Data analytics techniques are employed to analyze the collected data and derive useful insights regarding system performance, energy generation, and potential faults or anomalies. This enables proactive maintenance and optimization of solar power

system. The authors also discuss the implementation of control mechanisms through the IoT platform. This allows for remote control of connected devices, such as inverters or switches, to manage and optimize the operation of the solar power system. Their study emphasizes the importance of a user-friendly interface for effective system management. Visualization tools, such as charts, graphs, and dashboards, are employed to present the monitored data in a comprehensible manner.

Furthermore, the paper addresses the issue of security in IoT-based solar monitoring and control systems. It discusses the need for secure data transmission, authentication mechanisms, and access control to protect the system from unauthorized access or tampering. Overall, the research presents an IoT-based solution for solar power monitoring and control, highlighting the integration of sensors, data acquisition, cloud-based storage and analysis, control mechanisms, and security considerations. The proposed system offers potential benefits in terms of enhanced monitoring, improved performance, and remote management of solar power generation.

Another study by N. Zamora et al., titled "Internet of Things Applied to Photovoltaic Solar Energy Generation Systems" provides an overview of the application of the Internet of Things (IoT) in photovoltaic solar energy generation systems.

The authors begin by discussing the increasing deployment of IoT technologies in various industries and emphasizes the potential benefits of applying IoT in the solar energy sector. It highlights that IoT can enhance the monitoring, control, and maintenance of photovoltaic (PV) solar systems.

The authors then delve into the different aspects of IoT implementation in solar energy systems. They discuss the deployment of sensors to capture data related to solar irradiance, temperature, energy output, and other relevant parameters. These sensors enable real-time monitoring and data collection, which can be further analyzed for performance optimization and fault detection.

The study emphasizes the importance of reliable data communication and transmission in IoT-enabled solar monitoring systems. It explores various communication protocols such as Wi-Fi, cellular networks, and LPWAN technologies like LoRaWAN and NB-IoT that facilitate the transfer of data from sensors to a central monitoring system or cloud platform.

Cloud-based platforms play a crucial role in IoT-based solar monitoring. The authors highlight the benefits of cloud storage and processing for scalable data storage, advanced analytics, and visualization of solar energy system performance. They discuss the use of data analytics techniques to extract valuable insights from the collected data, enabling better decision-making and system optimization.

Finally, the authors also address the importance of system management and control in IoT-enabled solar monitoring systems. They discuss the potential for remote monitoring, configuration, and firmware updates of the solar energy system through the IoT platform. This enables proactive maintenance, troubleshooting, and optimization of system performance.

Overall, the study provides a comprehensive review of the application of IoT in photovoltaic solar energy generation systems. It covers key aspects such as sensor deployment, data acquisition and transmission, cloud-based analytics, system management, and security considerations. The insights presented in the paper can help guide future research and development in this field.

2.1 HISTORY OF SOLAR MONITORING SYSTEM

The history of solar monitoring systems can be traced back to the early days of the space program. NASA developed the first solar monitoring system for its satellites in the 1950s and 1960s. These early systems were designed to measure the intensity and variability of solar radiation in space. As solar technology developed and became more accessible, solar monitoring systems were developed for terrestrial applications. In the 1970s and 1980s, solar monitoring systems were primarily used in the scientific community to study the behavior of the sun and its effects on the Earth's atmosphere. In the 1990s and 2000s, solar monitoring systems began to be used more widely in the solar industry. These systems were used to monitor the performance of solar panels, track the movement of the sun, and optimize the efficiency of solar power systems. Today, solar monitoring systems are an essential part of the solar industry. It is used to monitor the performance of solar panels and to ensure that they are working at maximum efficiency. Solar monitoring systems are also used to track the movement of the sun and to optimize the placement of solar panels for maximum energy production. Solar monitoring systems have come a long way since their early days in the space program. Today's systems are highly advanced and can provide detailed information about solar radiation panels.

The discovery of solar cells in the 19th century was the start of a big change in how we produce energy. Researchers have been working on improving solar energy ever since, and it's still ongoing. Solar energy has progressed incredibly fast and is now a major player in the shift towards cleaner energy sources. In the last decade, the solar panel industry has grown by more than 35% on average, and it's expected to keep growing as we move towards renewable energy.

One significant development is that solar panels have become more powerful, going from 250 watts to 500 watts in the past decade. This means that the cost of the panels relative to the overall solar system cost has gone down. Right now, silicon-based solar cells are the most common, but it will take some time for newer types to become dominant. The main challenge is making solar panels cheaper and more efficient, especially for silicon-based ones.

When it comes to solar energy, we're also getting close to the best we can do with current technology. So, researchers are looking into tandem technologies that can improve efficiency. However, making them affordable for everyone will require more research and development.

Another important development is the Internet of Things (IoT), which allows us to remotely monitor and control objects through the internet. This has many applications in renewable energy, like smart cities, villages, and solar streetlights. Renewable energy is growing faster than ever before.

We're also using technology like Raspberry Pi to monitor solar energy usage online. This helps us track how much renewable energy we're using and analyze its impact on our electricity needs. As traditional energy sources like coal and nuclear power have drawbacks, we'll increasingly rely on renewable energy in the future due to its lower environmental impact and cost-effectiveness.

2.3 ADVANTAGES OF SMART PV MONITORING SYSTEMS

1. Easily access and interact with important data in real-time to help achieve business goals.
2. Use past data from solar plants to make important decisions quickly.
3. See energy information from all solar grids on any device, wherever you are.
4. Get clear, real-time information about how well solar assets are doing, like their performance and maintenance status.
5. Stay updated in real-time about important events at solar power plants and understand their impact on operations, finances, and the environment.

2.4 FIELD OF APPLICATION OF IoT BASED SOLAR PV MONITORING SYSTEMS

The Internet of Things (IoT) has made it possible to create lightweight solar cells that can be put on rooftops and vehicles. This allows homeowners and other solar investors to use the sun's energy and not rely on local utility companies. IoT technology is getting smarter and more user-friendly. It uses a combination of software, network connections, and sensors to help solar systems collect, monitor, and share information.

With IoT-based solar panel tracking, we can simulate and improve performance online. It helps us do things like prevent problems, figure out why something went wrong, and where it happened.

Not only that, but companies that provide solar services and power suppliers can manage their solar energy better with IoT. This gives them useful information to make decisions based on data. They can also study how people use power by looking at the data from IoT. The IoT monitoring system is important because it helps us see how well solar panels are working and how much energy they're making. Users can see real-time data, look at past information, compare different trends, and even create graphs. If there's a problem, the system can send a notification by SMS or email.

2.5 REVIEW ON COMPONENTS USED IN THE DESIGN OF SMART PV MONITORING SYSTEM WITH IoT

- Humidity and Temperature sensor (DHT11)
- Microcontroller unit ESP32 NodeMCU
- LCD display; LCD1 LM016L
- Voltage regulator; U1 7805
- LED-GREEN D1
- Battery BAT2 9V
- Light sensor; R2 LDR
- PV Module CCT002
- Resistors

- Capacitors
- Voltage sensor; LM358

2.5.1 HUMIDITY AND TEMPERATURE SENSOR (DHT11)

The DHT11 is a popular and cost-effective sensor used to measure humidity and temperature in various applications. Characteristics of the DHT sensor includes:

Humidity Measurement: The DHT11 sensor can measure relative humidity (RH) within a range of 20% to 90% with an accuracy of approximately $\pm 5\%$.

Temperature Measurement: It can measure temperature within a range of 0°C to 50°C with an accuracy of approximately $\pm 2^{\circ}\text{C}$.

Sensor Technology: The DHT11 utilizes a resistive humidity sensor and a temperature sensing component. These sensors are combined into a single module, making it compact and easy to use.

Digital Output: The DHT11 provides digital output, meaning it communicates with a microcontroller or other devices using a single wire protocol. It uses a proprietary protocol to transmit the measured data.

Low Power Consumption: The DHT11 operates on low power, making it suitable for battery-powered applications or systems with power constraints.

Sampling Rate: The DHT11 has a limited sampling rate, typically around 1 reading per 2 seconds. This slower sampling rate should be considered in applications that require frequent or rapid measurements.

Single-Wire Interface: The DHT11 sensor uses a single-wire interface for both data transmission and power supply, simplifying the wiring and reducing the required pins on a microcontroller.

Limitations: While the DHT11 is a cost-effective sensor, it has some limitations compared to more advanced sensors. It has lower accuracy and a more limited measurement range than some higher-end humidity and temperature sensors. Additionally, it may be more susceptible to environmental factors such as condensation and extreme temperatures.

Applications: The DHT11 sensor finds applications in various fields such as home automation, weather monitoring, HVAC systems, agriculture, and indoor climate control.

2.5.1.1 FEATURES OF HUMIDITY AND TEMPERATURE SENSOR (DHT11)

The important features of the humidity and temperature sensor (DHT11) are listed below.

- It works with a power supply and connections between 3 to 5 volts.
- When it's collecting data, it uses a maximum of 2.5 milliamperes of current.
- It's good at measuring humidity between 20% and 80% and is accurate within 5%.
- It's also good at measuring temperatures between 0 and 50 degrees Celsius, and its accuracy is within plus or minus 2 degrees.
- It can collect data up to once every second, so it's not super fast.
- The sensor is small, with dimensions of 15.5mm x 12mm x 5.5mm.
- It has 4 pins with a spacing of 0.1 inches.

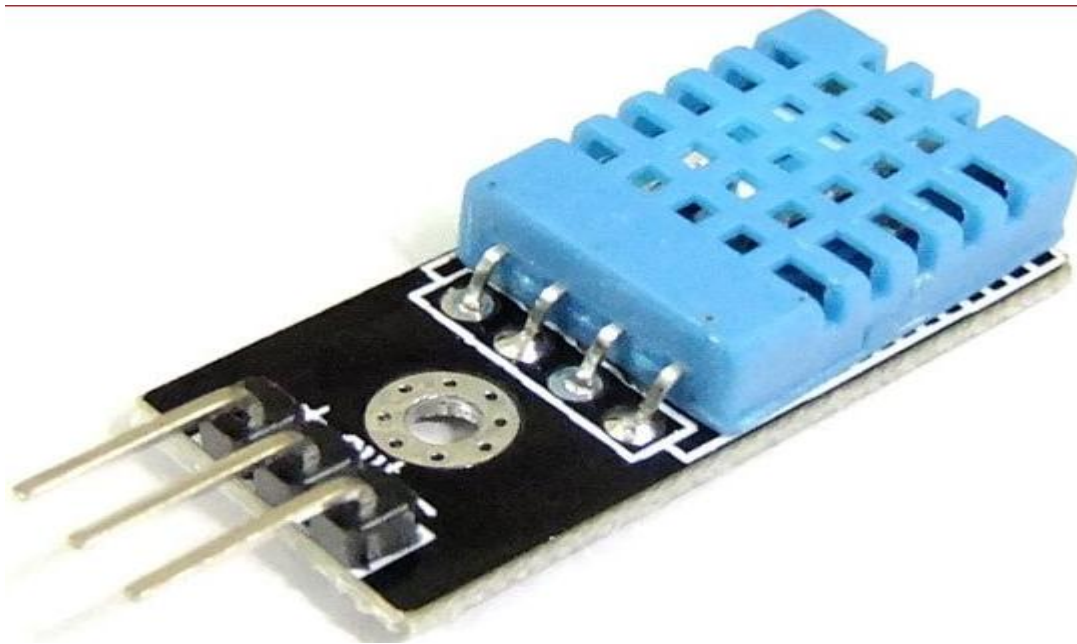

Figure 2.1 A DHT11 sensor

2.5.2 MICROCONTROLLER UNIT ESP32 NODEMCU

The ESP32 NodeMCU is a popular microcontroller development board that is based on the ESP32 system-on-a-chip (SoC). NodeMCU is an open-source firmware based on Lua that runs on the ESP32 microcontroller. The ESP32 is a powerful microcontroller that has built-in WiFi and Bluetooth capabilities. NodeMCU makes it easy to develop IoT applications with the ESP32.

The ESP32 is a powerful microcontroller that has built-in WiFi and Bluetooth capabilities. NodeMCU makes it easy to develop IoT applications with the ESP32.

The ESP32 microcontroller cores are typically clocked at 160 MHz. However, it can be overclocked up to 240 MHz for increased processing power.

Furthermore, the ESP32 NodeMCU includes a built-in ADC that enables analog voltage measurements, making it suitable for applications that require analog sensing.

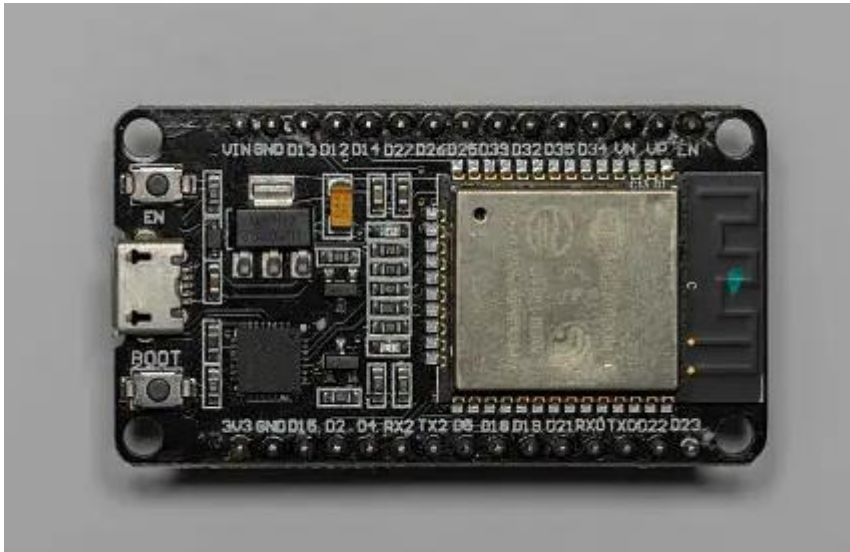

Figure 2.2 The ESP32 Microcontroller

2.5.3 LCD DISPLAY; LCD1 LM016L

The LCD1 LM016L is a 16x2 character LCD display that is compatible with the Hitachi HD44780 controller. It has a single power supply of +5V and can be interfaced with a variety of microcontrollers using either 4-bit or 8-bit mode.

The LCD1 LM016L is a commonly used 16x2 alphanumeric LCD (Liquid Crystal Display) module. Here are some key features and characteristics of the LCD1 LM016L:

Display Size: The LCD1 LM016L has a display size of 16 characters per line and 2 lines, resulting in a total of 32 characters that can be displayed.

Character Set: It supports a standard character set, typically including uppercase letters, lowercase letters, numbers, symbols, and some special characters.

Display Technology: The LCD1 LM016L uses the twisted nematic (TN) LCD technology, which is a common LCD technology known for its low power consumption and readability in most lighting conditions.

Backlight: The module is typically equipped with an LED backlight that provides illumination to the display for better visibility in low-light environments. The backlight can be controlled separately from the display itself.

Interface: The LCD1 LM016L typically uses a parallel interface, which requires several data lines and control signals for communication with a microcontroller or other devices.

Power Supply: The module usually operates on a +5V power supply, although some versions may support a wider voltage range.

Character Size and Format: The module supports a fixed character size, typically 5x8 dots, where each character is composed of 5 columns and 8 rows of dots.

Controller: The LCD1 LM016L is often based on the HD44780 controller or a compatible equivalent. The controller handles the low-level communication with the display, simplifying the software interface with the microcontroller.

Command Set: The module supports a set of commands that can be sent from the microcontroller to control the display, such as positioning the cursor, clearing the display, and controlling the backlight.

Applications: The LCD1 LM016L is commonly used in various applications, including embedded systems, digital meters, industrial control panels, consumer electronics, and other projects where a simple alphanumeric display is required.

It's important to note that the specific features and pin assignments of the LCD1 LM016L module may vary depending on the manufacturer and the specific version of the module. Therefore, it is recommended to refer to the datasheet or documentation provided by the manufacturer for accurate and detailed information.

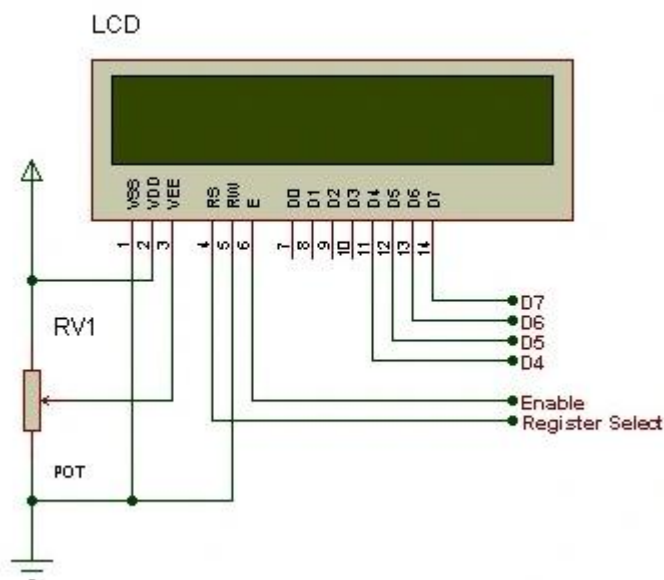

Figure 2.3 LCD1 LM016L

2.5.4 VOLTAGE REGULATOR; U1 7805

The voltage regulator U1 7805 is a popular integrated circuit (IC) that provides a fixed output voltage of +5 volts. Here are some key features and characteristics of the 7805 voltage regulator:

The 7805 is a fixed voltage regulator, meaning it generates a stable output voltage of +5 volts regardless of changes in the input voltage or load conditions. The input voltage range of the 7805 typically extends from 7 volts to 35 volts. However, it is important to note that the input voltage must be at least 2 volts higher than the desired output voltage of +5 volts.

Also, The 7805 can deliver a maximum output current of 1 ampere (A). It is crucial to ensure that the load current does not exceed this limit to prevent overheating and potential damage to the IC.

The 7805 includes built-in thermal overload protection. If the temperature of the IC exceeds a certain threshold, it will automatically reduce the output current or shut down to prevent damage.

It is a three-terminal device with pins for input voltage (V_{in}), ground (GND), and output voltage (V_{out}). The pin configuration may vary slightly depending on the manufacturer and package type.

Finally the 7805 has good voltage regulation, which means it maintains a stable output voltage even when the input voltage or load changes. The regulation is typically within a few percentage points.

The 7805 voltage regulator is commonly used in a wide range of electronic circuits and projects to provide a regulated +5V supply. It is frequently employed in microcontroller-based systems, digital circuits, and low-power electronics.

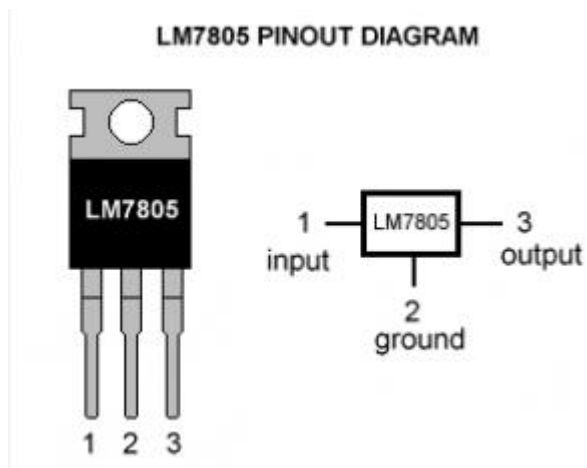

Figure 2.4 Voltage Regulator; U1 7805

2.5.5 LIGHT SENSOR R2 LDR

An LDR, also known as a photoresistor or light-dependent resistor, is a type of semiconductor component whose resistance changes based on the amount of light falling on it. When exposed to light, the resistance of the LDR decreases, and when in darkness, the resistance increases. This property makes LDRs useful for light sensing applications.

In electronic circuits, the LDR is often used as part of a voltage divider configuration, along with a fixed resistor (in this case, "R2"), to create a voltage output that varies with the light intensity.

The circuit works as follows:

1. There is a Light Dependent Resistor (LDR) connected to the transistor's base.

2. A resistor labeled R1 is connected between the positive power supply and the base of the transistor.
3. Another resistor called R2 is connected between the negative power supply and the base of the transistor.
4. The collector of the transistor is connected to the positive power supply.
5. The emitter of the transistor is connected to the ground.

When the LDR is in the dark, its resistance is high. This means that there is very little current flowing through the transistor. As a result, the transistor is turned off and the LED is not lit. When the LDR is exposed to light, its resistance decreases. This means that more current flows through the transistor. As a result, the transistor turns on and the LED lights up.

The sensitivity of the sensor can be adjusted by changing the value of R2. The higher the value of R2, the less light is required to turn on the LED. This means that the sensor will be more sensitive to light.

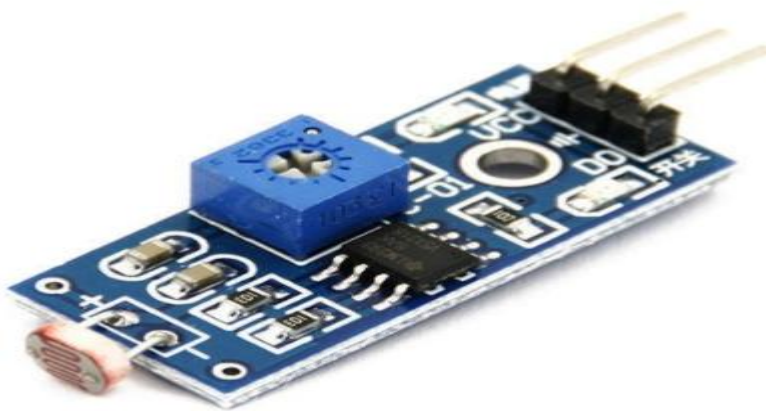

Figure 2.5 An LDR R2 Light Sensor

A photovoltaic (PV) module, often referred to as a solar panel, is a device designed to capture sunlight and convert it into electricity or heat. These panels are made up of multiple photovoltaic cells arranged in a grid-like pattern. They are known for their durability and slow wear-and-tear.

BENEFITS OF SOLAR PANELS

Installing solar panels in homes helps reduce harmful greenhouse gas emissions, which in turn helps combat global warming. Solar panels are environmentally friendly, as they do not cause pollution and reduce our reliance on finite fossil fuels and traditional energy sources.

TYPES OF SOLAR PANELS

There are three main types of solar panels:

1. **Monocrystalline Solar Panels:** These panels have been in use for over 40 years and are known for their durability. They have small solar cells and are suitable for limited spaces. They typically have a black or dark appearance with white diamond shapes on the surface and offer an efficiency of 18% and above.
2. **Polycrystalline Solar Panels:** These panels are also made of silicon and are known for their lower cost. They are blue in color and have a lower efficiency compared to monocrystalline panels.

3. Thin Film Solar Panels: These panels are made from various materials, including silicon, and are less common. They are lightweight and flexible but have lower efficiency and are more suitable for large-scale installations.

Each type of solar panel has its own advantages and disadvantages, and the choice depends on factors like space availability, budget, and efficiency requirements.



Figure 2.6 - Monocrystalline Solar Panel

2.5.6.1.2 POLYCRYSTALLINE SOLAR PANELS

Although polycrystalline panels are somewhat similar to monocrystalline, polycrystalline solar panels are a newer technology in renewable energy production and their efficiency may vary somewhat between manufacturers. Although the silicon used to create these panels are easier to make than monocrystalline technology, they typically feature similar or slightly less efficiency rates at an average of 15-16% plus.

The efficiency of these panels can vary based on the manufacturer, however, as some companies such as Trina Solar have recently boasted panels offering up to 21% efficiency.



Figure 2.7- Polycrystalline Solar Panel

2.5.6.1.3 THIN FILM SOLAR PANELS

Among the monocrystalline and polycrystalline panels, thin film panels are an outsider, constructed in a completely different way than the former two. As they are

the most recently-innovated variety, they are the least-developed of the three types.



Figure 2.8- Thin Film Solar Panel

In the IoT-based solar power monitoring system, the solar panel is a critical component that generates electrical power from sunlight. The working of the solar panel can be explained in the following steps:

Absorption of Sunlight: The solar panel is made up of photovoltaic (PV) cells, which absorb sunlight and convert it into electrical energy. When sunlight hits the PV cells, it excites electrons, creating a flow of electrical current.

Conversion of DC to AC: The electricity produced by the PV cells is in the form of direct current (DC), but household appliances use alternating current (AC). To make it compatible, we use an inverter, which connects to both the solar panel and the electrical grid, converting DC to AC. In an IoT-based solar power monitoring system, we keep track of the power generated by the solar panel in real-time. We do this using sensors for current and voltage, which continuously measure the

electrical power output. Additionally, we monitor the temperature of the solar panel using a temperature sensor. This sensor tells us the panel's temperature, which can impact how well it works. We also measure the intensity of light hitting the solar panel using a light intensity sensor. This helps us understand how much sunlight the panel is getting, which affects its electricity production.

Data Visualization: The data on the electrical power generated by the solar panel, its temperature, and light intensity are transmitted wirelessly to data visualization interfaces such as an LCD display, a website Thingspeak.com, and a computer screen. This allows users to monitor the performance of the solar panel in real-time. By continuously monitoring the performance of the solar panel using the IoT-based solar power monitoring system, it is possible to optimize its efficiency and reliability. The real-time data on the electrical power generated, temperature, and light intensity can be used to identify issues and address them promptly, ensuring that the solar panel operates at its maximum potential.

2.5.7 VOLTAGE SENSOR LM358

The LM358 is a dual operational amplifier (op-amp) integrated circuit (IC). It is a popular choice for voltage sensing applications because it is low power, inexpensive, and easy to use. The LM358 can be used to measure both AC and DC voltages. To measure an AC voltage, the LM358 is used in a non-inverting amplifier configuration. The non-inverting input of the op-amp is connected to the AC voltage source, and the output of the op-amp is connected to a voltmeter. The voltmeter will read the peak-to-peak voltage of the AC signal.

To measure a DC voltage, the LM358 is used in a non-inverting amplifier configuration with a DC bias voltage. The DC bias voltage is used to offset the output of the op-amp, so that the voltmeter will read the DC voltage of the signal.

Also the LM358 is a popular and widely used dual operational amplifier (op-amp) integrated circuit (IC) in electronics. While it is not specifically a voltage sensor, it can be used as part of a voltage sensing circuit due to its operational amplifier functionality.

An operational amplifier is a versatile electronic component that can amplify the difference in voltage between its two input terminals. It has a high gain and is commonly used in various analog signal processing applications, including voltage sensing and signal conditioning.

In the context of voltage sensing, the LM358 can be used as part of a voltage divider circuit or a comparator to measure or detect voltage levels. Here's how it can be utilized in these applications:

1. Voltage Divider Circuit:

The LM358 can be configured as a voltage divider circuit with a fixed resistor and a variable resistor (potentiometer). The variable resistor can be used to sense an external voltage, and the output of the LM358 will vary depending on the voltage level being sensed. This setup can be useful for applications like analog-to-digital conversion or for interfacing with microcontrollers or other electronic devices.

2. Voltage Comparator:

The LM358 can also be used as a voltage comparator. In this configuration, the voltage at one input is compared to a reference voltage at the other input. The output of the LM358 will change its state depending on whether the input voltage is higher or lower than the reference voltage. This setup is commonly used in various voltage threshold detection applications.

It's important to note that while the LM358 can perform voltage sensing tasks, it is primarily an op-amp with limitations and specifications. For precise and accurate voltage sensing applications, specialized voltage sensor ICs may be more suitable. Additionally, the design and implementation of the voltage sensing circuit using the LM358 will depend on the specific requirements of the application.

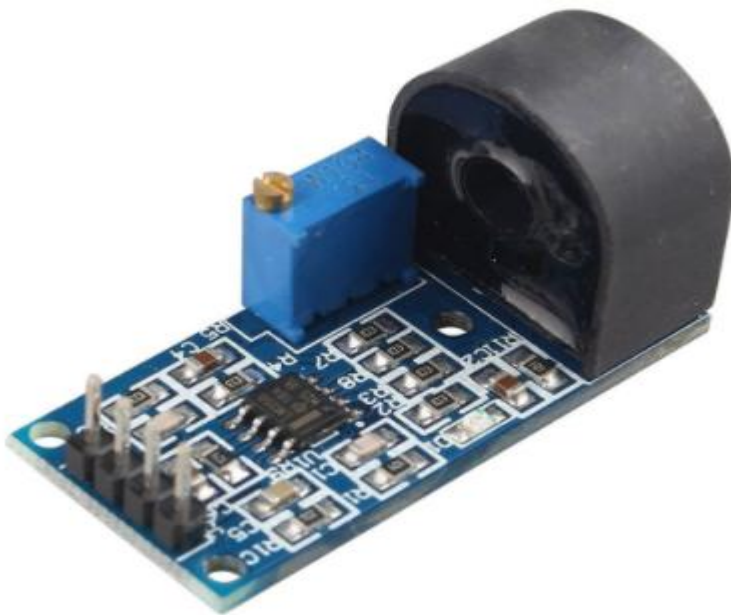

Figure 2.9 LMC358

2.5.8 PRINTED CIRCUIT BOARD

A printed circuit board, or PCB for short, is a crucial component in electronics. It serves two main purposes: providing mechanical support and creating electrical connections for electronic parts. It does this by using conductive pathways made of copper that are etched onto layers of non-conductive material. Imagine it like a sandwich made of different layers. The conductive layers have patterns etched into them, similar to wires on a flat surface. These patterns connect and carry electrical signals between electronic components. These conductive layers are sandwiched between non-conductive layers, creating a sturdy and functional circuit board. PCBs are fundamental in making electronic devices work efficiently.

PCBs can be classified into a number of different types, depending on the materials used and the manufacturing process. Some of the most common types of PCBs include:

1. Rigid PCBs: Rigid PCBs are made from a non-conductive substrate material such as FR-4 (fiberglass epoxy resin). Rigid PCBs are the most common type of PCB, and they are used in a wide variety of applications.
2. Flexible PCBs: Flexible PCBs are made from a flexible substrate material such as polyimide. Flexible PCBs can be bent and flexed, making them ideal for applications where space is limited or where the PCB needs to be able to move.
3. Multilayer PCBs: Multilayer PCBs have multiple layers of conductive traces and insulating material. Multilayer PCBs are used in complex applications where a large number of components need to be connected.

PCBs are essential components in modern electronics. They provide a reliable and efficient way to connect electronic components, and they enable the creation of smaller, lighter, and more complex electronic devices.

(www.wikipedia.org/wiki/Printed_circuit_board)

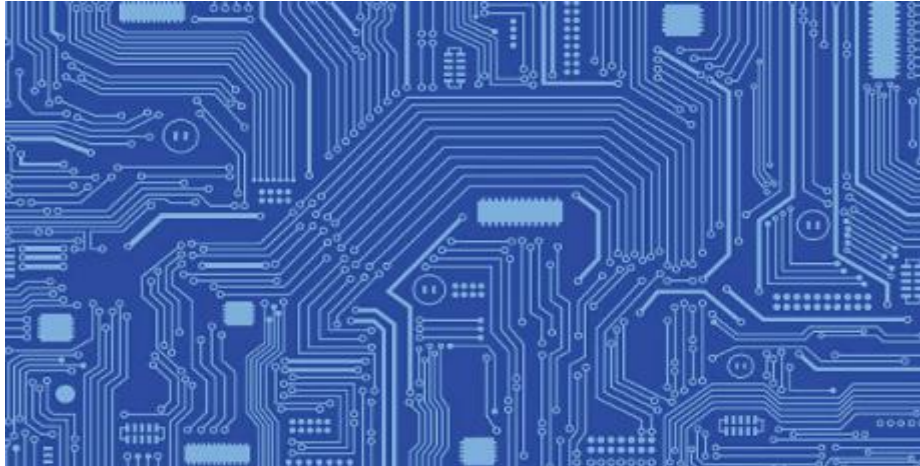

Figure 2.10 A typical PCB

2.6 DESIGNING A REMOTE MONITORING SOLAR POWER SYSTEM

In designing a remote monitoring solar power system using IoT, it involves integrating smart devices and communication technologies to monitor and manage solar energy generation and consumption. Below are the general components/steps to design such a system:

1. **Solar Panels and Energy Storage:** Install solar panels to capture sunlight and convert it into electrical energy. Include energy storage solutions like batteries to store excess energy generated during peak sunlight hours for later use, especially during non-sunny periods or at night.

2. **IoT Sensors and Devices:**

For a solar power system, one might need sensors to measure the following:

Ambient temperature: This will help keep track of the performance of the solar panels in different weather conditions.

Solar irradiance: This will help track the amount of sunlight the solar panels are receiving.

Output voltage: This helps track the amount of electricity the solar panels are generating.

Current: This helps to keep track of the amount of current the solar panels are generating.

Power: This also will help to keep track of the total amount of power the solar panels are generating.

3. **Communication Gateway:** Set up a communication gateway that connects the IoT devices to the internet. This gateway acts as a bridge between the devices and the remote monitoring platform. The gateway should support the chosen communication protocols, such as MQTT, HTTP, or CoAP, to transmit data securely and efficiently.

4. **Data Transmission and Cloud Storage:** Transmit the collected sensor data securely over the internet to a cloud-based data storage system. Cloud services like AWS IoT Core, Microsoft Azure IoT Hub, or Google Cloud IoT Core are popular choices for this purpose. Ensure data encryption and proper access controls are in place to protect sensitive information.

5. **Remote Monitoring Platform:** Develop a web-based or mobile application as a remote monitoring platform. The platform should have a user-friendly interface that allows users to access real-time and historical data on solar energy generation, battery

status, and energy consumption. Provide alerts and notifications for critical events like low battery levels or system malfunctions.

6. Data Analysis and Insights: Implement data analysis tools and algorithms to process the collected data and generate insights.

Analyze solar energy generation patterns, optimize energy consumption, and identify potential efficiency improvements.

7. Automation and Control: Enable remote control of certain devices and settings to optimize energy consumption.

Implement automation routines to adjust energy usage based on available solar power and battery levels.

8. Energy Management and Load Balancing: Implement load balancing algorithms to manage energy consumption based on available solar energy and battery capacity. Optimize the utilization of stored energy to avoid waste and ensure a steady power supply.

9. Fault Detection and Maintenance

2.7 BLOCK DIAGRAM SHOWING DESIGN METHODOLOGY

The design of the system is presented in the following sections according to the block diagram representation and the analysis is based on the solar system's power to store, analyze data consisting of ambient temperature using Internet of Things (IoTs)

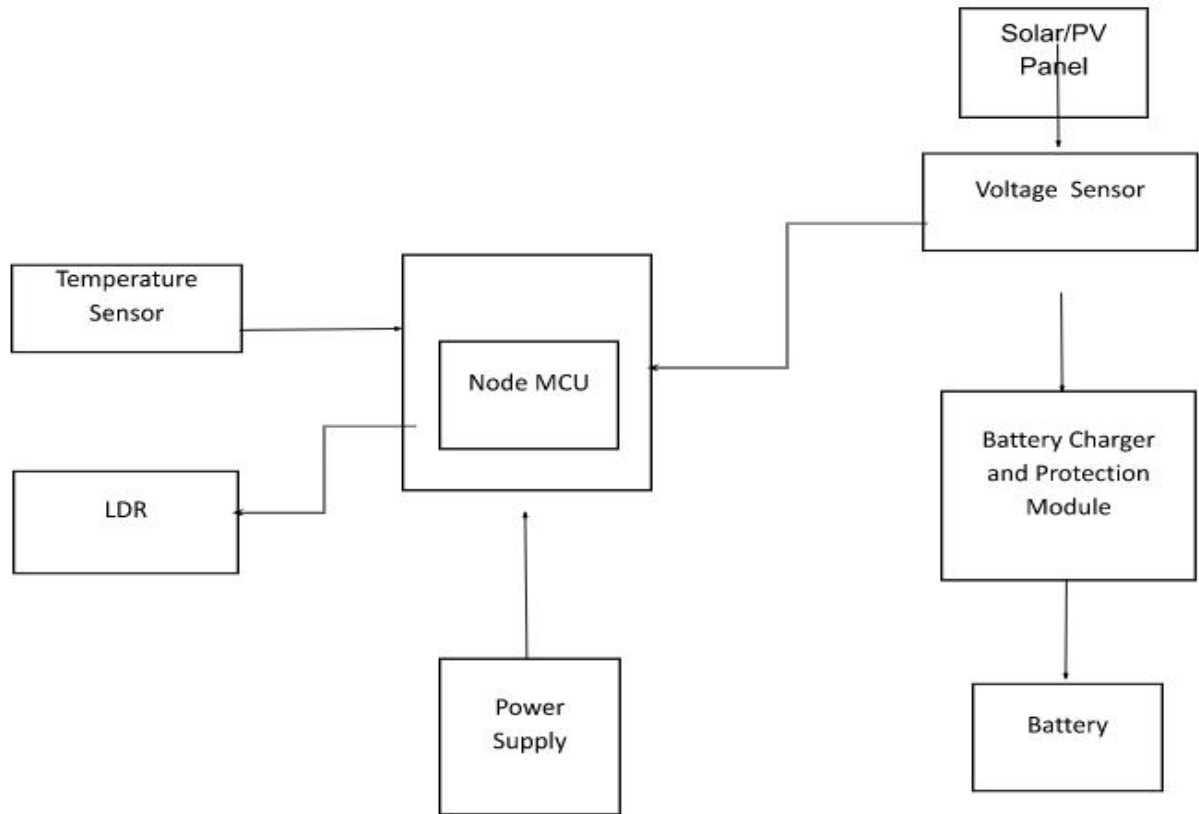

Figure 2.11 Block Diagram Showing Design Methodology

CHAPTER THREE

DESIGN METHODOLOGY

The design process chosen for the project's implementation focuses on choosing the sensor, microcontroller, wireless communication module, developing the data visualization interface, and generating alerts. The following components make up the circuit:

1. Battery
2. Buck Converter (Voltage Regulator)
3. LM358 Voltage Sensor
4. LDR Sensor
5. ESP32 Node MCU
6. DHT 11 Sensor
7. LCD Display

3.1 DESIGN OF VOLTAGE SENSING CIRCUIT

The figure 3.2 below shows the voltage sensing circuit of the

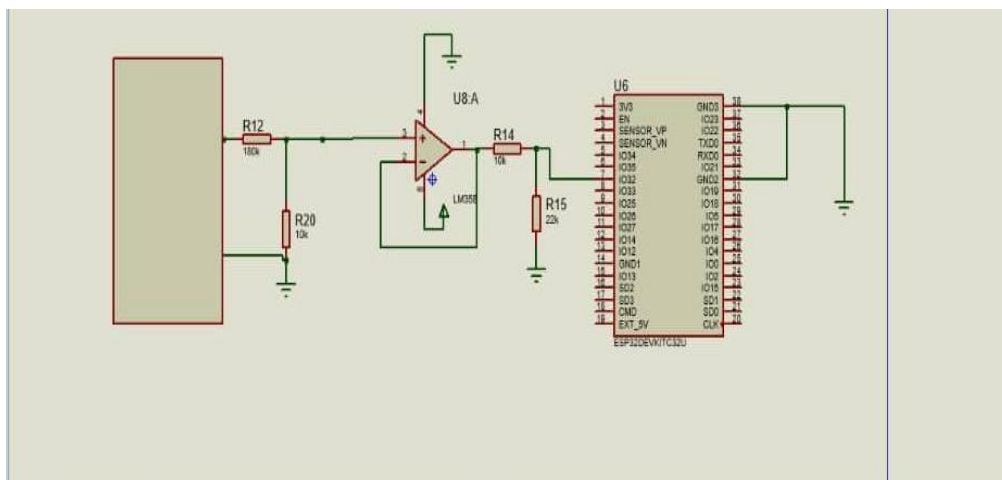

Figure 3.1 Voltage Sensor Circuit.

Input to the Voltage Sensor

Designing for 50volts maximum: Choosing R_1 to be $180k\Omega$

($180k\Omega$ is large enough to draw minimum current from the PV cell)

$$\text{From voltage divider rule: } V_{out} = \frac{R_2}{R_1 + R_2} \times V_{pv} \text{ ----- (1)}$$

Where, V_{out} = Output Voltage = 5volts

V_{pv} = Voltage of the PV module = 50volts

$$5v = \frac{R_2}{180k\Omega + R_2} \times 50v \text{ -----(2)}$$

Calculating for R_2 , we have: $R_2 = 20k\Omega$

A 5volt output is suitable for most 5v controllers but the ESP32 needs 3.3volts at the ADC pin. Hence another voltage divider

Assuming $R_6 = 10k\Omega$ (Based on choice)

$$3.3v = \frac{R_7}{10k\Omega + R_7} \times 5v \text{ -----(3)}$$

Calculating for R_7 , we have: $R_7 = 17.837k\Omega$

Resistor found on the market was $22k\Omega$.

$$V_{mcu} = \frac{22k\Omega}{10k\Omega + 22k\Omega} \times 5v \text{ -----(4)}$$

$V_{mcu} = 3.4375$ volts (This is good enough)

To Find the Gain

$$\text{Attenuation factor of first voltage divider} = \frac{R_5}{R_4 + R_5} \text{-----(5)}$$

$$= \frac{20k\Omega}{180k\Omega + 20k\Omega} = 0.1$$

$$\text{Attenuation factor of second stage} = \frac{R_7}{R_6 + R_7} \text{-----(6)}$$

$$= \frac{22k\Omega}{10k\Omega + 22k\Omega} = 0.6875$$

$$\text{Total Attenuation} = 0.1 \times 0.6875 = 0.06875 \text{-----(7)}$$

$$\text{Gain to multiply within the ESP32} = \frac{1}{\text{Total attenuation}} \text{-----(8)}$$

$$\frac{1}{0.06875} = 14.55$$

3.2 DESIGN OF THE BUCK-CONVERTER OR VOLTAGE REGULATOR SUB-CIRCUIT

The Buck Converter being a Dc-Dc converter converts the 12 volt output from the battery to 5 volts. Figure 3.3 below shows the buck converter circuit.

3.4 DESIGN OF THE DHT11 SUB CIRCUIT

The voltage rating of a DHT11 sensor is between 3-5 volts

. Figure 3.5 shows the DHT11 sub-circuit.

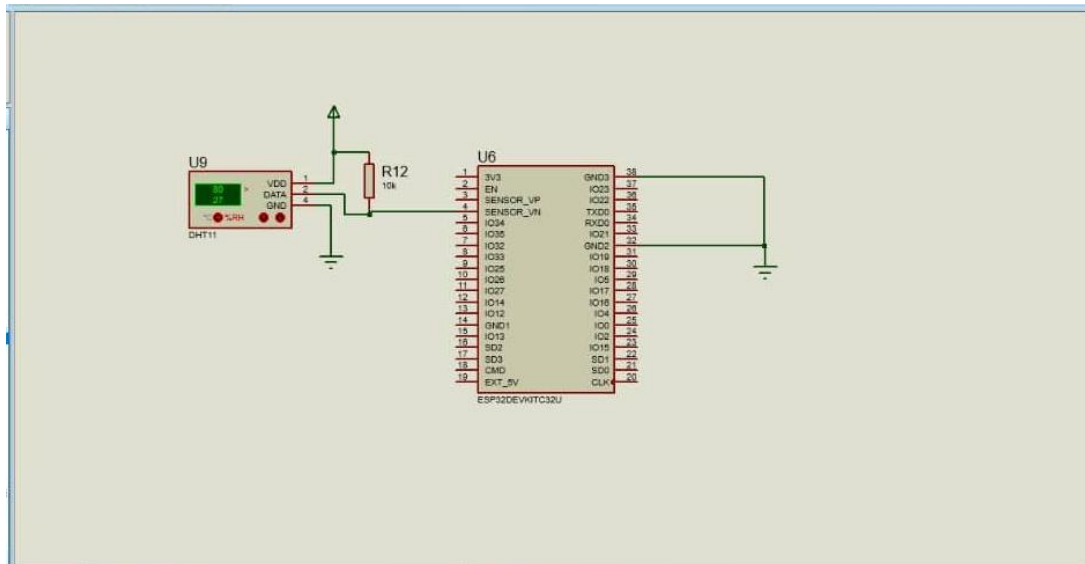

Figure 3.4 DHT11 Sub-Circuit

3.5 DESIGN OF THE LCD SUB-CIRCUIT

The absolute maximum rating of the LCD Sub-circuit is 6.5 volts.

Figure 3.6 shows the LCD sub-circuit.

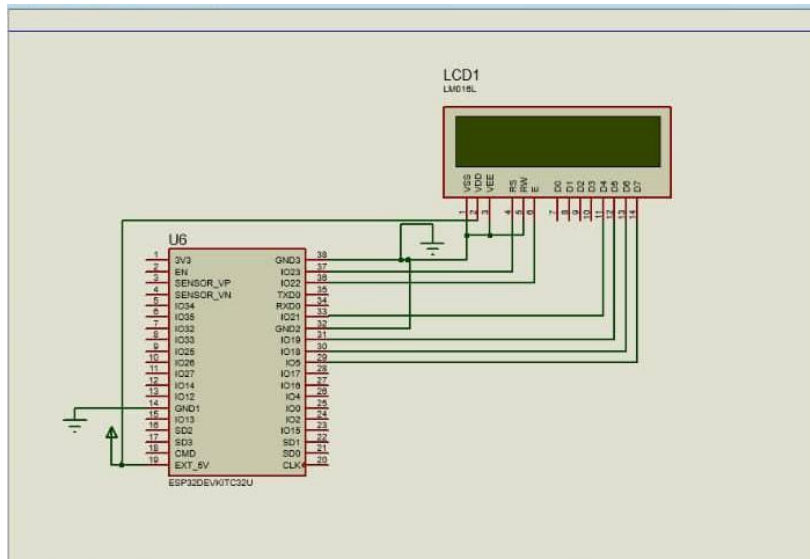

Figure 3.5 LCD Sub-Circuit

3.6 SOLAR PANEL SELECTION

For the actualization of this project four 320watt monocrystalline solar panels were used.

3.6.1 SOLAR PANEL PARAMETERS

The table below shows the monocrystalline solar panel parameters.

ITEM	SPECIFICATION	DESCRIPTION AND REMARK
Model	AT-GLASS-MONOSOL-24-320WV01	320W 24V Glass Monocrystalline Solar Panel
Maximum Power Rating	Pmax 320 Watt	
Solar Panel Dimensions	L-1650mm x W-990mm x H- 35mm	
Tolerance on Power Output	+/- 3.0 %	

Current at max power	Imax 9.33 Amps	
Voltage at max power	Vmax 34.32 Volts	
Short circuit current	Isc 9.94 Amps	
Open Circuit voltage	Voc 40.26 Volts	
No of cells	60	
Cell Efficiency	21.80%	
Temperature coefficient- short circuit current	1.2mA/°C	
Weight	18.0kg	

Table 1: Monocrystalline Solar Panel Parameters

3.7 DESIGN OF THE WEB SOFTWARE

In this design, the ESP32 microcontroller is selected because of the built-in Wi-fi and Node-MCU capabilities; the Node-MCU transmits data to the Thingspeak.com channel. The ESP32 microcontroller core is typically clocked at 160Mhz and the ESP32 requires a 5V source for its operation.

An Arduino-IDE is used to upload the programming instructions to the ESP32 microcontroller via the internet which controls the board. This is because there is an add-on for the Arduino-IDE which allows the program of the ESP32 using the Arduino-IDE and its programming language (A simplified version of C++ is used in Arduino-IDE).

The figure below shows the software design flow chart

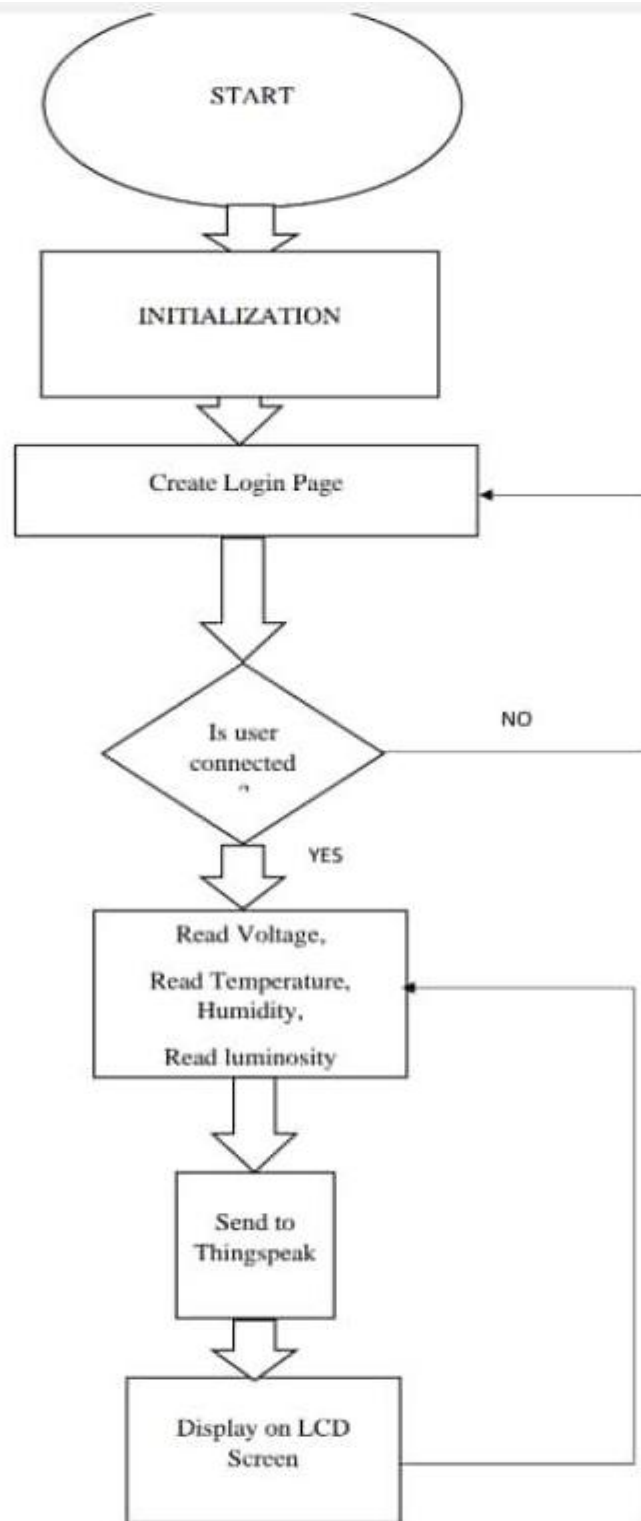

Figure 3.6 Flow Chart Illustrating the Web Design Software

3.8. CIRCUIT DIAGRAM

IOT BASED REMOTE MONITORING OF PV SYSTEM SCHEMATIC CIRCUIT

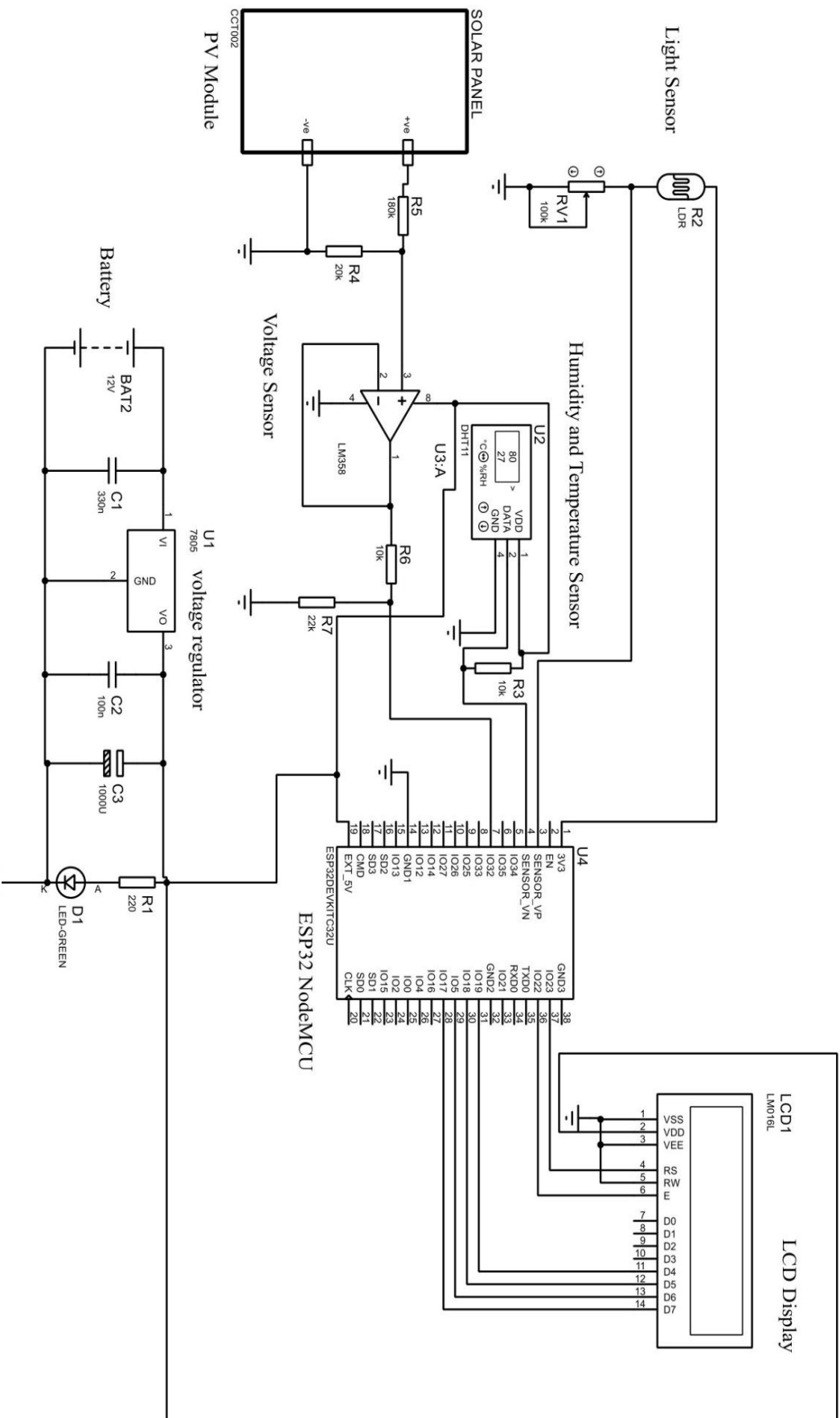

Figure 3.7 Circuit Diagram of A Remote PV Monitoring System

IOT BASED REMOTE MONITORING OF PV SYSTEM SCHEMATIC CIRCUIT

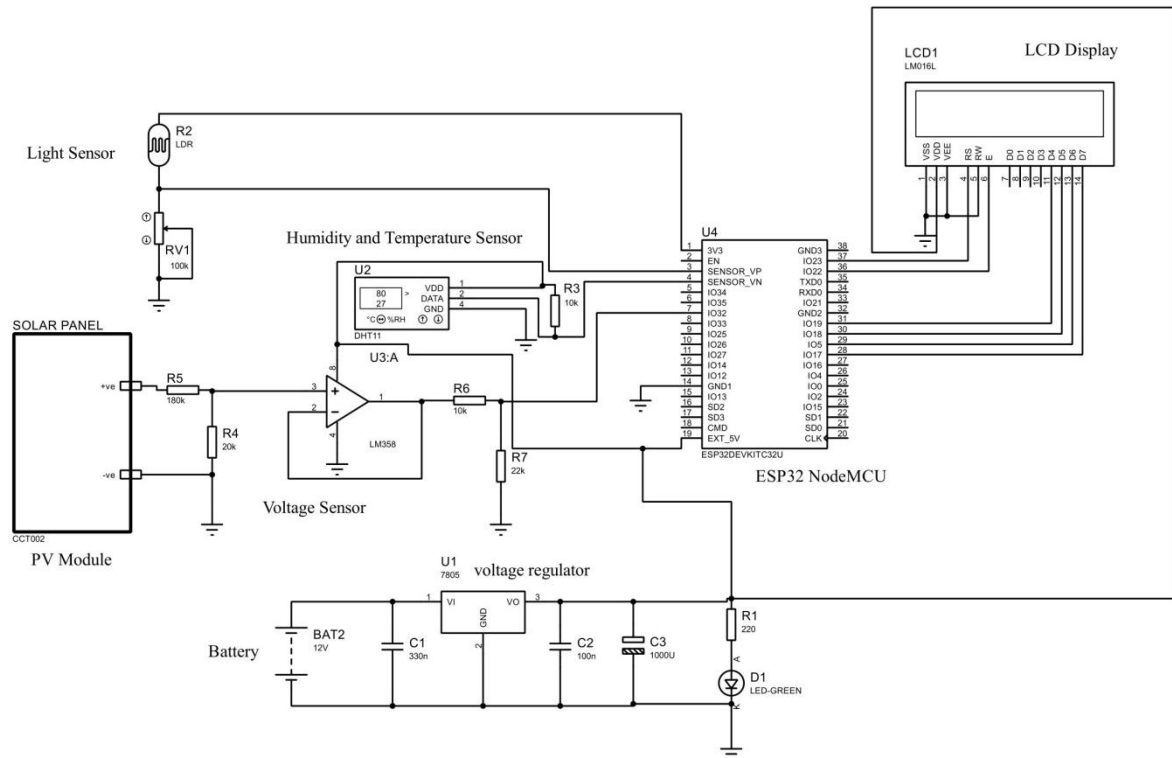

Figure 3.7 Circuit Diagram of A Remote PV Monitoring System

3.9 WORKING PRINCIPLE OF THE CIRCUIT

This IoT device operates by efficiently managing power sources and sensors to monitor and optimize the performance of a photovoltaic (PV) panel system. It is powered by a 12V lithium-ion battery, which is converted to a stable 5V using a voltage regulator (buck converter). This 5V power supply drives the entire system, ensuring reliable and consistent operation. The system collects data from various sensors, including the solar panel's voltage, temperature, humidity, and luminance. These sensors are carefully powered and integrated into the system to provide accurate and real-time information. For example, the voltage from the solar panel is reduced to

a safe 5V level through a voltage divider and an operational amplifier before being processed by the ESP32 microcontroller. This voltage data is then displayed on an LCD screen and transmitted to the Thingspeak cloud platform for further analysis and monitoring.

The DHT11 sensor, which measures temperature and humidity, and the Light Dependent Resistor (LDR) for luminance, are also meticulously powered and calibrated to provide accurate readings. These sensors contribute valuable environmental data, which is essential for understanding the conditions affecting the PV panel's performance. Moreover, the IoT application includes a sun tracking feature that utilizes LDR sensors to determine the position of the sun. This information, combined with the environmental data, helps calculate the solar irradiation, allowing for optimal adjustment of the PV panel's orientation to maximize energy extraction. The collected data is sent to a cloud-based web server via an Ethernet shield connected to the NodeMCU microcontroller. This data can be accessed in real-time through a user-friendly dashboard on the Thingspeak platform, enabling users to monitor PV panel performance and environmental conditions remotely.

Additionally, the IoT application offers the convenience of notifications via SMS or email when predefined threshold values are reached, ensuring that users can take prompt action if any issues arise. Overall, this IoT-based monitoring system provides valuable insights and control over PV panel performance and environmental factors, facilitating the efficient utilization of solar energy resources.

CHAPTER FOUR

CONSTRUCTION, TESTING AND RESULT

4.1. CONSTRUCTION.

This project was designed and mounted on printed circuit board. After testing, each component was attached one at a time. Once the circuit had operated satisfactorily, the components were permanently soldered on a printed circuit board.

The following equipment and tools were used during the construction process;

- A. Long nose pliers
- B. Printed Circuit Board (P.C.B)
- C. Wire cutter
- D. Lead
- E. Digital multimeter
- F. Soldering iron

Prior to moving the components to the P.C.B for permanent soldering, bread boarding was performed in order to verify that the design will function when tested and, if not, what corrections and modifications must be made. The circuit components were moved to the printed circuit board for permanent soldering once the bread boarding and test were completed with any necessary adjustments made. A continuity test was performed after all of the soldering was finished to look for any potential shorts.

4.1.1 SOLDERING

The soldering was done on the printed circuit board using a soldering iron (60 watts). The components were mounted on printed circuit board the according to the circuit diagram.

4.1.2 COUPLING

After the electronic circuit was completed, it was fixed to the casing using hot glue. Every component involved in the circuit assembling was in this casing except the L.C.D screen, the DHT11 and the L.D.R sensor which were mounted on the casing

4.1.3 CASING

A plastic casing which offers good insulating properties was used in casing the printed circuit board. The input of the solar panel voltage supplying the LM35 is external to this box and is connected using terminal block.

Figure 4.1 below shows the casing used in the construction of the IOT device.

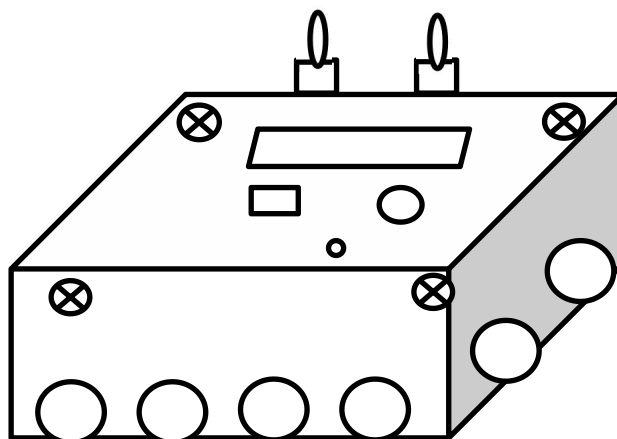

Figure 4.1. 6 X 6 Inch Casing

4.2. INSTALLATION

Figure 4.2 shows the installation of the solar panels and the IOT device.



Figure 4.2 Installation of the device and solar panel

4.3 TESTING AND RESULTS

The project components were tested independently as stated before and also as a unit for various forms of parameters.

During testing with the solar panel, the following were derived over the course of a week.

Table 4.1: Readings of Voltage, Temperature, Time, Date, Humidity and Luminance.

S/N	Date	Humidity (g/m ³)	Voltage (V)	Time (hrs)	Temperature (°C)	Luminance (cd/m ²)
1.	17-08-2023	81	34.12	6:48 pm	31	2412
2.		83	0	7:56 pm	29	0
3.	18-08-2023	83	35.16	7:46 am	31	4031
4.		83	35.28	9:12 am	31	4100
5.		82	35.71	10:40 am	31	4114
6.		82	35.98	12:00 pm	31	4201
7.		82	35.82	2:15 pm	31	4131
8.		85	35.12	4:15 pm	31	4037
9.		85	35.44	6:40 pm	31	4110.3
10.	19-08-2023	83	34.9	8:00 am	30	3514
11.		83	35.1	9:00 am	30	4034
12.		79	35.6	12:10 pm	32	4116
13.		79	35.78	1:00 pm	32	4121
14.		80	35.3	3:08 pm	32	4101
15.		80	35.17	5:15 pm	32	4096
16.		81	0	8:30 pm	30	0
17.	20-08-2023	79	35.04	9:05 am	32	4029
18.		79	35.08	11:00 am	33	4093
19.		80	34.96	12:15 pm	32	4093

20.		79	35.12	5:35 pm	33	4095
21.		87	0	8:30 pm	27	0
22.	6-09-2023	87	34	8:00 am	32	3665
23.		86	34.53	9:00 am	32	3900
24.		89	34.82	11:00 am	32	4014
25.		87	35.28	1:30 am	31	4078
26.		87	26.56	5:30 pm	32	3777
27.	7-09-2023	85	0	6:30 am	30	0
28.		85	34.9	9:00 am	32	4005
29.		84	35.14	10:00 am	32	4075
30.		84	35	12:00 pm	32	4051
31.		84	35.09	1:00 pm	32	4061
32.		84	35.12	2:00 pm	32	4096
33.		84	34.99	4:00 pm	32	4016
34.		82	29.78	6:00 pm	31	3512.3
35.		85	0	7:00 pm	30	649.1
36.	8-09-2023	80	35.1	8:30 am	32	3839
37.		80	35.12	10:00 am	32	3709
38.		80	34.98	10:30 am	32	3742
39.		83	34.6	12:30 pm	31	3301
40.		83	28.13	5:20 pm	30	2295
41.	9-09-2023	80	35.26	12:30 pm	32	3985
42.		80	35.21	1:45 pm	32	4015
43.		80	35.18	2:30 pm	32	3785

The figure below shows a graphical representation of voltage against humidity.

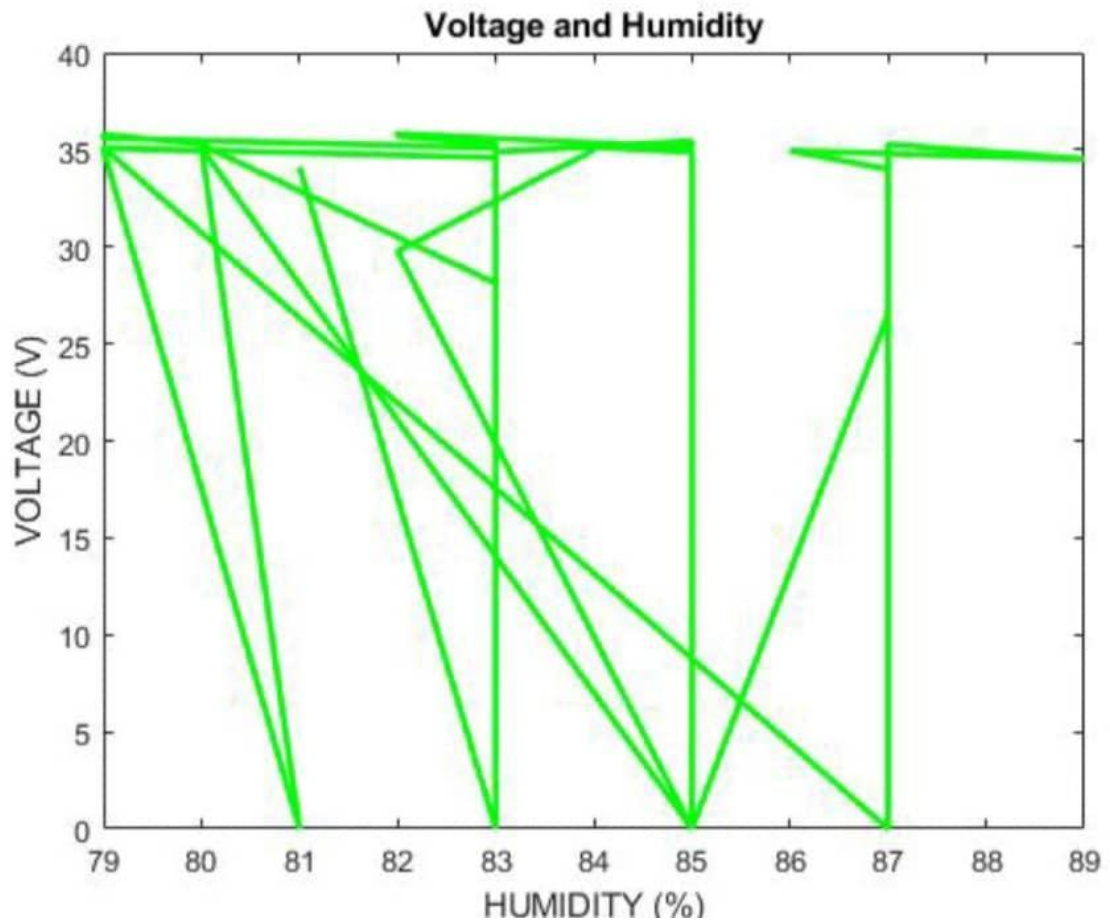

Figure 4.3: Graphical Representation of voltage verses humidity

The figure below shows a graphical representation of voltage against time.

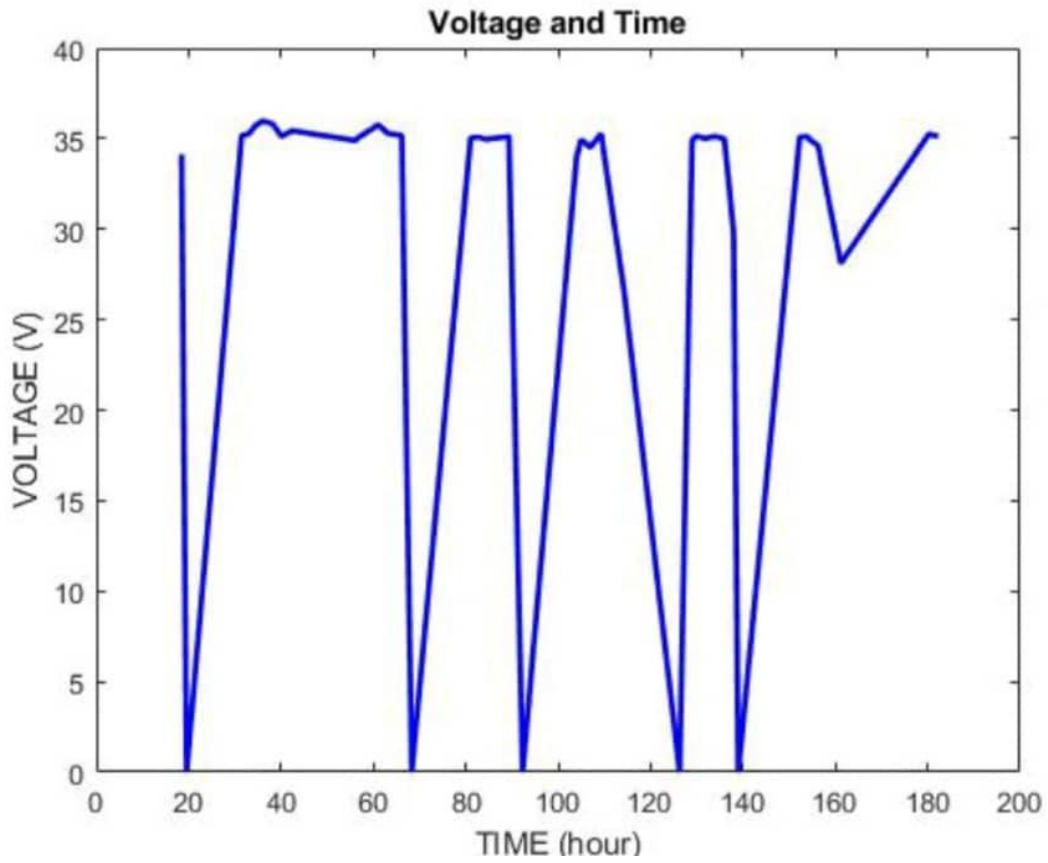

Figure 4.4: Graphical Representation of Voltage against Time

The figure below shows a graphical representation of temperature against time.

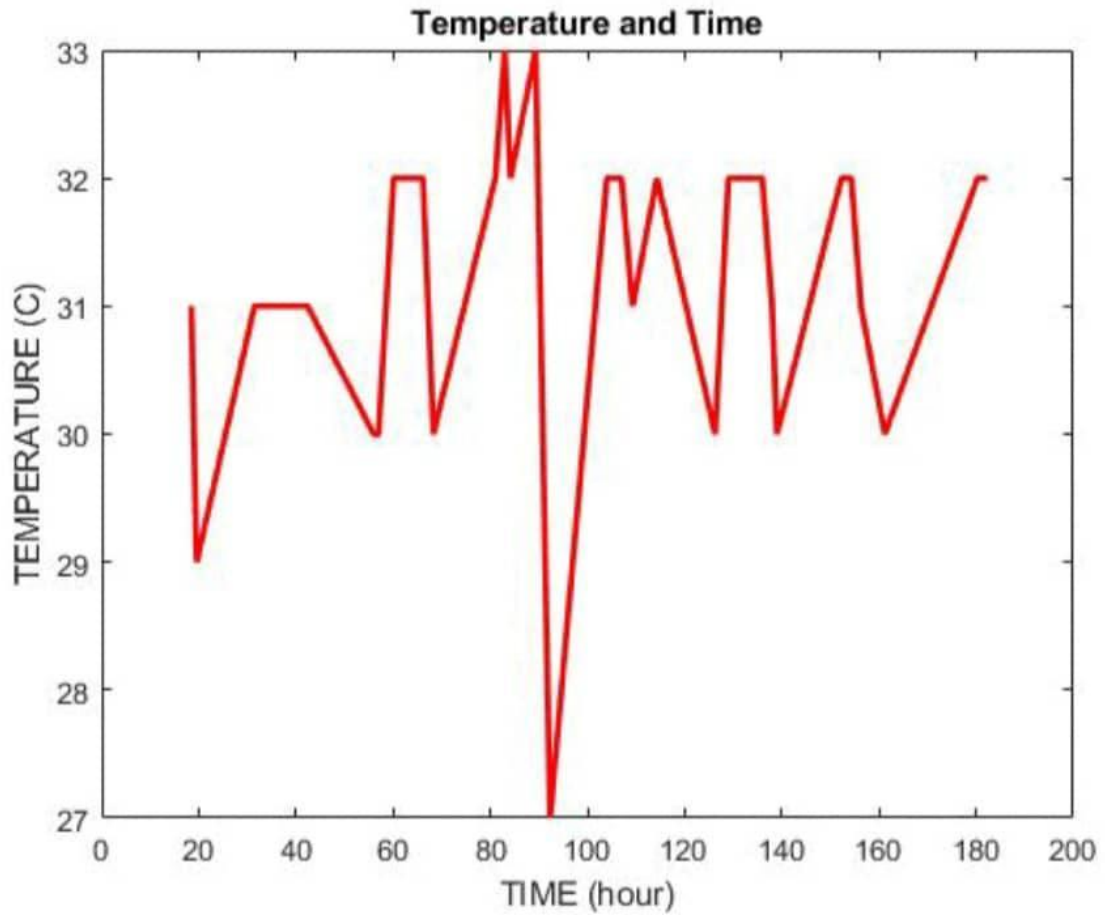

Figure 4.5: Graphical Representation of temperature verses time

The figure below shows a 3D graphical representation of time, voltage and luminosity.

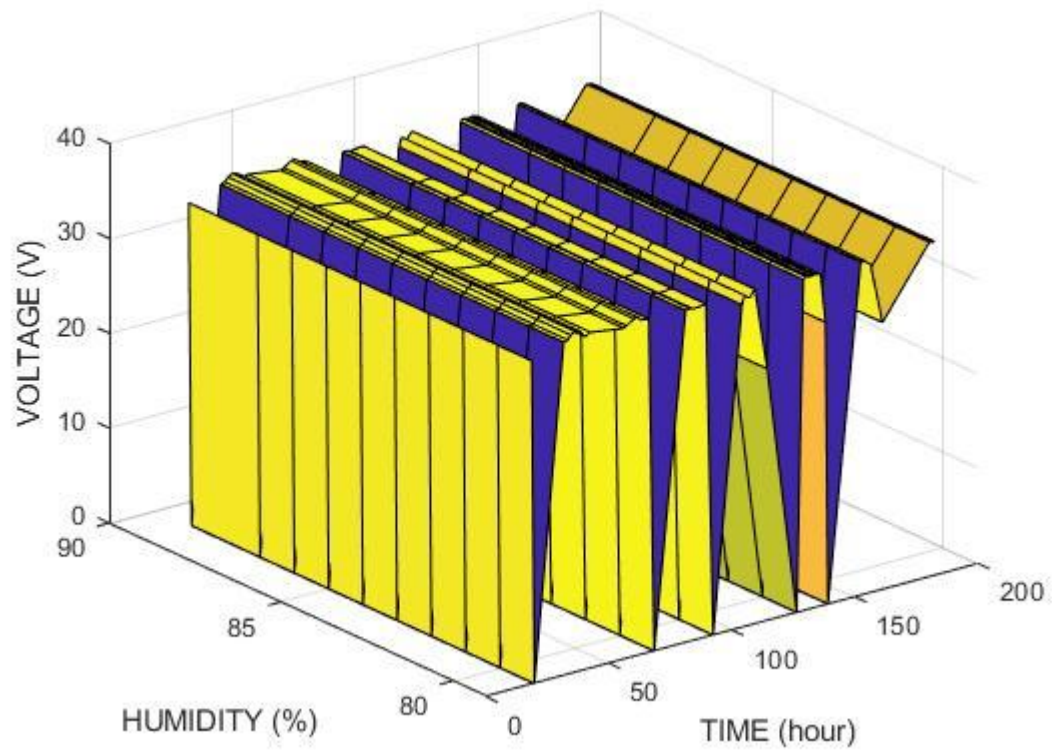

Figure 4.6: Graphical Representation of time, voltage and luminance

The figure below shows a 3D graphical representation of time, voltage and humidity.

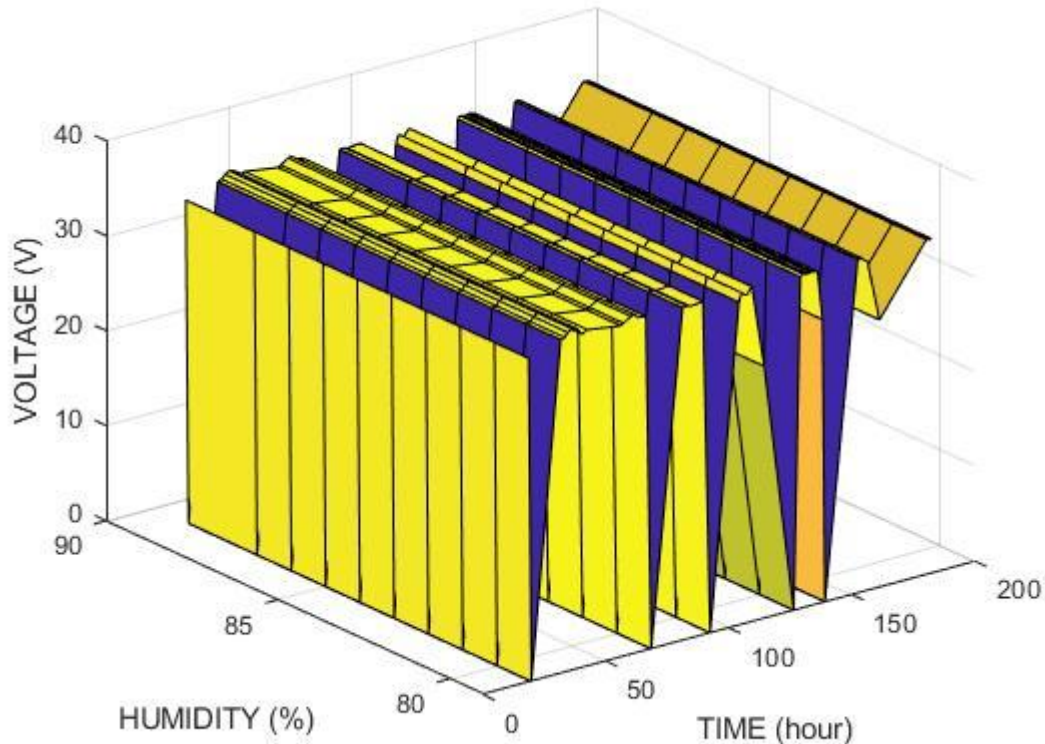

Figure 4.7: Graphical Representation of Time, Voltage and Humidity

4.4 DISCUSSION AND FINDINGS

The humidity has an inverse relationship with the output voltage of the P.V cells; meaning the greater the humidity, the smaller the output voltage. The p.v voltage output is reduced when the relative humidity is increased, high humidity reduces the output voltage of the solar panel by slowing down the efficiency of the solar panel and this is because at high humidity, tiny water droplets or water vapour on the surface of the solar panel causes reflection or refraction and thereby reducing the amount of sunlight hitting cells.

The time of the day is a major determining factor of the output p.v voltage. In the early hours of the day (5am -6am) and cool evening of the day (6:30pm and later), the output voltage is significantly low; this is because at this, time the intensity of the sun is low and at midnight the effect of humidity is higher. The output voltage is at maximum between 11am - 2pm because of the sun.

The time and temperature are two independent variables. The relationship is complex to some extent because there are many factors to be considered, because these factors include daily and seasonal patterns as well as longer term trend.

The amount of sunlight energy received per unit area varies with time throughout the day and also across different seasons. The generated voltage on the solar panel depends on the luminance level caused by the sun's position and environmental conditions. The relationship between voltage and time depends on the intensity of sun, as solar irradiance increases during the day, the voltage output of the solar panel also increases.

Relative humidity is usually very high at midnight and early morning, which in turn reduces the output voltage of the solar panel. Humidity can also be very high under rainy condition which will also reduce the output voltage of the solar panel.

With each panel rated 24V (having 4 in total), with an IoT devices not exceeding 50V, if it is connected in series, the PV volts would not exceed 50V when in reality it is 96V. So, connecting the panel in parallel is done to get accuracy in the reading.

Temperature obtained from the IoT device varied from minimum of 27 to 33 degree in Celsius which was same as the temperature obtained from other systems (weather stations) within the period the IoT device readings were taken.

The humidity of the IoT device varied from 79 to 83 (g/m^3) which is the average range of humidity within the period the reading was taken.

The voltages of the p.v ranged from minimum of 28.12V to maximum of 35.96V which is actually the expected output for the configuration used in connecting our solar panels to give output voltage of 24V.

The luminance has a minimum range of 2295 lux and maximum of 4201 lux, there are instances where 0 lux was obtained which was as a result of the time of the day (i.e late hours when it is dark) the luminosity reading from the IoT device is taken. Usually, shadow tends to affect the reading of the luminosity. So, precautions were taken to avoid this effect.

4.5 BILL OF ENGINEERING MEASUREMENT AND EVALUATION.

TABLE 4.2: BILL OF ENGINEERING MEASUREMENT AND EVALUATION

The table 4.2 below shows the bill of engineering measurement and evaluation.

S/N	DESCRIPTION OF COMPONENTS	QUANTITY	UNIT COST (N)	TOTAL COST (N)
1	Panel	4	72000	288,000
2	NodeMCU IoT Controller PSP 32 NODEMCU	1	35000	35,000
3	Voltage Sensor Module LM358	1	5000	5,000
4	PCB board	1	2000	2,000
5	Etching power	1	5000	5,000
6	Temperature and humidity sensor DHT11	1	7000	7,000
7	Light sensor R2 LDR	1	8200	8,200
8	LCD display LCD1 LM01016L	1	5000	5,000
9	Terminal block connector	1	2500	2,500
10	Casing	1	5000	5,000
11	Lithium-ion battery 7.4v 8000mAh	1	8500	8,500
12	Voltage regulator U1 7805	1	500	500
13	Resistor and Capacitor	1	1000	1,000
	TOTAL			372,700

CHAPTER FIVE

CONCLUSIONS AND RECOMMENDATIONS

5.1 CONCLUSION

The IoT-based solar power monitoring system is an innovative project that provides real-time monitoring and analysis of various parameters of a solar panel. The system has several advantages, including efficient energy management, improved solar panel performance, and increased system reliability. The system's hardware components include the solar panel, voltage sensor, current sensor, ESP32 microcontroller, LCD display, and other components. The software modules of the system include the Thingspeak mobile web application and the computer program. The ESP32 microcontroller acts as a bridge between the hardware components and the software modules, processing and displaying the collected data. The ESP32 microcontroller processes and displays the collected data on the LCD display, the Thingspeak mobile web application, and the Arduino program. The system continuously monitors and updates the data, providing real-time analysis and monitoring of the solar panel's performance.

The IoT-based solar power monitoring system is a valuable tool for efficient energy management and real-time monitoring of solar panel performance. The system's ability to continuously measure and analyze various parameters of the solar panel can help improve its performance, reduce maintenance costs, and increase system reliability. It can also help users make informed decisions regarding their energy consumption and contribute towards sustainable development.

5.2 RECOMMENDATIONS

The IoT-based solar power monitoring system has several potential future applications, advancements, and further research studies such as;

1. Integration with smart home systems: The system can be integrated with smart home systems to provide real-time monitoring and control of energy consumption and solar panel performance.
2. Predictive maintenance: The system can be further developed to include predictive maintenance capabilities, using machine learning algorithms to predict when maintenance will be required based on performance data.
3. Remote monitoring: The system can be enhanced to enable remote monitoring of solar panels, allowing users to monitor their solar panel's performance from anywhere.
4. Energy trading: The system can be integrated with energy trading platforms, enabling users to sell excess energy generated by their solar panels.
5. Use in industrial and commercial settings: The system can be adapted for use in industrial and commercial settings, providing real time monitoring and analysis of renewable energy systems in larger settings.

Overall, the IoT-based solar power monitoring system has significant potential for future development and expansion, offering numerous benefits in terms of energy management, sustainability, and cost savings.

REFERENCES

1. Srinivasan K.G(2019). Solar Monitoring System by IoT.
2. Rumbayan, M., Pundoko, I., Ruindugan, D., Panjaitan, N.V. (2021). Development of Internet of Things Based Monitoring System for Application of Solar Energy Technology in Bunaken Island.
3. Guarav Khambalkar, Atharva W., Ritesh, J., Suraj Dongare, Vijay C. (2023). Solar Power Monitoring System using IoT System, IJCRT.
4. Stoichkov V., Bristow, N., Troughton, J., Kettle, J. (2018). Outdoor Performance of Monitoring of Perovskite Solar Cell Mini-Modules;Observance of Reversible Degradation and Variation with Climatic Performance. Sol, Energy, 170,549-556.
5. IoT Based Solar Energy Monitoring System;
<https://www.sciencedirect.com/science/article/pii/S09596526210052238>.
6. George, S., Rajase Karan, Anbazhagan, S., Senthikumar, K., Suresh, M., Sivakumar, V., “Solar Power Monitoring and Control System Using Internet of Things (2021).
7. Zamora, N., Aranda, J., Sanchez-Marquez, J., Manas, J.M. (2019). Internet of Things Applied to Photovoltaic Solar Energy Generation Systems.
8. Rumbayan M, Sompie, R. U. S, Ruindungan, G. S. D. and Panjaitan, V. N., (2021) Model of solar energy utilization in Bunaken Island Communities IOP Conf. Ser.: Earth Environ. Sci. 739 012082
9. Rumbayan M, Ruindungan D, Sompie, S and Sambul, A. (2019). The concept of the internet of things framework for remote monitoring of solar home system, Journal of Physics: Conference Series, Volume 1402, Issue 4, 1402 044006

10. Jamil, N. A. A., Jumaat, S., ASalimin, S., Abdullah M, N.,(2020) Performance Senhancement of solar powered floating photovoltaic system using arduino approach. Int. J. Power Electron. Drive Syst. 2020, 11, 651–657.
11. PCB and PCBA Prototypes and small series design in electronic subcircuits.
www.eurocircuits.com
12. Applications of PCB in modern electronic design and its uses the general engineering context www.wikipedia.org/wiki/Printed_circuit_board.

APPENDIX

```
#include <WiFi.h>
```

```
#include <WebServer.h>
```

```
#include <WiFiManager.h>
```

```
#include "DHT.h"
```

```
#include "Wire.h"
```

```
#include "Adafruit_LiquidCrystal.h"
```

```
#define CH1 39
```

```
#define VREF 50
```

```
#define RS 23
```

```
#define EN 22
```

```
#define D4 21
```

```
#define D5 19
```

```
#define D6 18
```

```
#define D7 5
```

```
Adafruit_LiquidCrystal lcd(RS, EN, D4, D5, D6, D7);
```

```
String apiKey = "YCPLJSSX05AN3L92";
```

```
const char* server = "api.thingspeak.com";
```

```
WiFiClient client;
```

DHT dht;

float Humidity, Temperature;

float volt_ch0 = 0.0;

float volt_ch1 = 0.0;

float ldr = 0;

void setup() {

Serial.begin(115200);

pinMode(17,OUTPUT);

digitalWrite(17,HIGH);

lcd.begin(20,4);

lcd.setCursor(4,0);

lcd.print("WELCOME");

delay(5000);

lcd.clear();

lcd.setCursor(3,0);

lcd.print("PROJECT");

delay(5000);

lcd.clear();

```
lcd.setCursor(5,0);  
lcd.print("Please");  
lcd.setCursor(2,1);  
lcd.print("Connect WiFi");
```

```
WiFiManager wm;  
wm.resetSettings();  
bool res;  
res = wm.autoConnect("MOHAMMED","12345678");
```

```
if(!res){  
  Serial.println("Failed to connect");  
  ESP.restart();  
}
```

```
lcd.clear();  
lcd.setCursor(2,0);  
lcd.print("Connected");  
delay(5000);  
lcd.clear();
```

```
dht.setup(25);
```

```
}
```

```
void loop() {
```

```
  for(int i = 0; i < 100; i++){
```

```
    volt_ch1 += analogRead(CH1);
```

```
  }
```

```
  volt_ch1 /= 100.0;
```

```
  volt_ch1 *= (VREF/4095.0);
```

```
  delay(dht.getMinimumSamplingPeriod());
```

```
  Humidity = dht.getHumidity();
```

```
  Temperature = dht.getTemperature();
```

```
  for(int i = 0; i < 100; i++){
```

```
    ldr += analogRead(35);
```

```
  }
```

```
  float Lux = ldr/100;
```

```
  lcd.clear();
```

```
  lcd.setCursor(0,0);
```

```
  lcd.print("PV Volt: ");
```

```
lcd.print(volt_ch1);
```

```
lcd.print('V');
```

```
lcd.setCursor(0,1);
```

```
lcd.print("T:");
```

```
lcd.print(Temperature);
```

```
lcd.print('C');
```

```
lcd.setCursor(9, 1);
```

```
lcd.print("L:");
```

```
lcd.print(Lux);
```

```
if (client.connect(server, 80))
```

```
{
```

```
String postStr = apiKey;
```

```
postStr += "&field1=";
```

```
postStr += String(volt_ch1);
```

```
postStr += "&field2=";
```

```
postStr += String(Lux);
```

```
postStr += "&field3=";
```

```
postStr += String(Temperature);
```

```
postStr += "&field4=";
```

```
postStr += String(Humidity);
```

```
postStr += "\r\n\r\n\r\n\r\n";

client.print("POST /update HTTP/1.1\n");
delay(100);
client.print("Host: api.thingspeak.com\n");
delay(100);
client.print("Connection: close\n");
delay(100);
client.print("X-THINGSPEAKAPIKEY: " + apiKey + "\n");
delay(100);
client.print("Content-Type: application/x-www-form-urlencoded\n");
delay(100);
client.print("Content-Length: ");
delay(100);
client.print(postStr.length());
delay(100);
client.print("\n\n");
delay(100);
client.print(postStr);
delay(100);
}

volt_ch1 = 0;

ldr = 0;
```

}