



**THE DESIGN AND CONSTRUCTION OF AN AC PROTOTYPE  
SYNCHRONIZATION SYSTEM USING GENERATOR AND INVERTER**

**BY**

<b>COSMAS, DENNIS AVWEROSUO</b>	<b>(ENG1805047)</b>
<b>DAUPHIN, MARVELOUS AYANTE</b>	<b>(ENG1704176)</b>
<b>EIFUOBHOKHAN, GODSWILL</b>	<b>(ENG1707810)</b>
<b>IRIBHOGBE, MOSES OSASOTA</b>	<b>(ENG1607637)</b>
<b>OBAZEE, PRECIOUS OSATOHANMWEN</b>	<b>(ENG1708906)</b>
<b>OBOZELE, EBOSETALE PRECIOUS</b>	<b>(ENG1704212)</b>
<b>OKPAKO, AVWEROSUOGHENE HENRY</b>	<b>(ENG1607917)</b>
<b>ONYEOMA, IKECHUKWU DIVINE</b>	<b>(ENG1707938)</b>

**THE DEPARTMENT OF ELECTRICAL/ ELECTRONIC ENGINEERING,  
FACULTY OF ENGINEERING,  
UNIVERSITY OF BENIN, BENIN CITY, EDO STATE.**

**SEPTEMBER, 2023**

**THE DESIGN AND CONSTRUCTION OF AN AC PROTOTYPE SYNCHRONIZATION  
SYSTEM USING GENERATOR AND INVERTER**

**BY**

<b>COSMAS, DENNIS AVWEROSUO</b>	<b>(ENG1805047)</b>
<b>DAUPHIN, MARVELOUS AYANTE</b>	<b>(ENG1704176)</b>
<b>EIFUOBHOKHAN, GODSWILL</b>	<b>(ENG1707810)</b>
<b>IRIBHOGBE, MOSES OSASOTA</b>	<b>(ENG1607637)</b>
<b>OBAZEE, PRECIOUS OSATOHANMWEN</b>	<b>(ENG1708906)</b>
<b>OBOZELE, EBOSETALE PRECIOUS</b>	<b>(ENG1704212)</b>
<b>OKPAKO, AVWEROSUOGHENE HENRY</b>	<b>(ENG1607917)</b>
<b>ONYEOMA, IKECHUKWU DIVINE</b>	<b>(ENG1707938)</b>

**SUBMITTED TO**

**THE DEPARTMENT OF ELECTRICAL/ ELECTRONIC ENGINEERING,  
FACULTY OF ENGINEERING,  
UNIVERSITY OF BENIN, BENIN CITY, EDO STATE.**

**IN PARTIAL FUFILLMENT OF THE REQUIREMENTS FOR THE AWARD OF  
BACHELOR OF ENGINEERING (B.ENG) DEGREE IN ELECTRICAL AND  
ELECTRONIC ENGINEERING**

**SEPTEMBER, 2023**

## CERTIFICATION

This is to certify that this project work was carried out by the aforementioned students stated in the previous page (II) in partial fulfilment of the requirement for the award of Bachelor of Engineering in the Department of Electrical and Electronic Engineering, Faculty of Engineering, University of Benin, Benin City, Edo State.

---

Engr. Prof J. O. Egwaile

(Project Supervisor)

---

Date

---

Engr. Prof. K.O. Ogbiede

(Head of Department)

---

Date

## **DEDICATION**

The project is dedicated to Almighty God and to our families who stood by us throughout this project's journey.

## **ACKNOWLEDGEMENT**

We would like to express our gratitude to Prof .J.O. Egwaile, our project supervisor, for dedicating, support and time spent meeting with us, providing valuable feedbacks, and guiding us through each stage of our project. It was a great learning experience. We collectively express our gratitude to Prof. E.A. Ogujor, Dean of Engineering, Prof. K.O Ogbeide, HOD Electrical/Electronics department, Prof. P.E Orukpe, Engr N.S. Idiagi and our course adviser Dr O.S. Omorogiuwa for their useful advice and suggestions. We also use this opportunity to appreciate all our families and friends for their financial support, perseverance and prayers which contributed massively to the successful completion of the project.

## **ABSTRACT**

The project presents a comprehensive exploration of synchronization technology in power generation and distribution systems. In an era characterized by increasing demands for efficient, reliable, and sustainable energy solutions, the development of synchronization systems plays a pivotal role in ensuring seamless integration of diverse power sources. This project endeavours to bridge the gap between theory and practical implementation by designing, constructing, and evaluating a prototype synchronizing system.

This work involves the designing of a 2KVA inverter and a synchronizing circuit used to parallel the connection between the inverter and a AC generator to produce a higher power voltage to carry a load greater than the individual rating of the inverter and the generator, using an oscilloscope to read the phase waveform and frequency of both the inverter and generator, with a voltmeter display showing the voltage. The voltage and frequency of both power sources are manually regulated to ensure both power sources are aligned before the circuit breaker acting as the switch for current flow to the supply outlet where the load is connected. The power sources are connected together in a series connection, and a current doubler is connected to the synchronizing system to ensure the output voltage from the synchronizing system which ranges from 350-400 volts is effectively mitigated resulting in a consistent and stable output voltage of 220volts.

The construction of a prototype synchronization system was tested by manually varying the frequency and voltage of the generator and ensuring they are matched at a value of approximately 50Hz, 220V, before opening the connected outlet which supplies power to a 2500W pressing iron acting as the load. The load draws a current of about 5-6Amps from each individual power source in contrast with a current of about 9-10Amps flowing through the pressing iron. Ultimately, this project seeks to contribute to the ongoing evolution of synchronization challenges, offering a valuable foundation for future research and practical implementations.

## TABLES OF CONTENT

CERTIFICATION .....	II
DEDICATION .....	III
ACKNOWLEDGEMENT .....	IV
ABSTRACT .....	V
TABLES OF CONTENT .....	VI
TABLES OF FIGURE .....	IX
CHAPTER ONE .....	1
INTRODUCTION .....	1
1.1 Background To Study .....	1
1.2 Statement Of Problem .....	2
1.3 Aim .....	2
1.4 Objectives .....	2
1.5 Methodology .....	2
1.6 Significance of Study .....	3
1.7 Outline of the Project Report .....	3
CHAPTER TWO .....	4
LITERATURE REVIEW .....	4
2.1 Forms Of Grid Synchroscope .....	4
2.1.1 Electronic Synchroscope .....	4
2.1.2 Electro-mechanical Synchroscope .....	5
2.2 Working Principle of a General Synchroscope .....	5
2.2.1 Synchroscope Circuit Diagram .....	6
2.3 Types Of Synchrosopes .....	6
2.3.1 Electrodynamometer Synchroscope .....	7

2.3.2 Moving Iron Synchroscope .....	8
2.4 Summary Of Component Required For The Design Of Ac Synchroscope Prototype .....	8
2.4.1 PIC Microcontroller .....	9
2.4.2 Transformer .....	9
2.4.3 MOSFET (IRFB4110Pbf) .....	10
2.4.4 Contactors .....	11
2.4.5 Push Buttons .....	11
2.4.6 Relay .....	12
2.4.7 Crystal Oscillators .....	12
2.4.8 Potentiometers .....	13
2.5 Discuss Synchronization Techniques .....	14
2.6 Need For Synchronization of Grid Sources .....	14
2.7 Review of Related Works .....	15
CHAPTER THREE .....	16
DESIGN METHODOLOGY .....	16
3.1 Block Diagram of the Synchroscope Prototype System .....	16
3.2 Design Considerations .....	16
3.2.1 The Inverter Block .....	17
3.2.2 Ac Mains Block .....	23
3.2.3 Synchronous Block .....	23
3.2.4 Display Block .....	24
3.2.5 Relay Block .....	24
3.2.6 Current Booster Block .....	25
3.2.7 Load Output Block .....	26
3.3 Synchroscope Circuit Diagram .....	27
3.4 Principle of Operation .....	27

CHAPTER FOUR.....	29
CONSTRUCTION TESTING AND RESULT ANALYSIS .....	29
4.1 Construction.....	29
4.2 Simulation.....	29
4.3 Acquisition of Components.....	32
4.4 Printed Circuit Board Design.....	32
4.4.1 ARES Layout Editor Features.....	32
4.5 Soldering and Build Up.....	33
4.6 Microcontroller Programming.....	34
4.6.1 Compiler.....	34
4.6.2 Programmer.....	35
4.7 Packaging.....	36
4.8 Step by Step Design Procedure.....	37
4.9 Testing and Result Analysis.....	38
4.9.1 Test condition one (Load Current Less Than 5A).....	38
4.9.2 Test condition two (Load Current Exceeds 5A).....	38
4.10 Bill Of Engineering Measurements And Evaluation (BEME) As AT September, 2023 ....	40
CHAPTER FIVE .....	43
CONCLUSION AND RECOMMENDATION.....	43
5.1 Conclusion.....	43
5.2 Limitations Of The Work.....	44
5.3 Recommendations.....	44
REFERENCES.....	46

## TABLES OF FIGURE

- Figure 2.1:** Diagram of an Electronic Synchroscope
- Figure 2.2:** Diagram of an Electromechanical Synchroscope
- Figure 2.3:** Circuit Diagram of a Synchroscope.
- Figure 2.4:** Diagram Of An Electrodynamometer Synchroscope
- Figure 2.5:** Diagram Of A Moving Iron Synchroscope
- Figure: 2.6:** PIC Microcontroller
- Figure: 2.7** Transformer.
- Figure: 2.8** IRFB4110Pbf MOSFET
- Figure 2.9:** Contactor
- Figure 2.10:** Push Buttons
- Figure 2.11:** Relay module for socket outlets
- Figure 2.12:** Crystal Oscillator
- Figure 2.13:** Potentiometers
- Figure 3.1:** Block diagram of the synchroscope prototype system
- Figure 3.2:** Inverter Block
- Figure 3.3:** Sine Wave Oscillator Flow Diagram
- Figure 3.4:** Schematic Representation of the H-bridge
- Figure 3.5:** Typical Connection for IRFB4110Pbf MOSFET Driver
- Figure 3.6:** Inverter Circuit Diagram
- Figure 3.7:** LCD circuit diagram

**Figure 3.8:** Transistor and Relay Circuit Diagram

**Figure 3.9:** Current Booster

**Figure 3.10:** Synchroscope Circuit Diagram

**Figure 4.1:** Simulation of synchronizing circuit

**Figure 4.2:** Simulation of inverter circuit

**Figure 4.3:** PCB Design Top

**Figure 4.4:** Soldering and Build Up

**Figure 4.5:** Microcontroller Programming

**Figure 4.6:** Proposed Packaging

**Figure 4.7:** Views of the inverter

**Figure 4.8:** Test Condition One

**Figure 4.9:** Test Condition Two

**Figure 4.10:** Synchronization complete

## CHAPTER ONE

### INTRODUCTION

#### 1.1 Background To Study

It is true that in many parts of Nigeria, the mains AC supply can be unreliable, leading to power outages and disruptions in productivity. As a result, energy consumers often resort to using alternative sources of power supply, such as generators, solar panels, or inverters, in conjunction with the mains AC supply to ensure continuous power availability.

Synchronization of these power sources is indeed crucial to optimize power usage and prevent downtime. Here are some reasons why synchronization is important:

**Seamless Power Transition:** When multiple power sources are used together, synchronization ensures a smooth transition between the mains AC supply and the alternative sources. This avoids sudden power fluctuations or interruptions, which can damage sensitive electronic devices or disrupt operations.

**Load Sharing:** Synchronization allows for the load to be shared efficiently among different power sources. This ensures that no single source is overloaded while others remain underutilized, maximizing the overall efficiency and stability of the power supply system.

**Frequency and Voltage Regulation:** Power sources need to generate electricity at a specific frequency (usually 50Hz in Nigeria) and voltage level to match the mains AC supply. Synchronization ensures that all sources produce power within acceptable parameters, avoiding potential damage to electrical appliances and equipment.

**Fuel Efficiency:** In the case of generators, synchronization helps in optimizing fuel consumption. When multiple generators are synchronized, they can work together to meet the required load demand, reducing fuel wastage and operating costs.

**Reducing Emissions:** Synchronization can also contribute to a reduction in carbon emissions and environmental impact. By optimizing power generation and load sharing, the reliance on fossil fuel-powered generators can be minimized, and cleaner energy sources like solar and battery storage can be used effectively.

Synchronization is the process of matching the frequency, phase, and voltage of a generator or other source to an electrical grid in order to transfer power in an alternating current (AC) electric power system. Two disconnected grid segments cannot safely interchange AC power until they are synchronized, even if they are connected to one another.

## **1.2 Statement Of Problem**

AC synchronizing systems play a crucial role in achieving the necessary synchronization between distributed power sources and the grid. In a scenario where the required load demand is greater than the power capacity of the available distributed power sources, it is not possible for power from the electrical power supply systems to conveniently provide the required load demand unless both power sources are synchronized. For synchronization to occur between two power sources the voltage, frequency and phase angle of both system should match. The synchronization system ensure that the frequency, phase, and voltage of the distributed power sources align with the parameters of the electrical power grid, enabling seamless operation and efficient power sharing. Without proper synchronization, the integration of distributed power sources can lead to power imbalances, system instability, and even damage to equipment.

## **1.3 Aim**

The primary aim of this project is to design and construct a prototype AC synchronizing system that addresses the challenges associated with synchronizing distributed power sources.

## **1.4 Objectives**

1. To synchronize a 2kva inverter and 1kva generator
2. To aid the synchroscope in handling a load of 3kva
3. To ensure that the output voltage and frequency of the inverter closely matches the generator
4. To test the designed system

## **1.5 Methodology**

To achieve the objectives of designing and constructing the prototype AC synchronizing system, a comprehensive methodology is adopted. Such as

1. Literature Review
2. Anticipated physical phenomena during the Synchronization
3. System Design and Simulation
4. Construction and Testing

### **1.6 Significance of Study**

The integration of distributed power sources into electrical power systems offers numerous benefits, including the potential for renewable energy penetration, improved energy efficiency, and reduced greenhouse gas emissions. Realizing those benefits relies heavily on the successful synchronization of distributed power sources with the grid. The prototype AC synchronizing system developed in this project holds significant importance in the following ways mentioned above

### **1.7 Outline of the Project Report**

- Chapter one is a brief introduction to the project work.
- Chapter two reviews the literature of the work it focuses on related works and the theory of the technology used in this project.
- Chapter three presents the methodology for the work.
- Chapter four addresses the results of the implemented works.
- Chapter five is the conclusion of the project.

## CHAPTER TWO

### LITERATURE REVIEW

#### 2.1 Forms Of Grid Synchronoscope

A synchronoscope comes in two different designs

1. Electronic
2. Electro-mechanical

##### 2.1.1 Electronic Synchronoscope

An electronic synchronoscope is a device used in power systems to compare the frequency and phase angle of two alternating current (AC) systems. It helps to determine if the two systems are synchronized or not. The synchronoscope displays the phase difference between the systems and provides valuable information for safely connecting or disconnecting them, especially in power generation and distribution applications.

The electronic synchronoscope has the following features.

1. Continuous, maintenance-free functionality.
2. There are no moving parts.
3. Less energy is required.
4. Visible in the dark



Figure 2.1: Diagram of an electronic synchronoscope

### 2.1.2 Electro-mechanical Synchroscope

An electro-mechanical synchroscope is a device used in electrical engineering to indicate the phase difference and frequency deviation between two alternating current (AC) systems. It typically consists of a rotating disc with indicators that show the synchronization status of the two AC sources. By observing the relative positions of the indicators, engineers can determine whether the systems are in-phase or out-of-phase and make adjustments accordingly to achieve synchronization



Figure 2.2: Diagram of an Electromechanical synchroscope

Features of the electromechanical synchroscope are as follow

1. Incredibly sturdy build quality.
2. Ability can be serviced quickly and easily.
3. Broad range of acceptable input voltage

### 2.2 Working Principle of a General Synchroscope

The operation of a synchroscope is similar to that of an AC motor. When the frequency of the incoming generator and the running generator deviate from one another, the synchroscope rotates. Its layout calls for the incoming frequency to be higher than the operating frequency. Only when the incoming frequency exceeds the running frequency does the synchroscope's pointer rotate in a clockwise direction.

A synchronometer is made of a rotor and a two-phase stator. The Synchroscope receives the necessary two-phase power from the alternators.

When the first two phases are in sync, the third phase will follow. The stator of the Synchroscope receives power from the existing alternator. The incoming alternator supplies power to the rotor. The reverse of the frequency difference between the paralleled alternators is the same as the phase difference between the aforementioned power sources.

When the alternators with different frequencies are connected together and turned on, the device starts working to display the required parameters. The rotor will cease rotating and the dials will remain stationary when the stator and rotor have the same frequency. In reaction to a change, the dials tilt as the rotor starts to rotate due to a change in the frequency at which the stator and rotor are supplied. The difference in supply frequency directly relates to the rotational speed of the rotor. The rotor spins faster as the gap widens. The rotor's rotating velocity decreases as the gap grows smaller.

### 2.2.1 Synchroscope Circuit Diagram

The circuit diagram for a synchroscope is displayed below. It consists of rotor windings and a two-phase stator. A phase splitting network is used to coil the two stator windings at a right angle to one another. This indicates that a rotating magnetic field is produced when the currents of two phases are directed at an angle of 90 degrees. The running generator/alternator is connected to a polarized coil, and the stator winding is connected to the incoming generator/alternator.

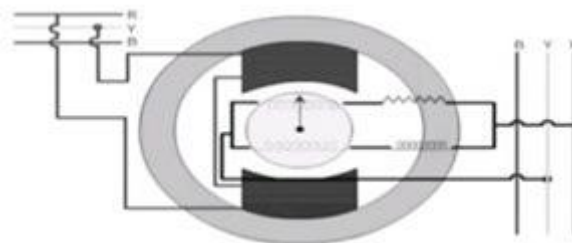

Figure 2.3: Circuit Diagram of a Synchroscope.

### 2.3 Types Of Synchrosopes

They are two types of synchroscope

1. Electrodynamometer synchroscope
2. Moving iron synchroscope

### 2.3.1 Electrodynamicometer Synchroscope

It consists of static and dynamic parts, which are the main parts of this type of synchroscope. The circuit diagram of the electrodynamicometer synchroscope is shown below. One of the transformer windings is excited by the bus bar and the remaining two windings of the transformer are excited by the incoming machine. The transformer's central limb has a lamp connection to determine the synchronization of frequencies.

The basic components of this kind of synchroscope are static and dynamic portions. The electrodynamicometer synchroscope's circuit diagram is displayed below. The bus bar excites one of the transformer windings, while the incoming machine excites the other two windings of the transformer. A light connection on the transformer's central limb allows for the measurement of frequency synchronization. When the incoming machines' voltages are out of phase with one another, the lamp won't light up. In this instance, the resultant flux at the transformer's central limb is zero. If the frequencies of the bus bar and the incoming machines are not the same, the lamp begins to flicker. The difference in frequency between the incoming machines and the bus bar is equivalent to the frequency of the flickering or blazing lamp.

If the lamp provides maximum brightness with the least amount of flickering, the incoming machine and the bus bar are considered to be in sync. An electrostatic gadget indicates the arriving machines' speed.

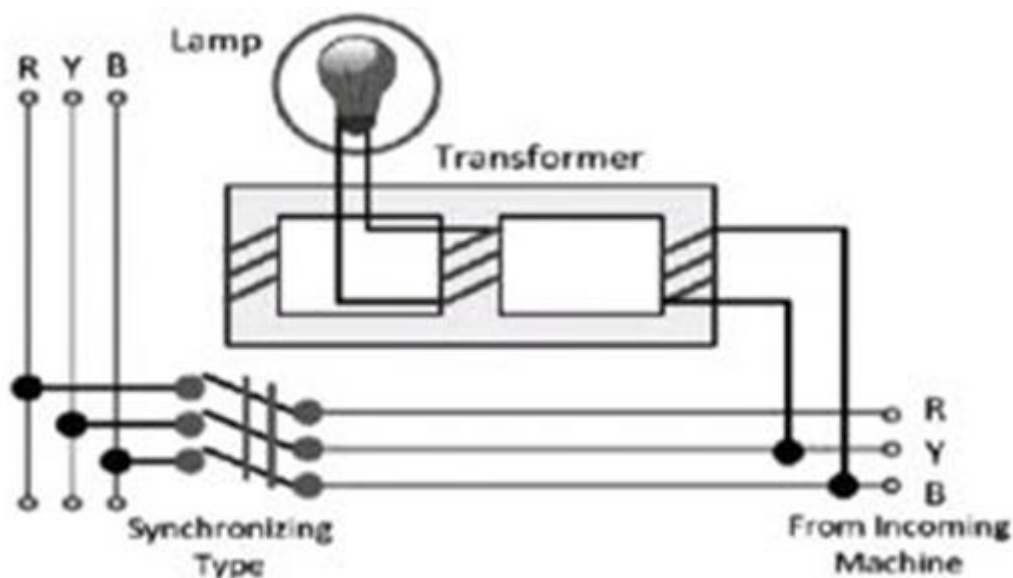

Figure 2.4: Diagram Of An Electrodynamicometer Synchroscope

### 2.3.2 Moving Iron Synchroscope

There are two fixed coils in it. There is a modest current value with series resistance in one of the fixed coils. The pressure coil powers the two cylinders, which are positioned on the spindle. Pressure coils that are connected to one another are present in the two phases of the entering machinery. A 90 degree phase difference between the two pressure coils is produced by the resistance and inductance linked in series with the pressure coils.

If the bus bar and the incoming machines have the same frequency, the synchroscope's spindle or pointer will begin to rotate. The spindle's number of revolutions per second is utilized to calculate the frequency discrepancies between the bus bar and the incoming machines.

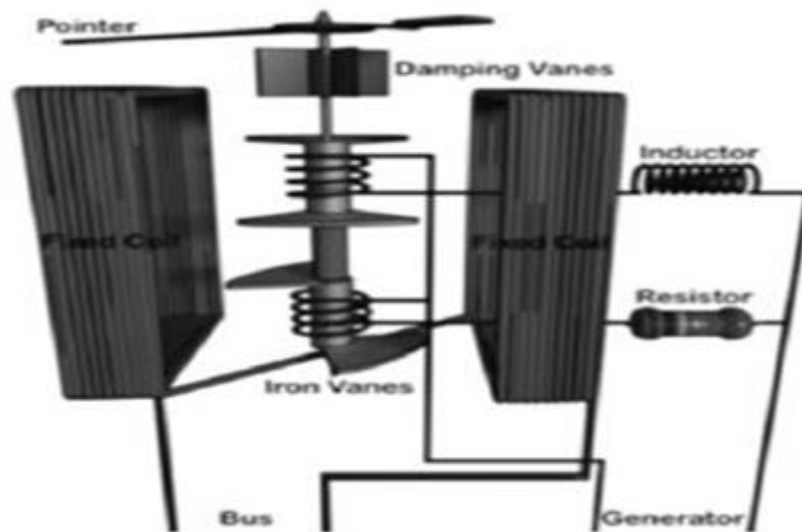

Figure 2.5: Diagram Of A Moving Iron Synchroscope

### 2.4 Summary Of Component Required For The Design Of Ac Synchroscope Prototype

The following sections contain a list and discussion of the parts needed to design an AC synchroscope prototype.

- PIC Microcontroller
- Transformer
- Metal Oxide Field Effect Transistors (MOSFET) IRF3205
- Contactors

- Push Buttons
- Relay
- Crystal Oscillator
- Potentiometer

### 2.4.1 PIC Microcontroller

PIC microcontroller may utilize real time operating systems such as FreeRTOS, AVIX RTOS, Utros, Salvo RTOS or other similar libraries for task scheduling and prioritization.

PIC devices are popular with both industrial developers and hobbyists due to their low cost, wide availability, large user base, an extensive collection of application notes, availability of low cost or free development tools, serial programming, and re-programmable flash-memory capability. The PIC microcontroller used in this project is the PIC18F4550. One of the most widely used micro-controllers, it has nano-Watt technology and a high-performance flash memory interface through USB. This 8-bit microcontroller is widely used in a variety of industries and is favoured by creators and engineers alike (24 September, 2018). The symbol for PIC18F4550 is illustrated below:



Figure 2.6: PIC Microcontroller

### 2.4.2 Transformer

Transformers take alternating current electricity and send it to another circuit, where the voltage is either increased (stepped up) or decreased (stepped down). To operate low-voltage devices like doorbells and toy electric trains, transformers are employed to reduce the voltage of conventional power circuits. This allows for long-distance transmission of electric power from electric generators.

The magnetic lines of force (flux lines) in the primary coil expand and contract in response to the alternating current, causing a current to be induced in the secondary coil. The secondary voltage may be calculated by multiplying the voltage across the primary coil by the turns ratio (the number of turns in the secondary coil divided by the number of turns in the main coil).

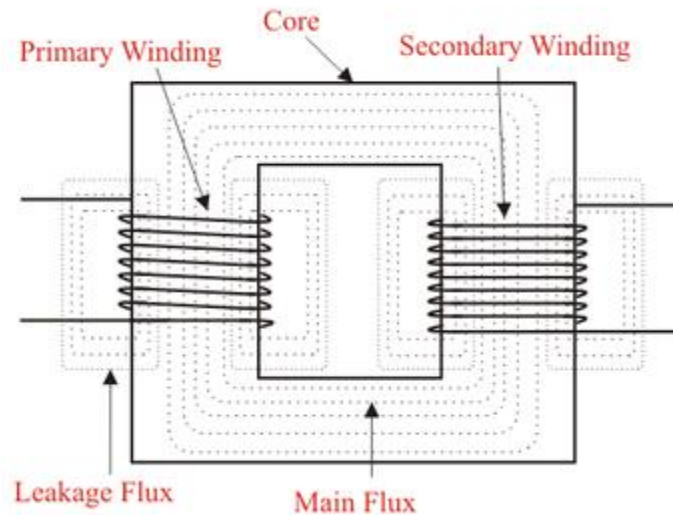

Figure: 2.7: Transformer.

### 2.4.3 MOSFET (IRFB4110Pbf)

MOSFET are a kind of field-effect transistor (FET with an insulated gate) whose conductivity is controlled by an applied voltage. A signal amplifier or switch uses this. Electronic signals may be amplified or switched using materials whose conductivity varies in response to the applied voltage.

As a high-current N-Channel MOSFET, the IRFB4110Pbf can handle switching currents of up to 120A at 100V. The MOSFET is ideal for switching circuits such as inverters, motor speed controllers, DC-DC converters, etc. because of its low on resistance of just 4.5mΩ. As an additional bonus, it has a low on-resistance and is one of the inexpensive MOSFETs that can be found in plenty. It is important to note that the voltage level of the microcontroller output pin should match the gate threshold voltage of the IRFB4110Pbf MOSFET.

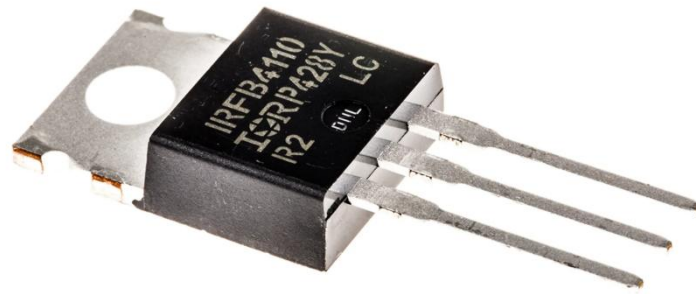

Figure: 2.8: IRFB4110PbF MOSFET

#### 2.4.4 Contactors

An alternating current (AC) contactor is a device used to turn on and off an electrical circuit. Our AC contactors come with a variety of mounting options, contact types, current/voltage ratings, and auxiliary contact configurations. They come in a wide variety of voltages, from 12V AC/DC to 690V AC/440V DC. The power used by the contactor coil is lowered by using economizer circuits. Products from the KILOVAC and HARTMAN brands are among those we provide for AC contactors.



Figure 2.9: Contactor.

#### 2.4.5 Push Buttons

In order to activate the internal switching mechanism of a push button switch, the user must physically press the switch's button. They may be found in a wide range of sizes and configurations to meet a wide range of needs in design.



Figure 2.10: Push Buttons

### 2.4.6 Relay

A relay is an electromechanical switch that may open or shut a circuit. The contacts of a relay may be opened or closed to activate a single electrical circuit. A typically open relay contact means that the circuit's current route is not closed. When the relay contact is normally closed there is a closed circuit path for current to flow through, hence it can effectively connect or disconnect certain loads and circuits when its coils are energized or de-energized.

The relay works with the push button and serves as a switch, turning it on starts the synchronization.



Figure 2.11: Relay module for socket outlets

### 2.4.7 Crystal Oscillators

An electrical oscillator circuit that employs a piezoelectric crystal as the frequency selector is called a crystal oscillator. Timekeeping devices like quartz wristwatches, digital integrated circuits in need of a reliable clock signal, and radio equipment in need of frequency stability all make use of oscillators. Quartz crystals are the most widely utilized form of piezoelectric resonator, leading to the moniker "crystal oscillators" for oscillator circuits that use them. Quartz crystals have a feature

known as inverse piezoelectricity, which allows them to slightly alter their form when subjected to an electric field. The crystal's form is modulated by applying a voltage to its electrodes, and when the voltage is withdrawn, the crystal creates a little voltage as it returns to its original shape elastically. Quartz behaves like an RLC circuit, but with a significantly greater Q factor, oscillating at a steady resonant frequency (less energy loss on each cycle of oscillation). Quartz crystals have excellent frequency stability after they have been tuned to a certain frequency (which is determined by the mass of electrodes linked to the crystal, the orientation of the crystal, temperature, and other variables).



Figure 2.12: Crystal Oscillator

### 2.4.8 Potentiometers

An electrical potentiometer is a passive component. To adjust a potentiometer's setting, you move a sliding contact across a fixed resistance. The output voltage of a potentiometer is equal to the difference in potential between its fixed and sliding contacts, which is the same as the input voltage. On one end of a resistor in a potentiometer are the two input terminals. The output voltage is changed by moving the contact along the output side resistor.

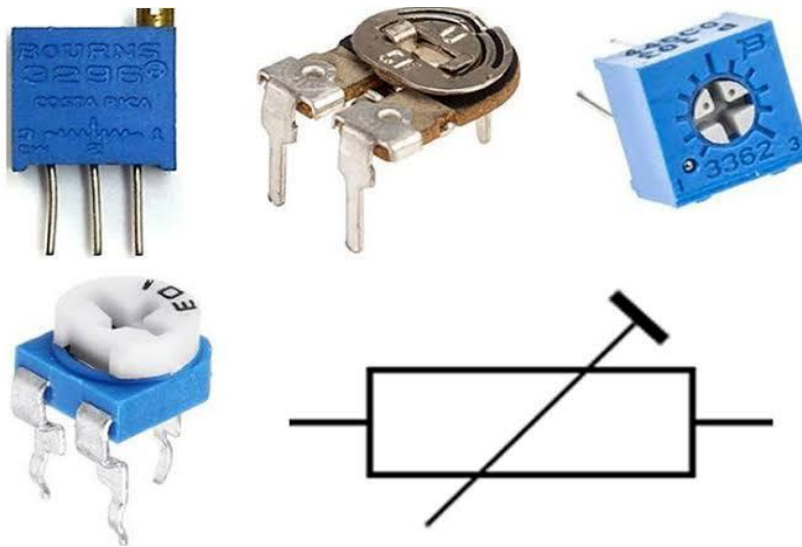

Figure 2.13: Potentiometers

## 2.5 Discuss Synchronization Techniques

**Lamp Method;** Connect the three lights and a voltmeter to the alternator's terminal as indicated in the picture above; using the two-bright-lamp and one-dark-lamp technique, the voltage must be the same as the bus-or bar's raised by adjusting the alternator's field current until the two voltages are equal. test whether or whether the light bulb flickers in a clockwise or counter-clockwise direction.

When comparing the incoming generator's rotational speed to the bus bar's or the running generator's, a slow counter-clockwise rotation indicates a sluggish entering generator and a rapid clockwise rotation indicates a high generating speed. The flickering of the bulb may be minimized by adjusting the alternator's speed, and the breaker can be closed at the precise time when the phase-connected bulb goes black while the other two remain light.

**Microcontroller method (use code interrupt);** the microcontroller is used in this particular synchronization technique, this involves coding the microcontroller

## 2.6 Need For Synchronization of Grid Sources

- To improve efficiency
- To increase power output
- For load compensation, so as to handle more load

## 2.7 Review of Related Works

Muhammad (2021) wrote a thesis on Single phase smart grid tie inverter he proposed the design of a 250w grid connected single stage inverter. The design was simulated on a Matlab software

Vivek et al. (2020) wrote a paper on the visualization of synchroscope using synchrophasors. The research presents a novel application of synchrophasors for remote visualization of synchroscope while facilitating synchronization of two large grid for the creation of the integrated synchronous national grid of India.

Patil et al. (2015) published a design and fabrication article titled "Design and Fabrication of Synchronizing Panel for Parallel Operation of Alternators." The planning and execution of synchronization devices is the focus of this study. A synchronizing panel that may facilitate the functioning of alternators in parallel has been successfully developed, and it is anticipated that this panel will be of great service. We feel that using a synchronization panel delivers superior results based on the results of pre-tests that were conducted without the panel and assessments.

Nader et al. (2012) proposed a research on the synchronization of renewable energy inverters with the grid. It proposed the design of a new all-digital circuit topology for synchronizing an inverter to the grid. The circuit not only can synchronize an inverter to the grid but also can regain synchronization whenever it is lost such as after an unanticipated perturbation in the phase, amplitude, or distortion of the grid voltage. The proposed circuit is based on the digital phase lock loop (DPLL) which has been extensively used in communications and signal processing systems that require phase tracking and synchronization.

Neshti et al. (2010) used MATLAB SIMULINK to create a virtual model for automatic synchronization of an infinite busbar alternator. The team utilized MATLAB SIMULINK to build and implement a virtual model for the real-time synchronization of an infinite bus bar and an alternator. MATLAB SIMULINK is used to keep tabs on a number of factors in addition to the synchronization itself, including voltage, frequency, phase angle, and phase sequence. In order to accurately and reliably monitor, measure, and run synchronous generators in parallel, an automated synchronization unit was designed.

Thompson (2012) described the Fundamentals and Advancements in Generator Synchronizing Systems. In his paper, he outlined how the use of microprocessors built to protective-relay standards may streamline synchronization circuits, all while cutting down on complexity, increasing reliability, and making full system automation, integration, and remote control very painless.

## CHAPTER THREE

### DESIGN METHODOLOGY

A synchroscope prototype system is designed by following basic electronic principles and the design is discussed in this chapter.

#### 3.1 Block Diagram of the Synchroscope Prototype System

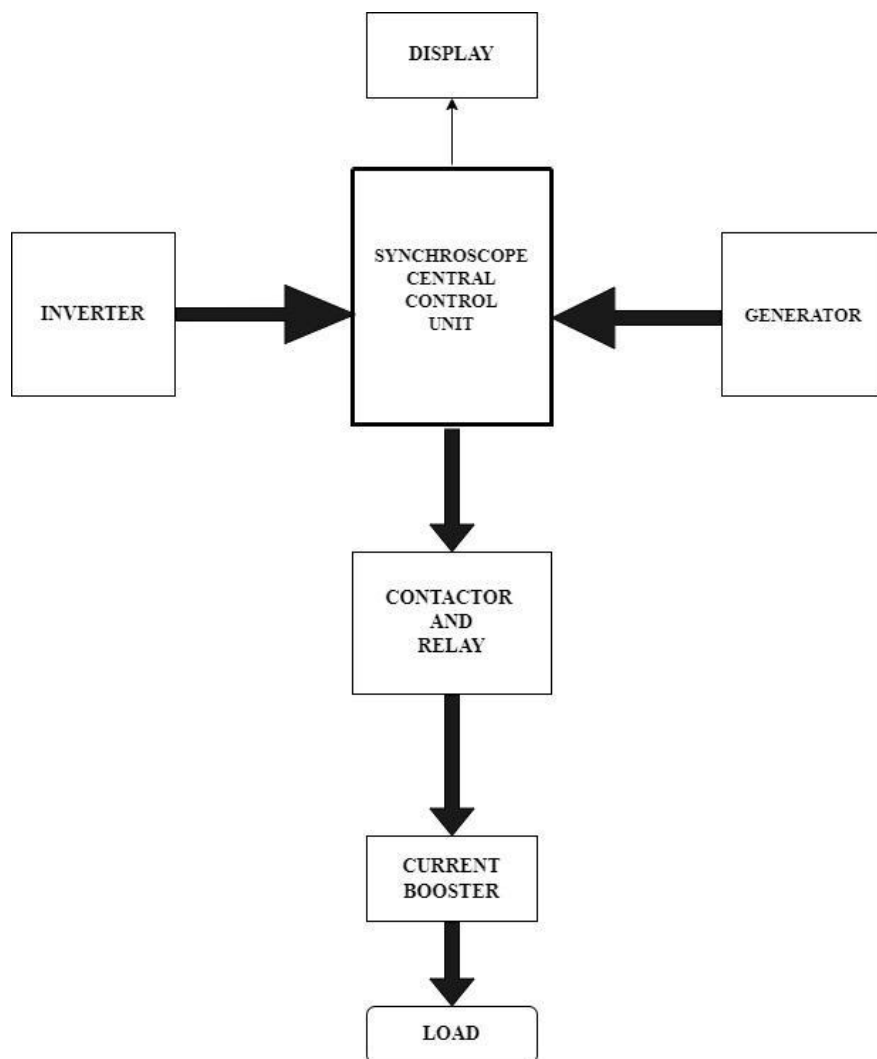

Figure 3.1 Block diagram of the synchroscope prototype system

#### 3.2 Design Considerations

This project design includes the following block

1. The inverter block

2. AC Mains
3. Synchroscope control unit block
4. Display block
5. Contactor relay block
6. Current booster block
7. The load outlet block

Each of these blocks are shown in the diagram above, Fig 3.1 and shall be discussed below in the step-by-step procedure for the design of the project.

### 3.2.1 The Inverter Block

Power inverters are devices which can convert electrical energy of DC form into that of AC. The figure below shows the block representation of an inverter

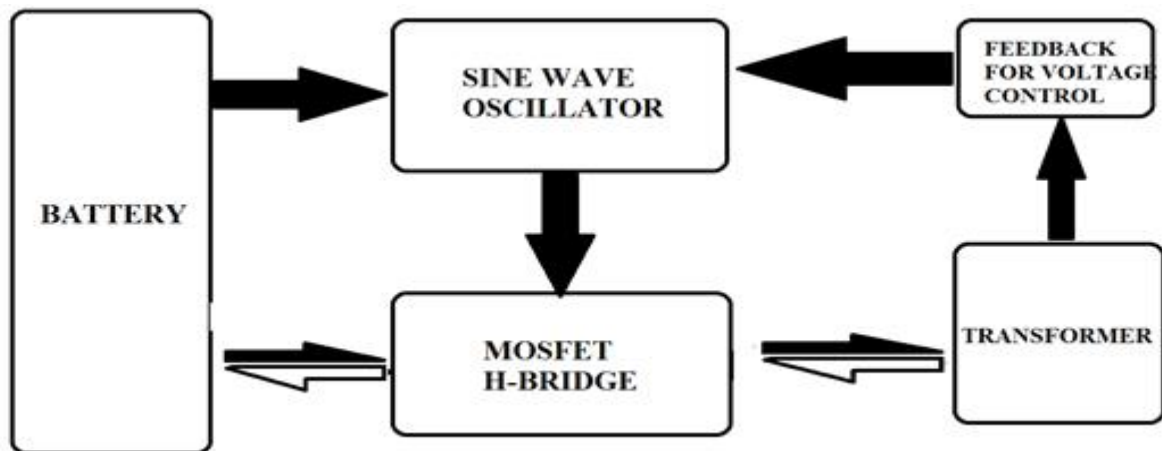

Figure 3.2: Inverter Block

The inverter block is made up of the following sub-systems.

- Battery
- Sine Wave Oscillator
- MOSFET H-Bridge

- Transformer
- Feedback for Voltage Control

### 3.2.1.1 Battery

Inverters are used to convert electrical energy in DC form to AC form. This electrical energy in DC form is gotten from the inverter battery, which stores electrical energy in DC form. The inverter utilises two 12V 200Ah wet cell batteries for its operation, which are series together to produce a resulting 24V DC input. The energy stored in the battery is converted from its DC form to a sinusoidal AC output at 220V through the process of inversion.

### 3.2.1.2 Sine Wave Oscillator

- An electronic oscillator is a circuit designed to generate a recurring oscillating signal. In this setup, we utilize a microcontroller known as the dsp30f2010 (referred to as the SLAVE controller) to produce a sinusoidal oscillation. Specifically, the dsp30f2010 is a 16-bit programmable microcontroller equipped with 512Kb of program memory. It functions by generating Pulse Width Modulated (PWM) outputs that exhibit variations in duty cycle resembling a sinusoidal pattern. To ensure the smoothness of the waveform, the duty cycle values are programmed using a lookup table based on a sine wave. Additionally, we can determine the required sample rate for achieving a specific output frequency using the following equation.
- Sample Rate is calculated as Output Frequency X Samples..... (3.1).

The intended sample rate is 3.2 kilo samples per second, or  $50 \times 64 = 3200$  samples per second ..... (3.2)

By adjusting either the sample rate or the number of samples, as shown in equation 3.2 above, any desired output frequency may be produced. For example,

$$\text{Output Frequency} = \frac{\text{Sample Rate}}{\text{Number of samples}} \dots\dots(3.3)$$

A 64 point Look-up table (LUT) that resembles a sine wave is produced. The following formula is used to generate the look-up table sample data:

- Value  $n$  = Sample number (range: 0 to 63) .....(3.4)
- Full Scale is equal to the Digital Analogue Converter (DAC) full scale count, which for 8-bit micro-controllers is 127.
- Zero = The value at which an 8-bit micro-controller's DAC generates 0 volts, or 127.
- Using the previous equation 3.4, the next ATMEGA328p microcontroller creates and stores the values of the look-up table as an array in its ROM memory.
- SineTable64 [array] = 127, 139, 152, 164, 176, 187, 198, 208, 217, 225, 233, 239, 244, 252, 253, 254, 253, 252, 249, 244, 239, 233, 225, 127, 115, 102, 90, 78, 67, 56, 46, 37, 29, 21, 15, 10, 5, 2, 1, 0, 1, 2, 5, 10, 15, 21, 29, 37, 46,
- The formula for calculating the maximum output frequency is;
- Maximum Sample Rate / Number of Samples = Maximum Output Frequency..... (3.5)
- An 8-bit DAC maximum sample rate is 125 Kbps.
- For an 8-bit DAC, the maximum number of samples is 256.
- The highest achievable output frequency is 488 Hz.
- Consequently, the microcontroller may output at a maximum frequency of 488 Hz.
- The main instruction commands are carried out as soon as the microcontroller is powered on, loading all hardware configurations from the device configuration. The actions listed below are carried out.
- Counter16 has begun.
- interrupt counter 16 is active
- High power is used to start the 8 bit DAC.
- There is a global interrupt enabled. Only if the Global Interrupt is enabled will any interrupt in

the code be handled.

- The lookup table's reference is initially set to 0.
- Then, an endless loop starts. From this point forward, every operation happens inside the interrupt service routine (ISR) of the Counter.
- The ISR of the Counter is used to read from the lookup table and write to the DAC. The activities are carried out using the function Counter. The following code declares this function as an interrupt handler. The Counter ISR receives the interrupt when the counter interrupt occurs. The interrupt handler takes over control from here. Inside the ISR, the following operations happen.
- It reads the value from the lookup table that matches the pointer.
- This value is added to the DAC.
- It increases the Pointer.
- Pointer is reset to 0 if Pointer is greater than 64, starting the subsequent cycle with the first sample in the look-up table.

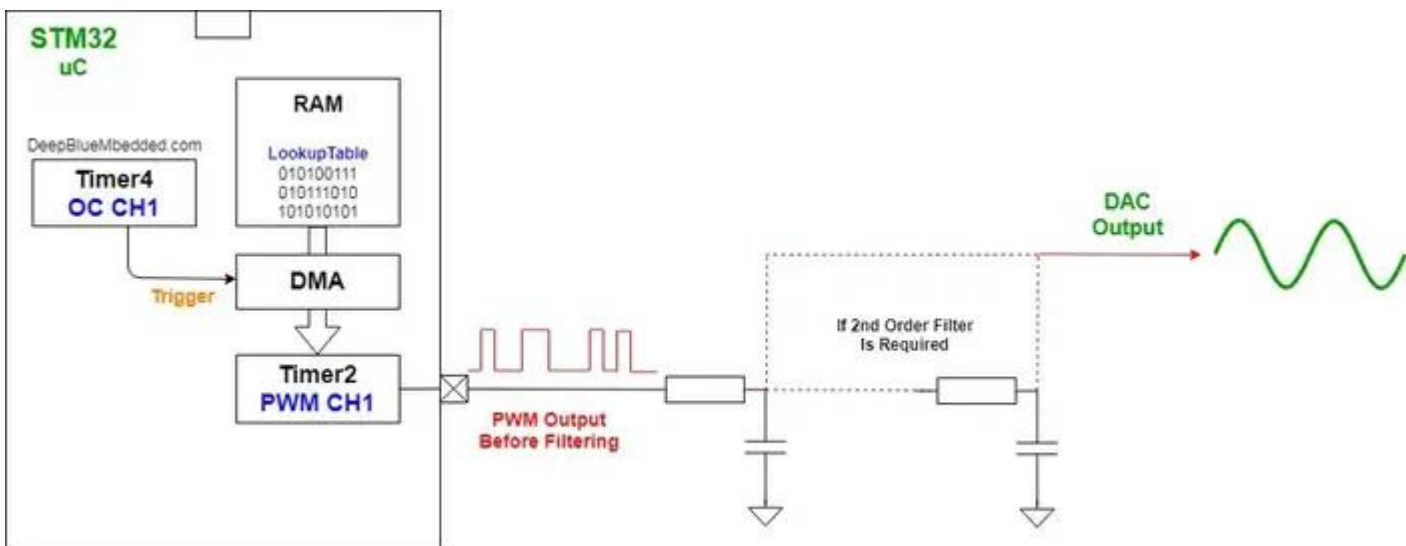

Figure 3.3: Sine Wave Oscillator Flow Diagram

### 3.2.1.3 MOSFET H-Bridge

Generating a sine wave centred on zero volts requires both a positive and negative voltage across the load, for the positive and negative parts of the wave, respectively. This can be achieved from a single source through the use of four MOSFET switches arranged in an H-Bridge configuration. To minimize power loss and utilize higher switching speeds, N-Channel MOSFETs were chosen as switches in the bridge. Level translation between PWM signals and voltages required to forward bias high side N-Channel MOSFETs, the IRFB4110Pbf MOSFET driver integrated circuit was chosen. A diagram of the H-Bridge circuit with MOSFETs and drivers is shown in Figure 3.11.

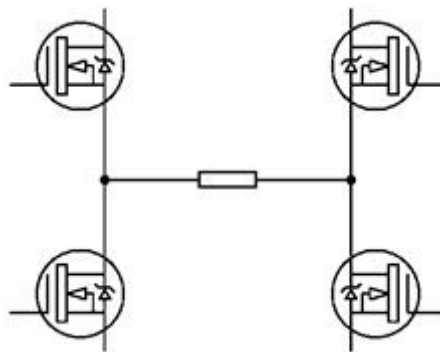

Figure 3.4: Schematic Representation of the H-bridge

The power rating of the inverter is taken into account when determining how many MOSFETs are needed for the H-bridge architecture. The inverter has a 2000VA rating, and the MOSFET's  $V_{dss}=100V$ ;

$$\text{Load Current (I}_L\text{)} = \frac{2000}{100} = 20 \text{ Amps} \dots\dots\dots (3.6)$$

This is the Current to be handled by the MOSFET

The MOSFETs are selected with voltage ratings anywhere not less than the battery voltage root mean square (RMS) value as its Drain-Source Voltage (VDSS) i.e.

$$V_{dss} > V_{\text{battery}} \times \sqrt{2} \dots\dots\dots (3.7)$$

$$V_{dss} > 12 \times \sqrt{2} \dots\dots\dots (3.8)$$

$$V_{dss} > 16.97V \dots \dots \dots (3.9)$$

The continuous drain current ( $I_D$ ) = Load Current = 20A

To ensure proper management of current each side of the H-bridge must be able to have at least 1.5 times the current i.e.

$$20Amps \times 1.5 = 30A \dots \dots \dots (3.11)$$

The IRFB4110Pbf Low and High Side Drive device has the capacity to handle voltage of up to 500V at a current rating of 2A at fast switching speeds. It surpasses all necessary demand for driving the MOSFETs in the bridge. This device is required to drive the high side MOSFETs in the circuit selected HO, due to the fact that the gate to source voltage must be greater than the drain to source voltage, which is the maximum voltage in the system. This device uses a bootstrapping capacitor to maintain a voltage difference of approximately 10V above the drain to source voltage. Two devices are utilized in a full bridge configuration. A typical connection of a single IRFB4110Pbf device is shown in Figure 3.12.

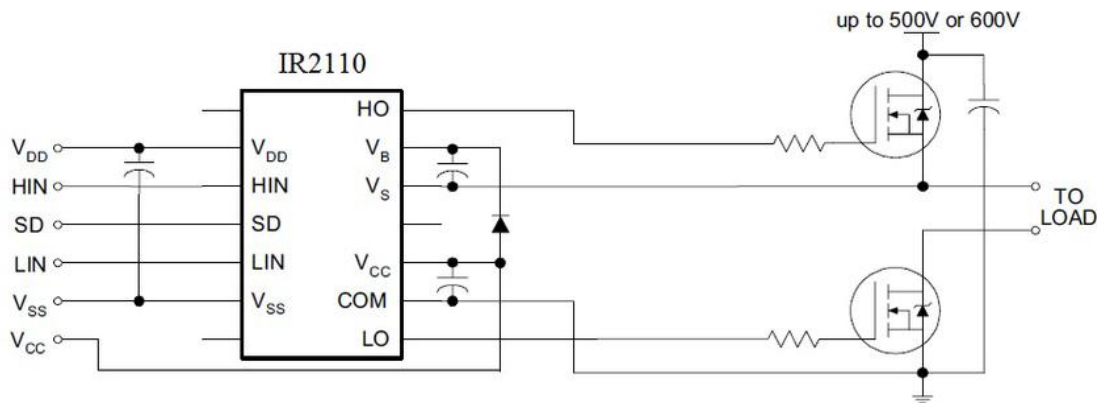

Figure 3.5: Typical Connection for IRFB4110Pbf MOSFET Driver

### 3.2.1.4 Feedback for Voltage Control

As the battery voltage begins to deplete during normal usage, the output voltage from the inverter will also deplete respectively. To ensure the inverter output remains constant throughout the normal operation of the inverter, a 15V feedback voltage is sent back from the transformer to the microcontroller so that the controller can compensate for the gradual drop in the battery voltage during the normal operating period of the inverter.

Feedback voltage turns ( $T_{FB}$ ) is calculated as:

$$T_{FB} = (15V \times 230V)/600 = 6 \text{ turns} \dots \dots \dots (3.14)$$

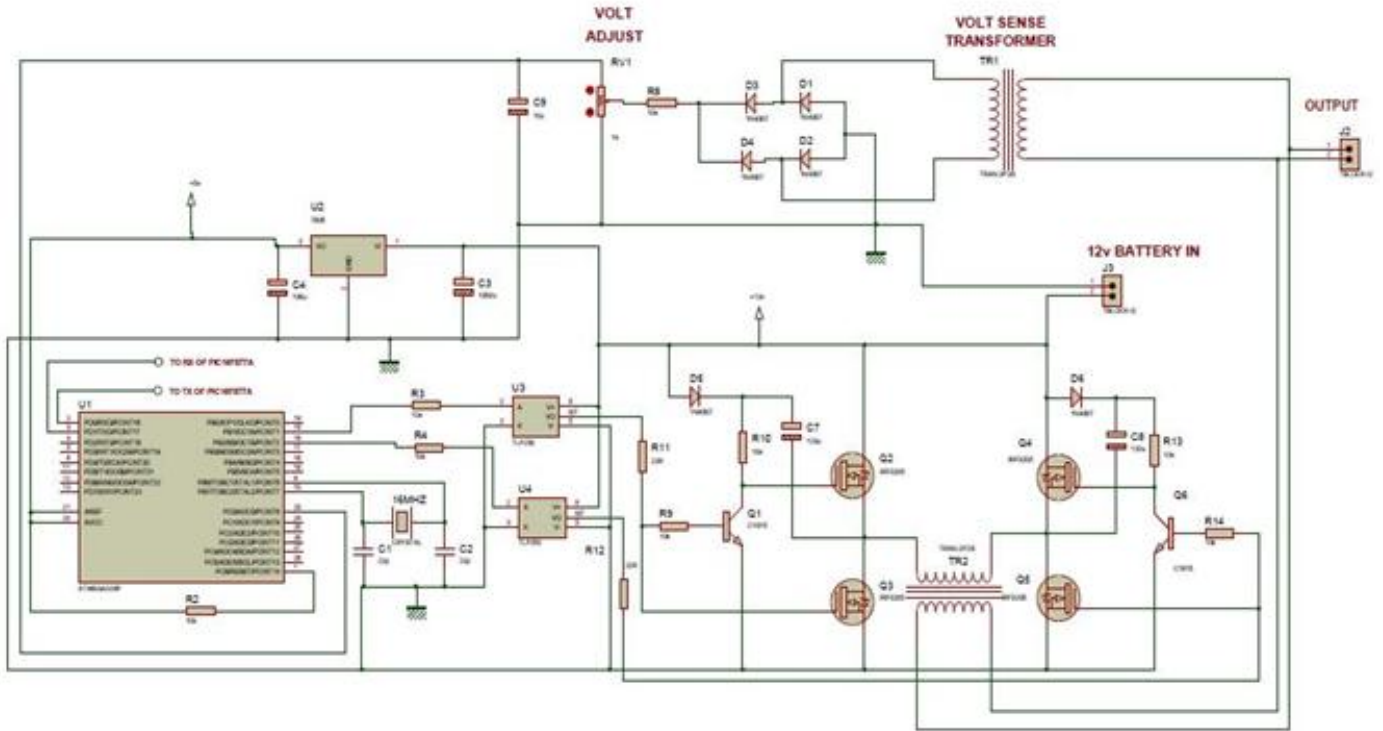

Figure 3.6: Inverter Circuit Diagram

### 3.2.2 Ac Mains Block

This block describes the AC supply input from the distribution source, in this case a generator. A generator is a mechanical device that converts mechanical energy into electrical energy. The electricity generated at various power plants is produced by the generators installed there. When a coil spins in a magnetic field or moves relative to a magnet, it generates an electromotive force (emf) or potential difference. The generator needed for this practical is rated 230V at 50Hz frequency. It is assumed to be at infinite power rating.

### 3.2.3 Synchronous Block

This block could be referred to as the brain of the system. The Synchroscope block links the power sources from the inverter and generator and helps in stabilization to produce a suitable output necessary to make the load function. A circuit breaker acts as the synchronizer, a three way switch to change the oscilloscope display from generator to inverter as we are only using one oscilloscope in

this project. The oscilloscope helps to display the waveform of the inverter and the generator. The Oscilloscope has a probe connected to a step down transformer, that steps down the voltage from 220v to 12v, this 12v is further stepped down by a voltage divider that reduces it to 5v.

### 3.2.4 Display Block

A liquid-crystal display (LCD) is a flat-panel display or other electronically modulated optical device that uses the light-modulating properties of liquid crystals combined with polarizers. Liquid crystals do not emit light directly but instead use a backlight or reflector to produce images in colour or monochrome. LCDs are available to display arbitrary images (as in a general-purpose computer display) or fixed images with low information content, The LCD screen is used to display the status of the battery's state of charge, the inverter and mains voltage values and frequency.

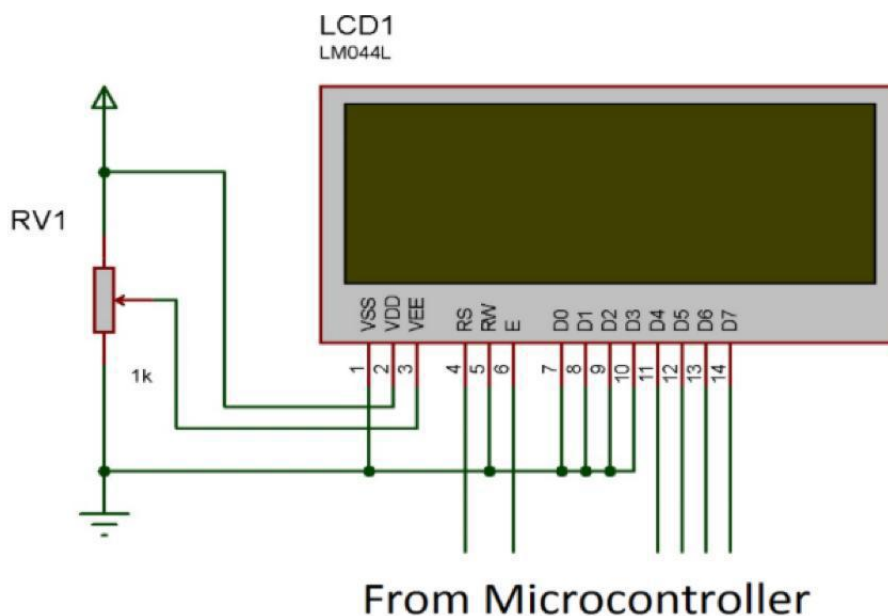

Figure 3.7: LCD circuit diagram

### 3.2.5 Relay Block

Relays are electromechanical devices that use an electromagnet to operate a pair of movable contacts from an open position to a closed position. The advantage of a relay is that it takes a relatively small amount of power to operate the relay coil. However a relay switch circuit can be used to control motors, heaters lamps or AC circuits which themselves can draw a lot more electrical voltage, current and therefore power. The electro- mechanical relay is an output device (actuator) which comes in a whole host of shapes, sizes and designs, and has many uses and applications in electronic

circuits. The block below comprises transistors, relays, a 30A relay and its accompanying circuitry which enables the master microcontroller to effectively control the synchronization process and cut off either the inverter or AC Mains supply from the load output whenever it is necessary. When the switch at the relay block is in our synchronizing circuit which when turned on draws voltage from both the generator and current.

$$V_{in} = 220V$$

$$\text{Power} = 2KVA = 2000VA$$

$$P = IV$$

$$\text{Hence } I = P/V$$

$$I = 2000/220 = 9.09A$$

Hence, we use the JQC-3FF relay, as it meets all our criteria.

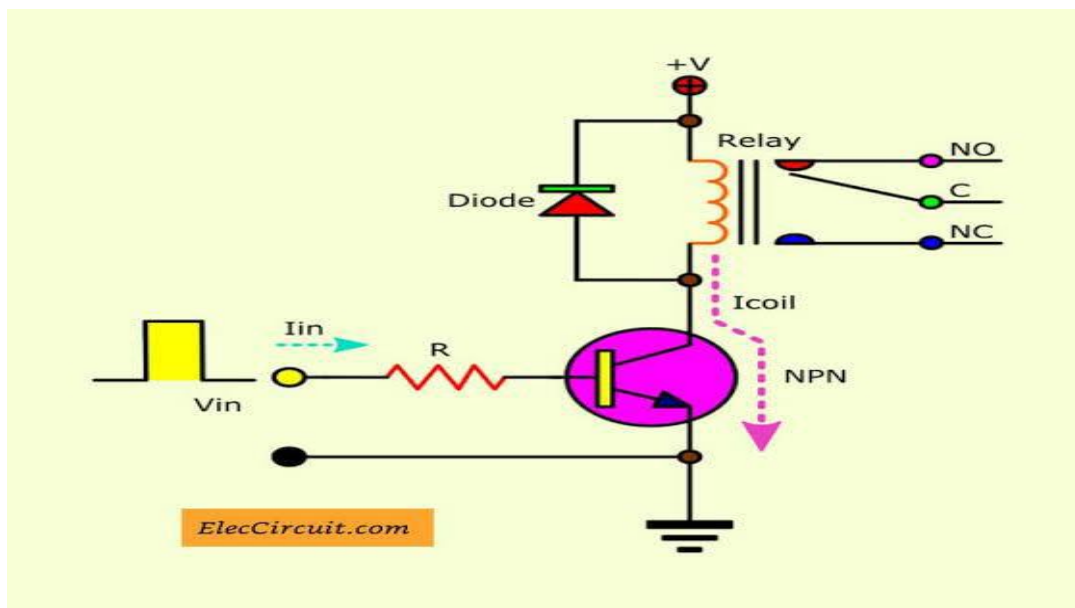

Figure 3.8: Transistor and Relay Circuit Diagram

### 3.2.6 Current Booster Block

The current booster plays a crucial role in optimizing the voltage output obtained from the synchronization system. Initially, the output voltage from this system ranged from approximately 350 to 400 volts, which presented certain operational challenges. However, with the incorporation of the current booster into the system, this voltage variance is effectively mitigated, resulting in a

consistent and stable output voltage of 220 volts.

This voltage stabilization is not the only benefit offered by the current booster; it also enhances the current capacity of the system. By doing so, it ensures that the load receives a reliable and constant supply of current. Furthermore, the current booster operates in a balanced manner, drawing an equal amount of current from both the inverter and the generator. This equilibrium ensures efficient and synchronized operation of these power sources, contributing to the overall stability and reliability of the electrical system.

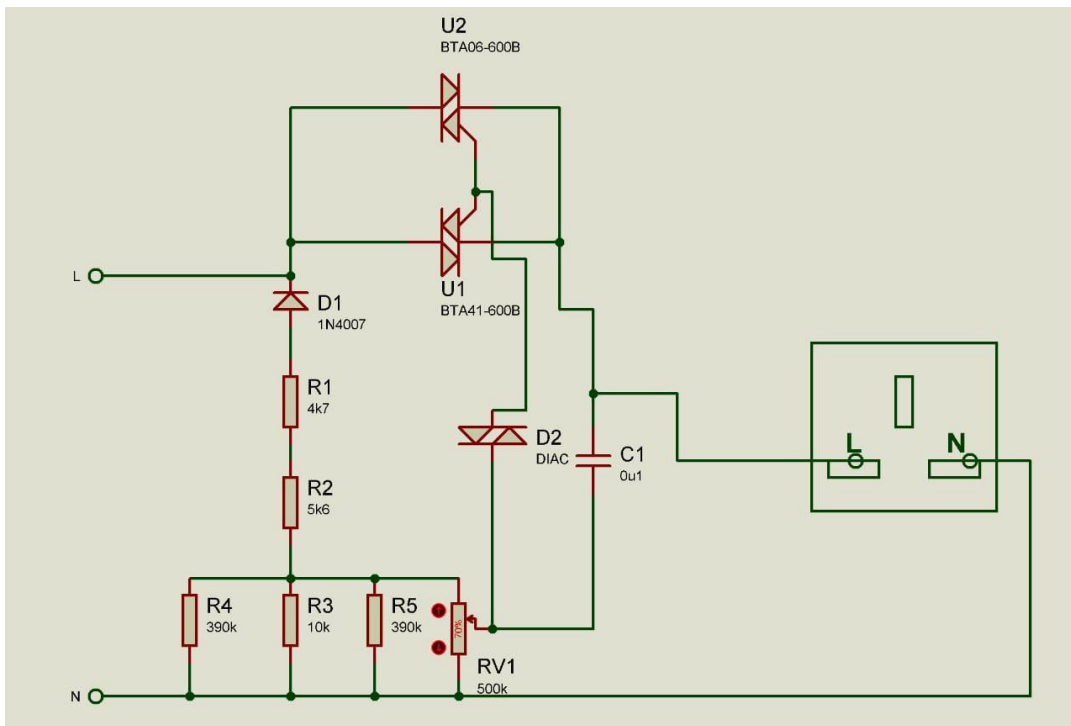

Figure 3.9: Current Booster

### 3.2.7 Load Output Block

This block describes a terminal outlet where the synchronized power can be accessed by a user. A 13 amps socket is connected from the relays.

### 3.3 Synchroscope Circuit Diagram

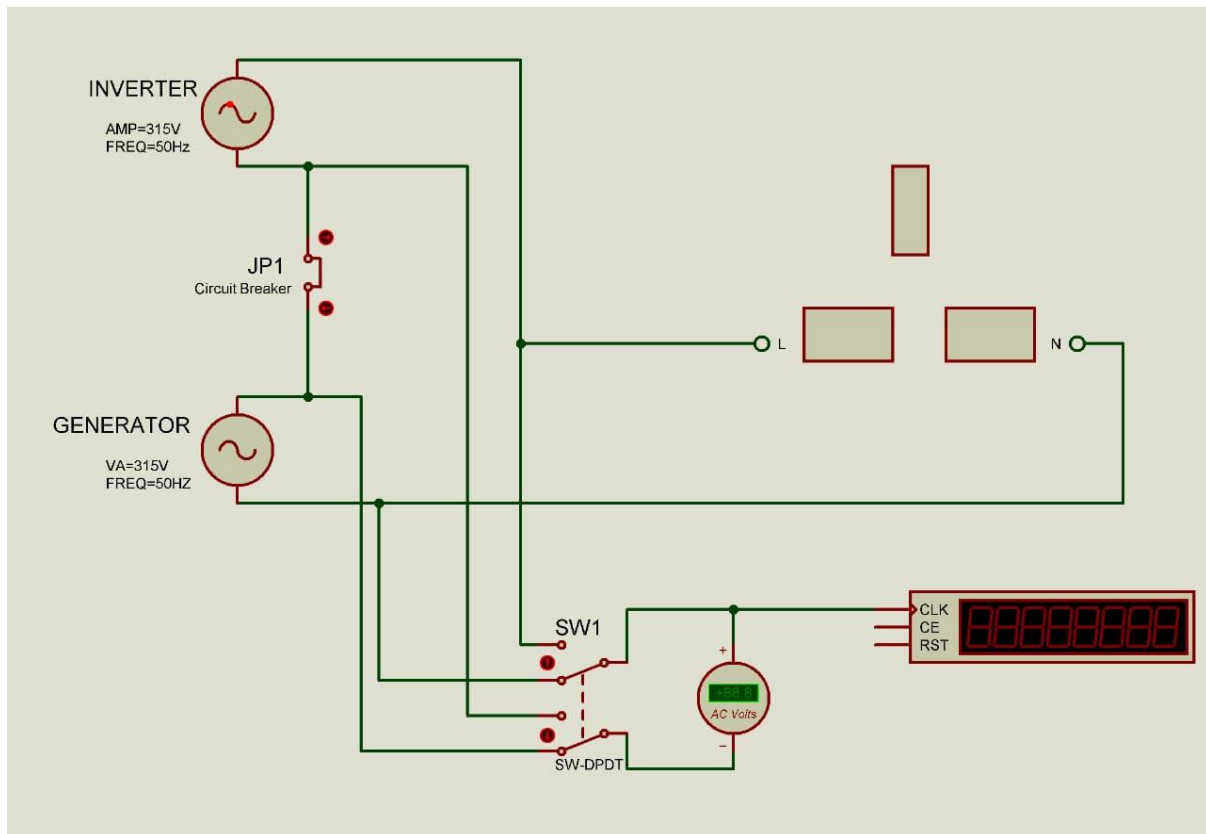

Figure 3.10: Synchroscope Circuit Diagram

### 3.4 Principle of Operation

Manual synchronization between an inverter and a generator involves aligning their frequency, phase, and voltage levels to safely connect them in parallel. This process utilizes an oscilloscope and a circuit breaker as a synchronizer. The basic principle of operation is as follows:

Set up both the inverter and generator, ensuring they are operational and generating power.

Connect the oscilloscope probes to measure voltage signals from both devices and display the waveforms on the oscilloscope screen.

Observe the waveforms and gradually adjust the frequency of either the inverter or the generator using their respective controls until the waveforms appear stationary or nearly so.

Next, adjust the output voltage of either the inverter or the generator until the waveforms align and overlay each other on the oscilloscope screen.

Once the frequency and voltage are matched, close the circuit breaker to connect the inverter and the generator in parallel.

Continuously monitor the voltage and frequency levels on the oscilloscope to ensure that the inverter and the generator remain synchronized.

If any deviation is noticed, promptly open the circuit breaker to avoid potential damage or accidents.

## CHAPTER FOUR

### CONSTRUCTION TESTING AND RESULT ANALYSIS

#### 4.1 Construction

To demonstrate the effectiveness of this synchroscope system, a prototype of the device is constructed. The steps in the development of this prototype system are as follows:

- Simulation of the Design
- Acquisition of Required Materials
- Sorting of Tools
- Printed Circuit Board Design
- Soldering and connection of electronic components and modules to make up the designed system.
- Microcontroller Programming
- Packaging
- Testing

#### 4.2 Simulation

The desired physical or mental framework or process must first be modelled in terms of its fundamental characteristics, functions, and components. The framework's behaviour over time is described by the model.

The Proteus 8 professional simulator system was used to replicate the synchroscope prototype system. A reasonable recreation programmer for varied designs with a microcontroller is the Proteus 8 professional simulator system. Due to the accessibility of every microcontroller in it, it is widely used. It is a handy tool for testing installed hardware designs and software applications.

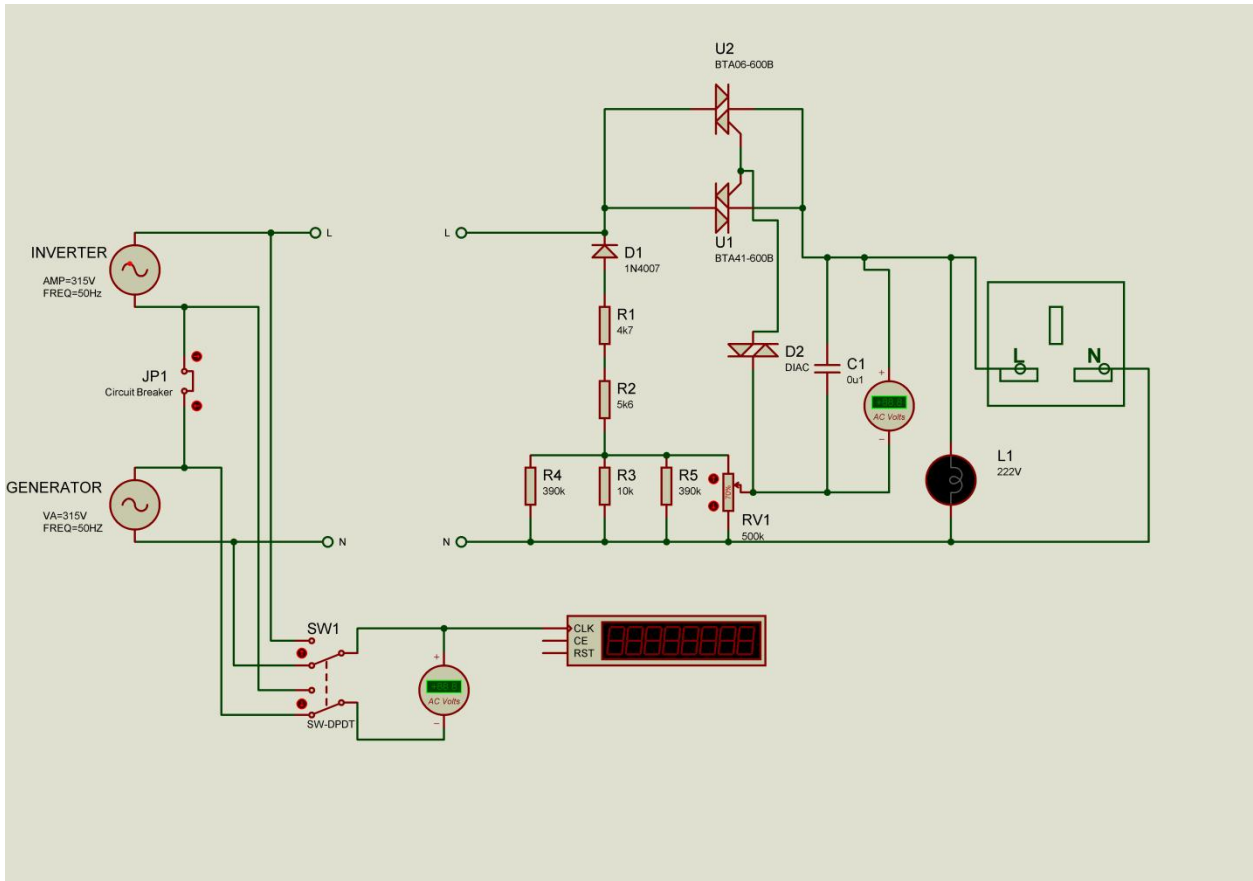

Figure 4.1: Simulation of synchronizing circuit

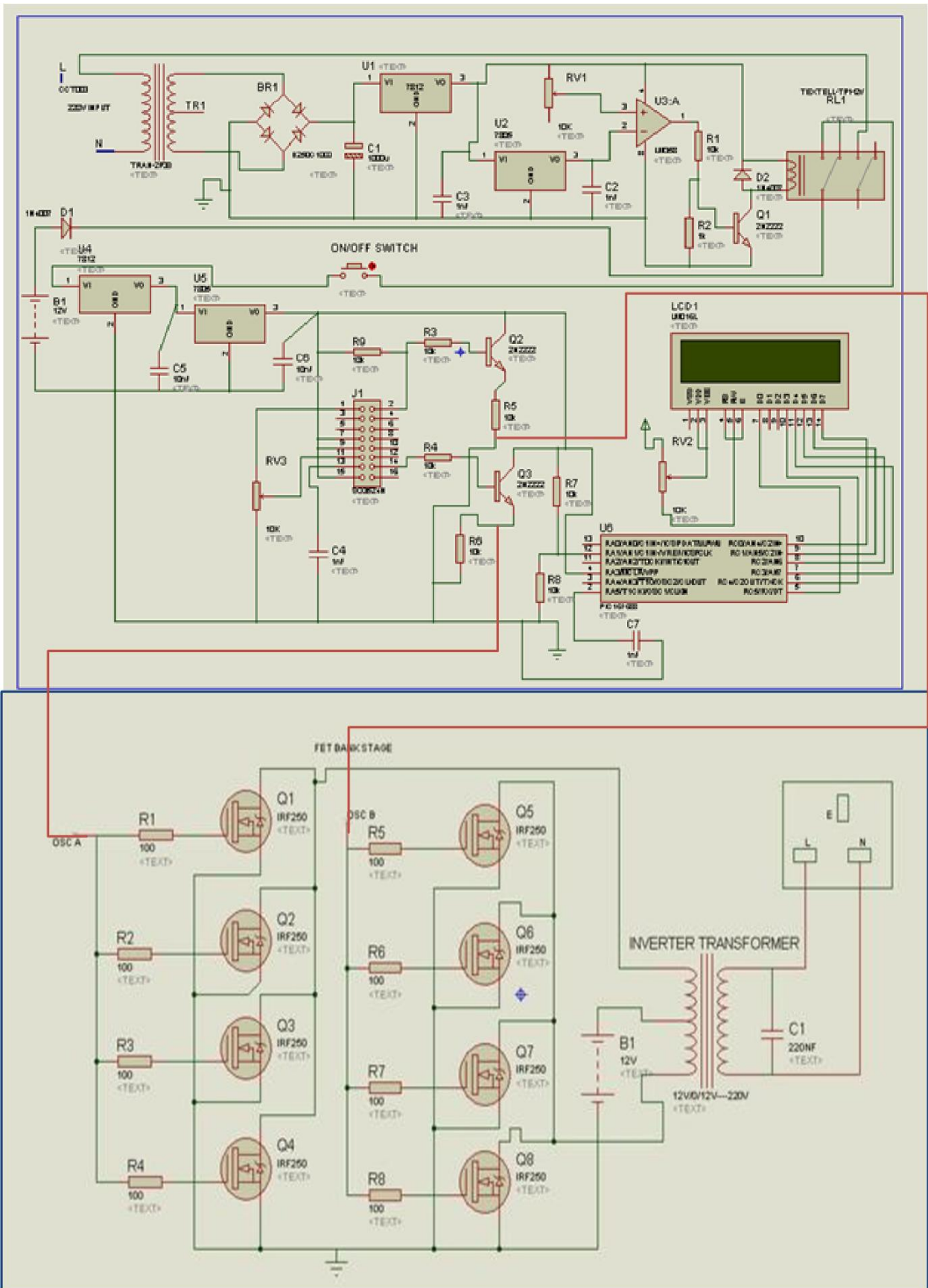

Figure 4.2: Simulation of inverter circuit

### **4.3 Acquisition of Components**

Some of the electronic parts were bought in local markets, while others were bought online through sites like Hub360, Jumia, Alibaba, Amazon, and many other internet marketplaces. The parts used in this project were obtained from a nearby Onitsha electronics store and through this website ([www.hub360.com.ng](http://www.hub360.com.ng)).

### **4.4 Printed Circuit Board Design**

ARES (Advanced Routing and Editing Software) is used for PCB design. ARES (Advanced Routing and Editing Software), a PCB layout module in the Proteus Design Suite, offers a complete set of high-performance design automation tools for net-list-based PCB design.

#### **4.4.1 ARES Layout Editor Features**

Major features of ARES Professional include:

- 32bit high-precision database giving a linear resolution of 10nm, an angular resolution of 0.1° and a maximum board size of +/- 10m. ARES supports 16 copper layers, two silkscreens, four mechanical layers plus solders resist and paste mask layers.
- Hardware accelerated display (Direct 2D or OpenGL) using the power of your graphics to improve speed and provide true layer transparency.
- State of the art ergonomic user interfaces with model selection, selection and activity indicators and localized functionality via context menus.
- Live net-list and shared database binding with the ISIS schematic capture module, including the ability to specify routing information on the schematic.





Figure 4.4: Soldering and build-up

## 4.6 Microcontroller Programming

Transferring a written program from the microcontroller's compiler memory is referred to as programming or burning a microcontroller.

### 4.6.1 Compiler

A tool called a compiler can be used to create, test, and investigate a microcontroller program. The compiler converts the machine language instructions into a Hex document that a microcontroller can comprehend. A microcontroller will operate exactly as set out in the program.

In this project, a C program is written using the mikroC for PIC, which is also used to translate the written program into machine language and store it in a Hex file.

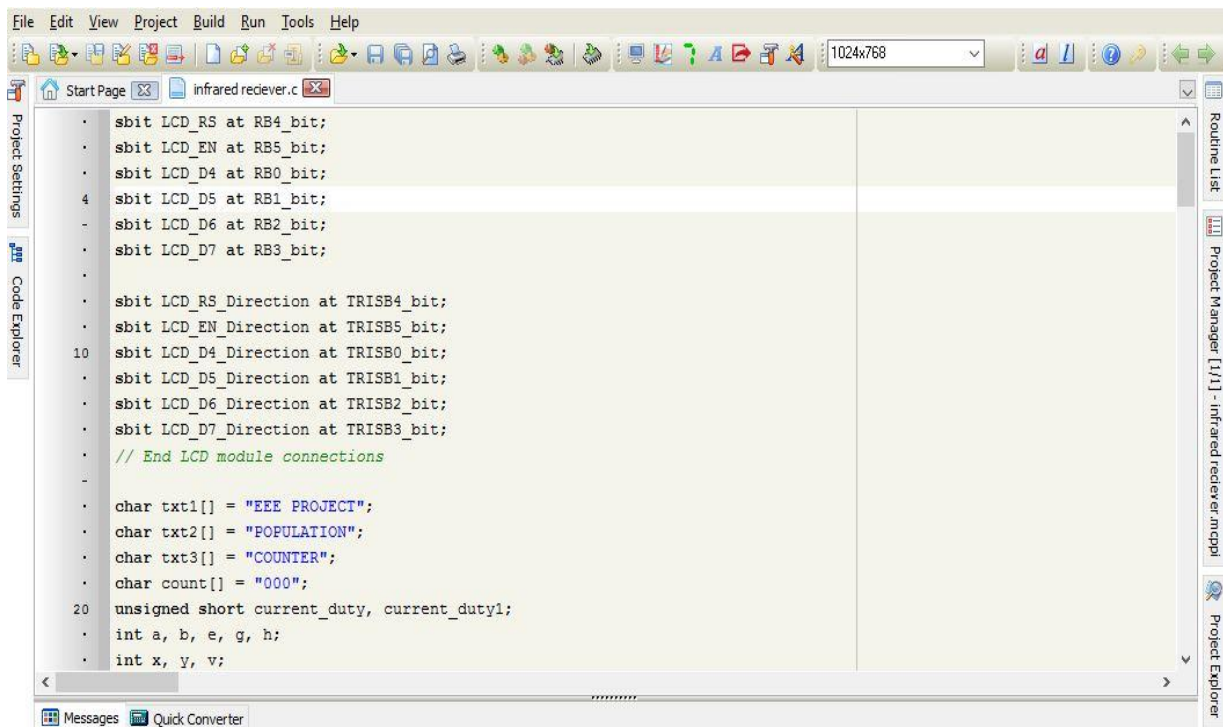

Figure 4.5: Microcontroller Programming

#### 4.6.2 Programmer

This project's goal is to teach you how to program a microcontroller using a tool called a programmer/burner. When a hex file is saved on a computer or mobile device, a programmer is a piece of hardware with its own proprietary software that can read the contents and send the data to a microcontroller. It can read a hex file's contents and transfer them to the micro-controller's RAM when linked to a computer through serial or USB. There, they can be modified in accordance with the manufacturer's recommended coding standards.

The heap robotization and control unit was programmed using a PICKit2 enhancement programmer. The PICKit2 improvement Programmer is an easy-to-use development tool for examining and programming Microchips line of micro-controllers and serial EEPROM devices. The PICKit2 programmer is connected to the programmer's PC via the USB connection, and in order to enable communication with the equipment device, the programmer must have installed the necessary software and drivers. Five pins are used on the PICKit2 programmer's other interface to connect to and communicate with the microcontroller device; they are

- $V_{pp}/MCLR$ .
- $V_{dd}$  target.
- $V_{ss}$ (ground).

- ICSPDAT/PGD.
- ICSPCLK/PGC.

### 4.7 Packaging

The desired outlook of this prototype was drawn using Microsoft Paint tool. This outlook as shown below shows an estimated dimension of the size of the dustbin used in packaging this prototype.

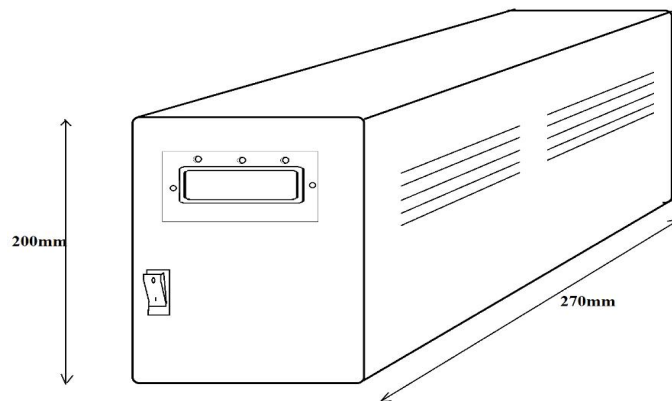

Figure 4.6: Proposed Packaging

The implemented packaging for the completed project prototype is shown below.

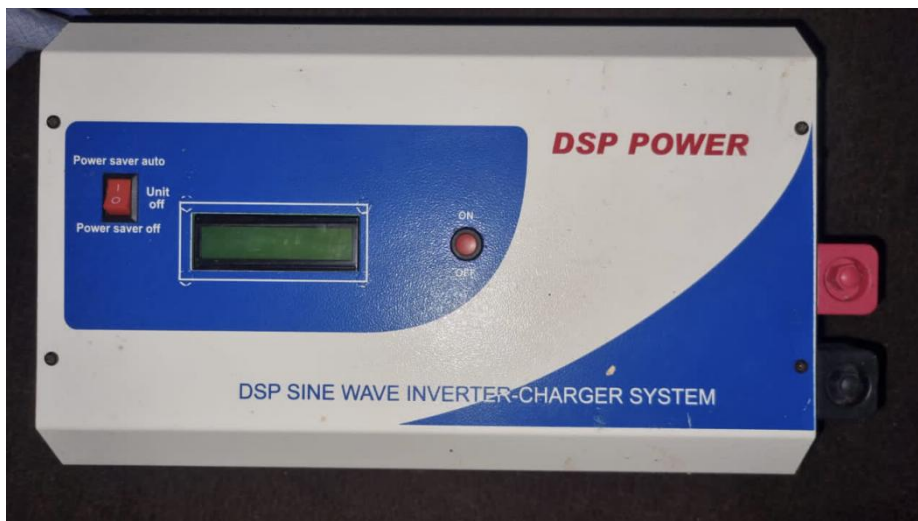



Figure 4.7: Views of the inverter

#### 4.8 Step by Step Design Procedure

Step by step design procedures leading to the finish work are as follows

1. computer programming for micro-controllers.
2. PCB fabrication (which includes printing on glossy paper, ironing, and etching)
3. the PCB's holes being drilled.
4. Major components, such as MOSFETs, diodes, and resistance, are tested to look for variations from declared values.
5. soldering after component insertion into the PCB.
6. Transformers, contactors, and other large loads should not be mounted on the PCB.

7. joining and connecting the two boards.
8. One more test to ensure correct continuity and adequate insulation if necessary.
9. testing the apparatus
10. modifying potentiometers to produce the necessary readings
11. Additional Coupling Testing

## 4.9 Testing and Result Analysis

After the prototype was built, the system was tested and run under two load scenarios: when the load was less than 1 kVA and when the load was 2 kVA. For testing, a non-inductive load was utilized.

### 4.9.1 Test condition one (Load Current Less Than 5A)

Under this condition, it was observed that the inverter and generator was running smoothly.



Figure 4.8: Test Condition One

### 4.9.2 Test condition two (Load Current Exceeds 5A)

With the presence of the AC mains supply the synchronizing process kick started as soon as the load exceeded 5A. After a few seconds the synchronization was completed with variable manual synchronization attempts until a desired outcome was achieved

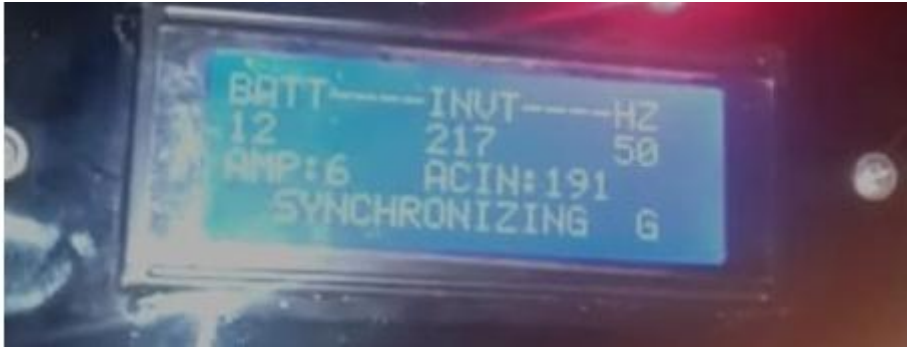

Figure 4.9: Test condition Two



Figure 4.10: Synchronization Complete

## 4.10 Bill Of Engineering Measurements And Evaluation (BEME) As AT September, 2023

Table 4.1 Bill Of Engineering Measurements And Evaluation.

S/N	Items Required	Description	Amount Required	Unit	Price Per Unit (N)	Price (N)
1.	2500VA Transformer	12v/220v	1	Piece	45,000	45,000
2.	Battery 200Ah	Quanta Deep Cycle (Wet cell)	2	Pieces	200,000	400,000
3.	4uf Capacitor	Charge accumulator	3	Pieces	1000	3000
4.	TLP 250 MOSFET Drivers	MOSFET Drivers	4	Pieces	4000	16000
5.	IRF3205 MOSFET	High Power Transistors	16	Pieces	1200	19200
6.	Heat Sink	Aluminum	4	Pieces	5000	20,000
7.	Printed Circuit Board	Copper Cladded board for MOSFET, microcontroller and sine oscillator circuits	2	Pieces	3000	6000
8.	LCD Display	16 X 4 Characters	1	Piece	3500	3500
9.	Capacitors	22pF, 10mF, 1000uF, 0.01uF, 47uF,	20	Pieces	100	2000
10.	Diluted H <sub>2</sub> SO <sub>4</sub> and H <sub>2</sub> O <sub>2</sub>	Etching	1	Liters	7000	7000
11.	Resistor	10kOhm, 10Ohm, 4.7Ohm, 5.6kOhm, 1kOhm, 2.2KOhm, 2KOhm.	20	Piece	50	1000
12.	1n4001 Diodes	PN diode	10	Pieces	50	500
13.	1n4148 Diode	Zener Diodes	20	Pieces	30	600

Table 4.1 Bill Of Engineering Measurements And Evaluation.

S/N	Items Required	Description	Amount Required	Unit	Price Per Unit (N)	Price (N)
14.	Relays	10A, 30A, 12V relay	5	Pieces	500	2500
15.	16mm <sup>2</sup> Copper Cable	Positive and Negative Battery Connector Cables	2	Yards	500	1000
16.	Terminals and Plugs	Battery Logs, 2 pin connectors, 8 pin connectors.	1	Lot	-	5000
17.	C1815	NPN Amplification Transistor	2	Pieces	250	500
18.	Cooling Fan	12V Cooling Fan	1	Piece	300	300
19.	IC Socket	28 and 40 pins IC socket	2	Pieces	50	100
20.	Jumpers and inter connecting wires	Twisted pair jumper cable	5	Yards	200	1000
21.	Line connectors	8 in 1 line connector, 2 in one line connector	5	Pieces	200	1000
22.	Dsp30f2010	MCU type	1	Pieces	7500	7500
23.	Triac	3-Electrode AC Switch	2	Piece	750	1500
24.	12V AC to DC module	SMPS rectifier Module.	1	Pieces	1500	1500
25.	Casing	Plastic Box Casing with metal framework	1	Pieces	40,000	40,000
26.	13 Amp Plug	Load separation adapter plug	4	Pieces	500	2000
27.	13Amp Socket	Load Separation adapter socket	4	Pieces	500	2000

Table 4.1 Bill Of Engineering Measurements And Evaluation.

S/N	Items Required	Description	Amount Required	Unit	Price Per Unit (N)	Price (N)
28.	Extension	13 Amp input	1	Piece	2500	2500
29.	Screws	1 inch	1	Packet	500	500
30.	Wall mount Board	6 x 10 inches	2	Board	500	1000
31.	Adaptable box	Plastic box	2	Piece	4,000	8,000
32.	Oscilloscope	Display and analyzer of Electrical signal	1	Piece	45,000	45,000
33.	Circuit breaker	Electrical switch	4	Pieces	1,000	4,000
34.	<b>CostOf Materials</b>	-	-	-	-	<b>650,700</b>
35.	Logistics And Shipping Of Materials	-	-	-	-	40000
36.	<b>GROSS TOTAL</b>	-	-	-	-	<b>690,700</b>

Summary as follows;

Cost of Materials ..... **650,700**

Gross Total ..... **690,700**

Approx. **N700,000**

## CHAPTER FIVE

### CONCLUSION AND RECOMMENDATION

#### 5.1 Conclusion

In conclusion, the project on the design and construction of a prototype synchronizing system using a generator and inverter has been a significant endeavour that has yielded valuable insights and practical applications. Throughout this project, we have achieved several key milestones and learned important lessons that contribute to the advancement of power generation and synchronization technology.

Our work began with a thorough understanding of the theoretical principles behind synchronization, generators, and inverters. We then applied this knowledge to design a prototype system that effectively synchronizes a generator with an inverter-based power source. The construction phase involved meticulous attention to detail, precision engineering, and rigorous testing to ensure the system's reliability and efficiency.

One of the major accomplishments of this project is the successful synchronization of the generator and inverter, which allows for seamless power transfer and load-sharing between these sources. This achievement has implications not only for off-grid power systems but also for various applications in renewable energy integration, backup power, and microgrid development.

Furthermore, the project has highlighted the importance of synchronization in maintaining power quality and grid stability. The ability to synchronize different power sources effectively can enhance the resilience of electrical grids and promote the integration of renewable energy sources, ultimately contributing to a more sustainable and reliable power supply.

While this prototype system represents a significant step forward, there is still room for improvement and further research. Future work in this area could explore advanced control algorithms, real-time monitoring and feedback systems, and scalability to accommodate larger power systems.

In conclusion, the design and construction of our prototype synchronizing system have provided valuable insights and practical solutions for addressing the challenges of power synchronization. This project underscores the importance of innovative engineering in advancing the field of power generation and distribution. As we move forward, the knowledge and experience gained from this

project will continue to drive progress in the quest for more efficient, reliable, and sustainable power systems.

## **5.2 Limitations Of The Work**

In designing a synchroscope prototype, the following constraints were encountered

1. Building a prototype synchronizing system can be cost-intensive, and the components used in the project may not be representative of what would be used in a commercial or large-scale implementation. Cost-effectiveness could be a significant concern for practical applications.
2. Due to the fact that the device used in this work is a prototype, its capacity was limited as it could only synchronize between an inverter and a single phase AC mains/generator source. It was not possible to utilize two generators
3. The prototype system may not be compatible with all types of generators and inverters available in the market. Compatibility issues can be a significant limitation when attempting to integrate different brands or technologies
4. The accuracy of synchronization achieved by the prototype may not meet the stringent requirements of certain critical applications, such as hospitals or data centres, where even slight deviations in voltage and frequency can be detrimental.

## **5.3 Recommendations**

After completion of the project work, it is relevant to proffer the following recommendations which are necessary to achieve a more efficient AC synchronizing system:

1. Continue to refine and optimize the synchronization system's performance. Explore different control algorithms and tuning parameters to achieve even greater accuracy and responsiveness in synchronization.
2. Consider implementing remote monitoring and control capabilities for the synchronization system. This would allow for real-time monitoring and adjustments, improving system management and reducing the need for on-site presence

3. Conduct a detailed cost analysis to determine the feasibility of the prototype system for commercial or industrial applications. Explore ways to reduce production costs without compromising performance.
4. Investigate how the prototype system can be integrated with renewable energy sources, such as solar panels and wind turbines, to promote sustainable power generation and reduce reliance on fossil fuels.

## REFERENCES

1. Afzal H.M., Khan W.Z, Rehman M.H, Zangoti M.K, Armi N, Salah K, 2020 Industrial internet of things: Recent advances, enabling technologies and open challenges. Computer and Electronics. Eng., 81, 106522.
2. Anderson L. S., Gross L. C., and Young R. C, 2021 Avoid Generator and System Damage Due to a Slow Synchronizing Breaker, proceedings of the 24th Annual Western Protective Relay Conference, Spokane, WA, Technology (ICCICT), Mumbai, India, 2527; pp. 15.
3. Australian Renewable Energy Agency (ARENA), 2023, Repurposing Existing Generators As Synchronous Condenser, 3971-ETR-01.
4. Avinash K.S, 2019, Introduction To Power System Analysis
5. Balbin, J.R.; Chua, E.E.; de Leon, J.P.C.; Dolor, J.H.R.D., Sese, R.L.A. Cloud-Based Remote Monitoring System for Photovoltaic Systems with Electrical Load Prioritization. Proceedings of the 2020 IEEE 12th International Conference on Humanoid, Nanotechnology, Information Technology, Communication and Control, Environment, and Management (HNICEM), Manila, Philippines, 37; pp. 16.
6. Edvard C, 2023, The Art Of Generator Synchronization Techniques That Every True Engineer Must Know About
7. IEEE Guide for AC Generator Protection, IEEE Standard C37.102-2006.
8. IEEE Guide for Operation and Maintenance of Turbine Generators, IEEE Standard 67-2005.
9. IEEE Standard for 50Hz and 60Hz Synchronous Generators for Non-Hydraulic Applications Rated 10 MVA and Above, IEEE Standard C50.13-2014.
10. Linquip Team. 2022 Synchronization Of Generators: Step To Step Guide.
11. Rodriguez F., Victor H.P., Javier G., Jorge H.A., 2023. Synchronization and Optimal Operation of a 140kva Inverter in On-Grid Mode Using Mamdani Controllers in Cascade
12. Theraja B.L. and Theraja A.K, A TextBook Of Electrical Technology