

DESIGN AND CONSTRUCTION OF A WIRELESS CHARGER

BY

OKAFOR IFECHUKWUDE HENRY

ENG1604179

DEPARTMENT OF ELECTRICAL/ELECTRONICS ENGINEERING

FACULTY OF ENGINEERING

UNIVERSITY OF BENIN

BENIN CITY

JULY 2021

DESIGN AND CONSTRUCTION OF A WIRELESS CHARGER

BY

OKAFOR IFECHUKWUDE HENRY

ENG1604179

A PROJECT WORK SUBMITTED TO THE DEPARTMENT OF  
ELECTRICAL/ELECTRONICS ENGINEERING, FACULTY OF ENGINEERING IN PARTIAL  
FULFILMENT OF THE REQUIREMENT FOR THE AWARD OF BACHELOR OF  
ENGINEERING (B.ENG.) DEGREE IN ELECTRICAL/ELECTRONICS ENGINEERING.

JULY, 2021.

**CERTIFICATION**

This is to certify that this project was undertaken in accordance with the regulations and requirement of the Department of Electrical/Electronics Engineering, University of Benin, Benin City, by

OKAFOR IFECHUKWUDE HENRY, ENG1604179

-----

Engr.(Mrs)Omoze

Project Supervisor

-----

DATE

-----

Engr.Prof(Mrs)P.E.Orukpe

Head of Department

-----

DATE

## **DEDICATION**

This work is dedicated to Jehovah Almighty God for His love, mercy and goodness in our lives and for giving me strength to carry out this work.

## **ACKNOWLEDGEMENT**

We give God all the glory, the most compassionate and the most merciful for giving us the strength and opportunity to finish this project. We like to also express gratitude towards our supervisor, Engr. Mrs Omoze for giving us the guidance, support and ideas in completing this project. Finally, we are also using this opportunity to acknowledge and thank our parents, our elderly once who in one way or the other has helped .

## ABSTRACT

In this paper, a wireless power transmission (WPT) using resonant magnetic coupling for mobile phone charger is presented. Solar energy was used as the energy source to address the scarcity of non-renewable energy sources and tackles the constraints of wired charging technology such as lack of universal electrical standard, untidiness and inconvenience of wires and wires' wear and tear. The system includes PV panels and battery, oscillator, transmitting coil and receiving coil and rectifier. Proteus 8.1 was used to simulate before implementing in the hardware. The resonant magnetic coupling resonated at  $800 \text{ kHz} \pm 10 \text{ kHz}$ . The maximum distance to charge a mobile phone was 4 cm at 3.7 V. All the objectives are achieved within the limited time frame. The significance of the project can help to eradicate the use of wires and the need of power plugs. The future research includes the study of efficiency, coil design, system with multiple loads.

## TABLE OF CONTENTS

### Table of Contents

CERTIFICATION .....	iii
DEDICATION .....	iv
ACKNOWLEDGEMENT .....	v
ABSTRACT .....	vi
TABLE OF CONTENTS .....	vii
LIST OF FIGURES .....	ix
CHAPTER 1 .....	1
INTRODUCTION .....	1
1.1 INTRODUCTION .....	1
1.2 OBJECTIVE OF THE PROJECT .....	3
1.3 SIGNIFICANCE OF THE PROJECT .....	4
1.4 LIMITATION OF THE PROJECT .....	4
1.5 APPLICATIONS OF THE PROJECT .....	5
1.6 SCOPE OF THE PROJECT .....	5
1.7 Thesis Outline .....	6
CHAPTER 2 .....	7
LITERATURE REVIEWS .....	7
2.1 Introduction .....	7
2.2 History of Wireless Power Transmission .....	7
2.3 Basic Principles of Wireless Power Transfer .....	14
2.4 Justification for the Study .....	15
2.5 Main concepts of wireless transmission of electric energy .....	15
2.6 Wireless transfer by Inductive Coupling .....	18
2.8 Disadvantages of wireless Charger .....	24
2.9 Summary of the chapter .....	24
CHAPTER 3 .....	26

DESIGN AND METHODOLOGY .....	26
3.1 Introduction .....	26
3.2 DC power source .....	26
3.3 Basic Configuration of a Buck Converter .....	27
3.3.1 Necessary Parameters of the Power Stage .....	27
3.3.2 Calculate the Maximum Switch Current .....	27
3.3.3 Inductor Selection .....	29
3.3.4 Rectifier Diode Selection .....	30
3.3.5 Output Voltage Setting .....	31
3.3.6 Input Capacitor Selection .....	32
3.3.7 Output Capacitor Selection .....	32
3.4. Principle of operation .....	34
Working of transmitter circuit .....	36
DC Supply .....	36
Transmitter coil .....	36
Working of reciever circuit .....	36
Receiver Coil .....	37
3.5 Components .....	37
3.6 Summary .....	38
<b>CHAPTER 4 .....</b>	<b>39</b>
RESULTS AND DISCUSSIONS .....	39
4.1 Results .....	39
4.2 Analysis and Discussion .....	39
4.3 Summary .....	41
<b>CHAPTER 5 .....</b>	<b>43</b>
CONCLUSION AND RECOMMENDATION .....	43
5.1 Conclusion .....	43
5.2 Recommendations .....	43
REFERENCES .....	44

**LIST OF FIGURES**

Figure 2. 1 ..... 11  
Figure 2. 2 ..... 14  
Figure 2. 3 ..... 16  
Figure 2. 4 ..... 17  
Figure 2. 5 ..... 18  
Figure 2. 6 ..... 20  
Figure 2. 7 ..... 20  
Figure 2. 8 ..... 22

Figure 3. 1 ..... 26  
Figure 3. 2 ..... 34  
Figure 3. 3 ..... **Error! Bookmark not defined.**  
Figure 3. 4 ..... **Error! Bookmark not defined.**  
Figure 3. 5 ..... **Error! Bookmark not defined.**  
Figure 3. 6 ..... **Error! Bookmark not defined.**

## CHAPTER 1

### INTRODUCTION

#### 1.1 INTRODUCTION

The method used in charging portable devices such as cellphone wirelessly is known as inductive charging. Inductive charging uses an electromagnetic field to transfer energy between two devices. This is usually done with a charging station. Energy is sent through an inductive coupling to an electrical device, which can then use that energy to charge batteries or run the device. Induction chargers use an induction coil to create an alternating electromagnetic field from within a charging base, and a second induction coil in the portable device takes power from the electromagnetic field and converts it back into electric current to charge the battery. The two induction coils in proximity combine to form an electrical transformer. Greater distances between sender and receiver coils can be achieved when the inductive charging system uses resonant inductive coupling. Recent improvements to this resonant system include using a movable transmission coil (i.e. mounted on an elevating platform or arm) and the use of other materials for the receiver coil made of silver plated copper or sometimes Aluminium to minimize weight and decrease resistance due to the skin effect.

Every day, new technologies make our life easier. Wireless charging via resonance can be one of the next technologies that bring in the next future. In this project, it is being shown that low-power devices can be wirelessly charged with inductive coupling. This reduces the complications arising from the use of conventional cable systems. In addition, the project also exposes the new possibilities of wireless systems in our daily life uses. We live in a world of technological advances new technology raises every day to make our life easier. In spite of this, we still rely on our everyday low power devices such as mobile phones, digital cameras, and even on mid-power devices like laptops, on the classical and conventional cable systems .The conventional cable system creates a mess when it comes to charging different devices simultaneously.

Wireless Power Transmission (WPT) is electric energy efficient transmission in the atmosphere without using one vacuum or cable or any other substance from one point to another. It can be used for applications where an instant amount or continuous supply of energy is required, but where conventional cables are unreasonable, inconvenient, expensive, dangerous, unwanted or impossible. Using inductive coupling for small range, power can be sent using resonant induction for high-range medium-range and electromagnetic wave power transfer. WPT is a technology that can transport electricity in places, which is otherwise not possible or is inadequate to reach. Mid Power Devices can be the next big thing by charging low power devices and ending intermittent connections. The purpose of this project is to design and form a method to transmit wireless electrical power through space and charge a designated low power device. The system will work using resonator coils to transmit a resisting load power from an AC line. Different geometric and physical structure factors are investigated to increase connectivity between transmitters and receivers. Being successful in this way will stop the use of chairs in charging process, so it is easy and easy to charge a low power device. It will also ensure the protection of the device as it eliminates the risk of short circuits.

Tresna Dewi et.al discussed the design and realization of a 12 V lamps, a cell-phone charger and a DC fan through the transmitter (source) powering multiple receivers (loads).

A. Gamini Sharma et.al introduce a new idea with the charging of cell phones wireless with the help of microwaves over a large scale. Micro-waves are the radio waves that are used to communicate through two mobile phones.

L. Olvitz et.al discussed that a wireless power transfer system is de-signed to get wireless power transmission to the mobile phone. Theory of the wire-less power transfer is explained and a functional wireless charger device is realized.

Xiao Lu et.al propose a novel concept of wireless charger networking that allows chargers to be connected to facilitate information collection and control.

Achmad Munir et.al proposed a technique that to get wireless power charging system for mobile device a technique is used based on magnetic resonance coupling. The generated AC signal to be transferred a transmitter circuit is used, to transfer the power of AC signal wirelessly transmitting and receiving radiators are used to convert AC signal to DC voltage a receiver circuit is used to convert the for charging the mobile device.

Khadijat Hassan et.al proposed a technique to change the mobile phone batteries through a multiple receiver wireless power transfer system. Transmitter and two receivers are connected to the system circuit. To understand its behavior, with the help of proposed concept a mathematical analysis of the circuit is carried out and simulated with variation in coupling coefficient and load.

Wenzheng Xu et.al discussed that travel distance of an electronic gadget mobile charger has minimized the sum of sensors lifetime get maximized when the use of a mobile charger to wirelessly charge sensors in a re-chargeable sensor.

Nathan S. Jeong et.al proposed a technique that a metal wrapped mobile device is enabled using loosely coupled resonant system obtain an efficient wireless charging. To simplify this approach, a metal phone case is used and three coils were designed and distributed on this metal phone case and they are tuned for resonance at 6.78MHz.

## **1.2 OBJECTIVE OF THE PROJECT**

The objective of this project is to design a wireless power transmission mobile charger circuit using inductive coupling is to charge a low power device using wireless power transmission. This is done using charging a resonant coil from AC and then transmitting subsequent power to the resistive load. The project is meant to charge a low power device quickly and efficiently by inductive coupling without the help of wires.

### 1.3 SIGNIFICANCE OF THE PROJECT

- Protected connections – No corrosion when the electronics are all enclosed, away from water or oxygen in the atmosphere. Less risk of electrical faults such as short circuit due to insulation failure, especially where connections are made or broken frequently.
- Low infection risk – For embedded medical devices, transmission of power via a magnetic field passing through the skin avoids the infection risks associated with wires penetrating the skin.
- Durability – Without the need to constantly plug and unplug the device, there is significantly less wear and tear on the socket of the device and the attaching cable.
- Increased convenience and aesthetic quality – No need for cables

### 1.4 LIMITATION OF THE PROJECT

- Slower charging – Due to the lower efficiency, devices take longer to charge when supplied power is the same amount.
- More expensive – Inductive charging also requires drive electronics and coils in both device and charger, increasing the complexity and cost of manufacturing.
- Inconvenience - When a mobile device is connected to a cable, it can be freely moved around and operated while charging. In most implementations of inductive charging, the mobile device must be left on a pad to charge, and thus can't be moved around or easily operated while charging.
- Incompatibility - Unlike (for example) a MicroUSB charging connector, there are no universal standards for inductive charging, thus necessitating various different chargers for different devices. Newer approaches reduce transfer losses through the use of ultra thin coils, higher frequencies, and optimized drive electronics. This results in more efficient and compact chargers and receivers, facilitating their integration into mobile devices or batteries with minimal changes required. These technologies provide charging times

comparable to wired approaches, and they are rapidly finding their way into mobile devices.

- Distance constraint: Field strengths have to be under safety levels
- Initial cost is high
- In RIC, tuning is difficult
- High frequency signals must be the supply Air ionization technique is not feasible

### **1.5 APPLICATIONS OF THE PROJECT**

1. Near-field energy transfer
2. Electric automobile charging Static and moving
3. Consumer electronics
4. Industrial purposes Harsh environment Far-field energy transfer
5. Solar Power Satellites
6. Energy to remote areas
7. Can broadcast energy

### **1.6 SCOPE OF THE PROJECT**

Wireless charger using inductive coupling, is one of the effective ways to transfer power between points without the use of conventional wire system. Wireless power transmission is effective in areas where wire system is unreachable or impossible. The power is transferred using inductive coupling, resonant induction or electromagnetic wave transmission depending on whether its short range, mid-range or high range.

In this project, the wireless charger works mainly on the principle of inductive coupling. With this inductive coupling idea, we are trying to transfer power wirelessly to charge low power devices, such as mobile phones, cameras, wireless mouse etc.

## 1.7 Thesis Outline

In this section, the outline of project report is presented. This report includes of six chapters and each chapter is explained.

Chapter 1: Discusses the introduction related to Wireless Power Transfer Systems, the background, significance, objective, limitation and problem of the study.

Chapter 2: Discusses the literature review on wireless power transfer systems, history of wireless power transfer and concept of wireless power transmission of electric energy.

Chapter 3: In this chapter the theory behind the design and construction of the project is given

Chapter 4: In this chapter, all testing that result accurate functionality was analyzed.

Chapter 5: This chapter gives the conclusion and recommendations after completion of the final year project. It covers assessment of whether project objectives and scope were achieved.

## CHAPTER 2

### LITERATURE REVIEWS

#### 2.1 Introduction

Wireless power transfer system has been tried several times throughout the last few centuries. The conception ideas started in the experiment of Henrik Hertz and Nikola Tesla in the 1890s and continued until this day. Although Nikola Tesla was confident about the idea of his transfer, and nobody was able to verify this idea. Nowadays, wireless power transfer is widely displayed through induction. Even though the wireless power transfer through induction limits a very small distance. This chapter provides a literary review of wireless power transfer history.

#### 2.2 History of Wireless Power Transmission

##### 2.2.1 19th century development and dead *end*

In the nineteenth century, many theories of theory were developed and counter theory about how to send electrical power. The circular law of Andrée-Marie Ampere in 1826 shows that electric current creates a magnetic field. In 1831, Michael Faraday described that electromotive power combines its induction with a time-changed magnetic flux to a conductor drive in a conductor loop. Without the wire, the transmission of electrical energy has been observed by many inventors and researchers, but lack of a coherent theory has suddenly led to the phenomenon of the electromagnetic index. A brief explanation of these events came from Maxwell's equation by James Clark Maxwell, 1860, which established the theory that electromagnetism combined the power and magnetism, which predicted the existence of an electromagnetic wave as the "radio" carrier. . Approximately 1884, Henry Poincaré define the vector and gave the theory of Poincaré, which describes the electricity flow in an area of electromagnetic radiation and allows accurate analysis of radio energy transfer systems. This theory followed the legitimacy of Henrik Rudolf Hertz's theory of 1888, of which there was evidence of radio waves. At the same time, two schemes of wireless signaling were placed by William Henry Ward (1871) and

Mahlon Loomis (1872), which were based on the false belief that there is an electric atmospheric layer at low altitude. Both the innovative patents mention that this layer connected with a return path using "Earth Currents" allows the wireless telegraph, as well as the telegraph supply power, to stay away with the artificial batteries and to be used for lighting, heat and purpose. Could power A more effective demonstration of radio transmission via Amos Dolbear's 1879 magneto electric telephone came out, which operated the ground for transmitting more than a quarter of a mile.

Bashrat 2013,]Proposed and developed an innovative charging techniques based on faradays law of electromagnetic induction where is EMF induced in coil, and the EMF induction is based on flux linkages between the two coils. The charging station produces energy and transmits it through the inductive coupler to an electrical storage. Time varying EM fields creates a coupling though anaigraphence forming an air core transformer and the rectified voltage from the secondary is used to charge the device.

Ibrahim 2017 paper showed an overview study and basis of the wireless mobile phones charging techniques where it was stated that wireless power transfer (WPT) can be defined as the electric energy transmit to an electric load from a power source without using a physical connection between them. WPT is allowing mobile devices to be continuously charged conveniently, easily and without constraints of using a power cord. Therefore an effective technique is demanded to enable energy transmission between charger station and users equipment without employing wire or other material .He also studied eCoupling at Fulton Innovation which is a bidirectional charging technology which would fundamentally permit someone to charge their mobile phone by simply putting it on the back of a tablet, .However there was no prototype developed as this was purely a survey work. International Journal of Electromagnetics and Applications

Elixabeth et all 2014 project is the creation of an inductive charging pad which allows a suitable, easy to use battery charging technique for mobile phones and other mobile devices. The work focuses on the problem of significant reduction of e-waste and de-cluttering of home and office space by eradicating the necessity

for power cords via the employment of wireless power transfer systems. The Inductive Charging Pad is a wireless power transfer method using inductive coupling to transfer electromagnetic energy from a charging station to handy devices. The project eliminates the need to constantly plug and unplug the device, with a successful implementation of this, the durability of the device would increase and its usage would become more convenient. The contribution made in this research is to further take inductive charging to its practical realization by using a high efficiency power transmitter capable of delivering more voltage for inductive charging. This 18 Design and Construction of a Prototype Wireless Power Transfer Device eradicates the problem of dead battery for mobile phones, wearable devices and supplies energy for remote charging of wireless sensor networks, wireless charging is set to change this by providing power wirelessly so that anywhere with the vicinity of the wireless charger the phone can charge continuously even while in use. According to WiTricity Corporation, [4] “wireless power transfer had succeeded to make these essential products more available, convenient, and reliable (in terms of availability of power to run them). The wireless power technology is very rea

### **2.2.2 Tesla**

After 1890, inventor Nikola Tesla tested the spark-powered radio frequency resonant transformer with the help of modern and capacitive coupling with power, which is now known as Tesla Coles, which produces high AC voltage. Then he tried to develop a radio lighting system based on nearby producers and managed a series of capacitive coupling and public protests where he published bright light bulbs from gisler tubes and even a stage. He can increase the distance that can illuminate a lamp using an acceptable LC circuit connected to the transmitter's LC circuit with resonance using similar recurring pairs. Tesla failed to produce a commercial product outside of his research, but his resonant's modern joint machine is now widely used in electronics and is currently being implemented on low-range wireless power systems.

Tesla went on to develop a radio power distribution system, which he hoped would be able to send a long distance of electricity and electricity. Early on, he

assumed borrowing from Mahlon Loomis, that the balloons created a system to suspend transmission of electrodes in altitude of 30,000 feet (9,100 meters) high and propose to supply electricity from where he feels that the pressure would send him high voltage will give (millions of volts) long distances.

In 1899, it established a test facility at high altitude in Colorado Springs, to study further the meteorological nature of low pressure air. He operated there in a large coil operating in the Megavolts range, and he examined the lightning strikes made from the electronic sound, he led there wrongly that he could use the entire world of the earth for the electrical power execution. This theory involves the driving of its resonant frequency, instead of the existing branches in the world, working against a higher capacitance to create the probability of world's prosperity from the driving Tesla coil. Tesla thought that it would allow similar electricity with similar capacitive antenna to carry power anywhere with little

electricity in any part of the



world.

Figure 2.1

Figure 2.1: Tesla's unsuccessful Wardenclyffe power station

His observations believe that the high voltage used in a coil at some feet height will "break down the air layer", eliminating the need for balloon missiles to create its atmospheric return circuits. Tesla used world's information and power broadcasts to offer "World Wireless System" in the following year. In 1901, he tried to build a large high-voltage radio power plant at Shoreham in New York, which is now called the Wardenclyffe Tower, but in 1904 the investment dried it and this facility never ended.

### *2.2.3 Nearby fields and non-radiation technology*

The modern power transfer was among the earliest wire cables, the first wireless power technology was developed in the 1800s, the transformer was available after it was developed. Induction heating has been used since the early 1900s. With the advent of cordless device, induction charging studies have been developed to overcome the dangers of electric shock for wet environment applications such as electric toothbrushes and electric razors. One of the first applications of formal transfers was the power of electric engines. In 1892, Morris Hutton and Maurice LeBalck patented a radio system for the power of train trains using Resouge Coils, which was connected to the 3KGJ track cable. The first passive RFID (Radio Frequency Identification) technology was invented by Mario Cardullo (1973) and Koelle (1975) and used in proximity cards and contactless smartcards in the 1990's. Recently, the expansion of portable wireless communication devices like mobile phones, tablets, and laptop computers has been developing mid-range wireless power and charging technologies to eliminate the requirements of connecting these devices to wall plugs during charging. Wireless Power Consortium was established in 2008 to develop standards for manufacturers throughout the world. Qi Inductive Power Standard, released on August 24, enables high efficiency charging and powering of portable devices up to 5 watts more than the distance of 4 cm (1.6 in). The wireless device is placed on a flat charger plate (for example, can be embedded at the top of the table in the cafe), and the charge is transferred from a flat coil to the device's equivalent one. In 2007, a team led by Marin Soljacic in MIT used a dual resonance transmitter to transmit the diameter of 10 mhz with 25 mm diameter and 10 watts (6.6 ft) (eight feet) of the transmitter coil diameter). In 2008, Greg Leigh and Mike Kane's team of Nevada Lightning Lab used a fixed dual resonance transmitter, with a radius of 60 cm radius of 57 cm radius, and using a similar grounded dual resonance receiver, a 12-meter (39 ft) distance was transferred through an electrical return circuit. In 2011, Christopher A. Professor Kevin Warwick of Tucker and Review University, Tesla 1900 Patent Revitalized 0,645,576 small scale and demonstrated power transmission with a coil diameter

of 10 cm (3.9 inches) on 4 meters (13 feet), resulting frequency of 27.50 MHz with 60.5% effective efficiency.

#### ***2.2.4 Microwave and laser***

Prior to World War II, there was little progress in wireless transmission. Radio was developed for communication purposes, but it cannot be used for power transmission because at least the frequency radio wave spreads from all directions and reaching a little power receiver. In radio contact with the receiver, an amplifier intensifies a weak signal using the power from another source. For power transmissions, transmitters need efficient transmitters that can create high frequency microwaves, which can be focused on narrow beams towards a receiver. During the First World War, the development of microwave technology, such as Barkhausen-kurz tube, magnetron tubes and parabolic antennas were created for the first time. The radiation (remote-field) method and the first long-distance wireless power transmission was achieved by William C. Brown in the 1960s. In 1964 Brown discovered Recta, which could convert the microwave into a DC Power efficiently, and in 1964 it was first shown with wireless-powered aircraft, a model helicopter powered by a microwave surrounded by soil. A major motivation for microwave research in the 1970s and 80s was the development of solar energy satellites. By Peter Glazer in 1968, it is assumed that it will collect energy from sunlight using solar cells and absorb the earth as a microwave in a large rectangle, which will convert electric power into electric power grids. As a technical director of the JPL / Reeththon program in 1975, 54% DC conversion expertise showed a long-range infection with a microwave out of microwave power 475 watt of Brown Microwave Power. In NASA's Jet Propulsion Laboratory, he and Robert Dickinson sent the 30- meter DC output power from 1.5 mph to 2.38 GHz microwave, from 26 m to 7.3 x 3.5 m rectangular air. The incident-Rafiq's DC conversion efficiency was 80%. In recent years, the focus of research has become a development of radio-propelled drone aircraft, which sponsored Brown's research with the Defense of Defense Rampe (Reithian Airborne Microwave Platform) project in 1959. Canada's Communication Research Center created a small prototype aircraft in 1987, known as the Stationary High Height Relay Platform (SHARP), which will restore the

telecommunications information among the world's points, such as the communication satellite. Driven by a recta, it can fly up to 13 miles (21 km) high and may stay high for several months. In 2003, NASA blasted the first laser-powered plane. Smaller model plane motors were powered by a ground-based laser from a bee of infrared light, powered by photocals, when a control system looked at the laser in the plane.

### 2.3 Basic Principles of Wireless Power Transfer

The radio was discovered by a person named Nikola Tesla who was "Father of Wireless", he is the one who the first person that conceived the idea of transmitting power through the air has been around for over century, with the Nikola Tesla's pioneer idea and his experiments attempts to do so. Most of the wireless power transfer systems use some electromagnetic (EM) fields that are sent to power.

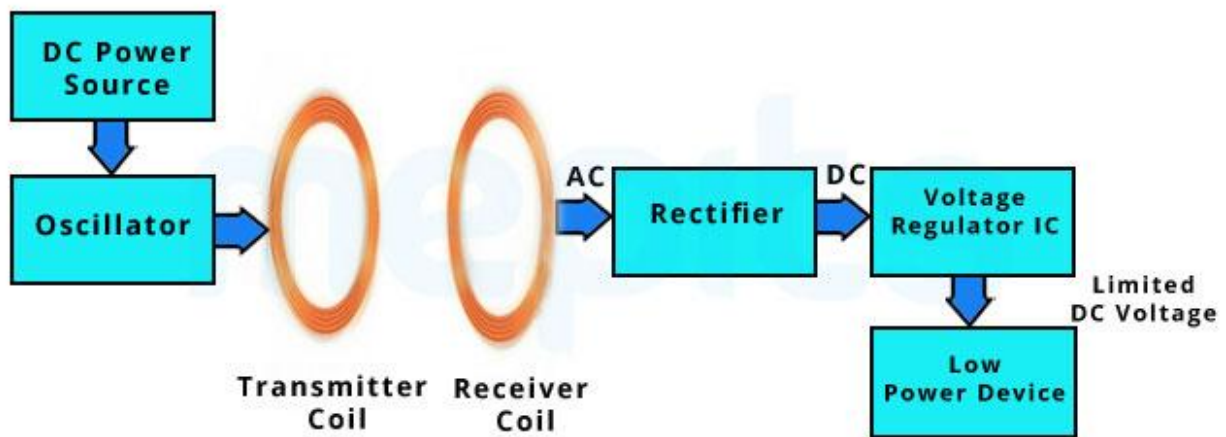

Figure 2.2

Figure 2.2 shows the simple block diagram of wireless power transfer.

There are three type of wireless power transfer that can use in wireless power transfer that is radiative transfer, inductive coupling and resonant coupling. Radiative transfer are suitable to exchange information and transfer a small power in milliwatts, most of it were wasted into free space. For inductive coupling, it can be transmitted the power with high efficiency but in very short distance.

Last type is resonant coupling, it can transfer high power at medium distance. Basic principles of resonance system based on the possibility of forming two separate coils with same frequency similar to high frequency magnetic coupling and high exchange capacity.

#### **2.4 Justification for the Study**

The capacity for wireless transmission capabilities has increased over the years. Currently a research is being conducted to obtain the appropriate method that can be used in lots of uses such as device development. The following are reasons why it is important:

a) Flexibility: WPT conductors and cable use will be removed. Instead, there are many wiring power running on power devices from power sources that can be sent wirelessly, so avoid mess created by wire and many more devices can be driven without having all their energy sources.

b) Safety: With the increase in electrification in the area, there are electric shock cases people even the animals have been rampant to end up touching the conveyor. WPT will exhaust the conductors thus preventing electric shock.

c) Convenience: Convenient use of WPT application devices will be enabled. For example, the pacemaker in the medical field that uses the battery can be re-branded battery life is over when compared to having every surgical. For this, the cost will be saved surgery and more a convenient alternative.

d) Reliability: Many times people are using a device and it runs out of power yet one doesn't have a cord to charge the device or perhaps there is no source of power around. However with WPT the devices can be charged wirelessly hence the risk of low battery power will be eliminated.

#### **2.5 Main concepts of wireless transmission of electric energy**

As a result of the extensive research in WPT, various categories have arisen. WPT can be categorized in terms of efficiency, distance of transmission, power level and size. Classification based on distance of transmission however is more relevant.

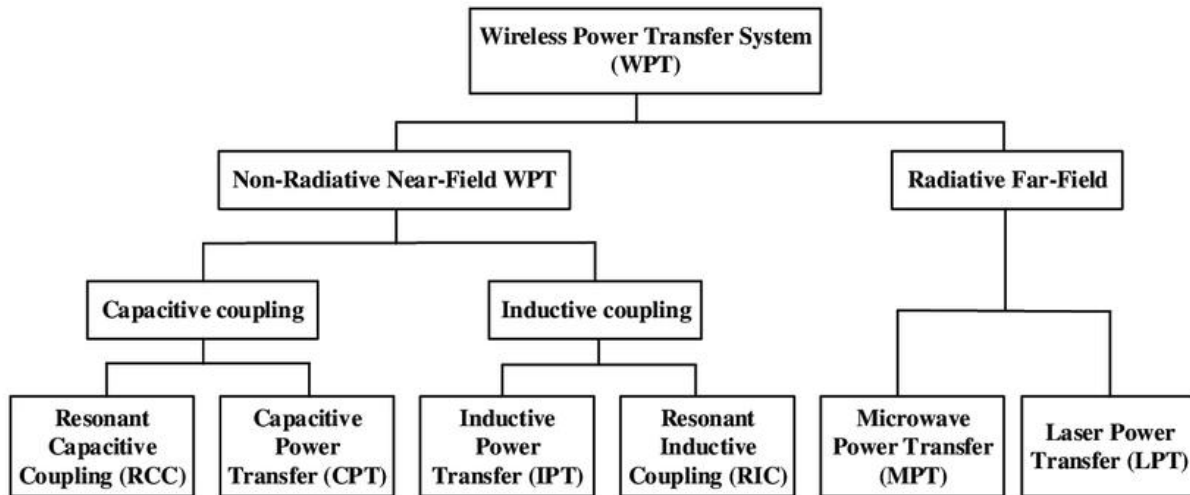

Figure 2.3

Figure 2.3: Classification of WPT

For both electromagnetic sources electric (e-fields) and magnetic (H-field) fields are created around it. These fields are characterized by radioactive and non-radiation components. Depending on the distance from the source they can be close to the field, near the transfer zone or the remote area. Transit area has both the transfer characteristics of nearby and far fields. The area of adjacent field can be said to be found in the radius of the wavelength, where the fields are located outside the radius of two wavelengths. However, it is less than the wavelength for transmitters and receivers. Far field transfer is only one type, whereas all polarization types in the adjacent field movements are vertical, horizontal, elliptic and circular. The study found a high efficiency during transfer time so far near the transfer place. This can be attributed to both reducing electrical and magnetic fields proportionally the distance from the source. In addition, the neighboring region allows higher division of the wave, resulting in a strong range of strong sharpness and weak direction. In all this light, more research has been done to improve the relocation of remote areas compared to remote field transfers. Both near field transfer and far field are further categorized based on the method of operation of the transfer. Some of the methods are as follows:

**Far Field Transfer:**

a) Microwave Power transfer in this method, the DC is supplied to the microwave generator, which is converted into microwaves. Radioactivity occurs through the coaxial-waveguide adaptor and then through the waveguide circular, which reduces the radiation from external energy

Finally, the radiation flows through the tuner and directional coupler device, which separates the signal according to the direction of the signal transmission. The radiation is then transmitted through the antenna on the air, where it is obtained by antenna in rectennal, where microwave radiation passes through a low pass filter, then a matching network and then it is converted into DC as a rectifier.

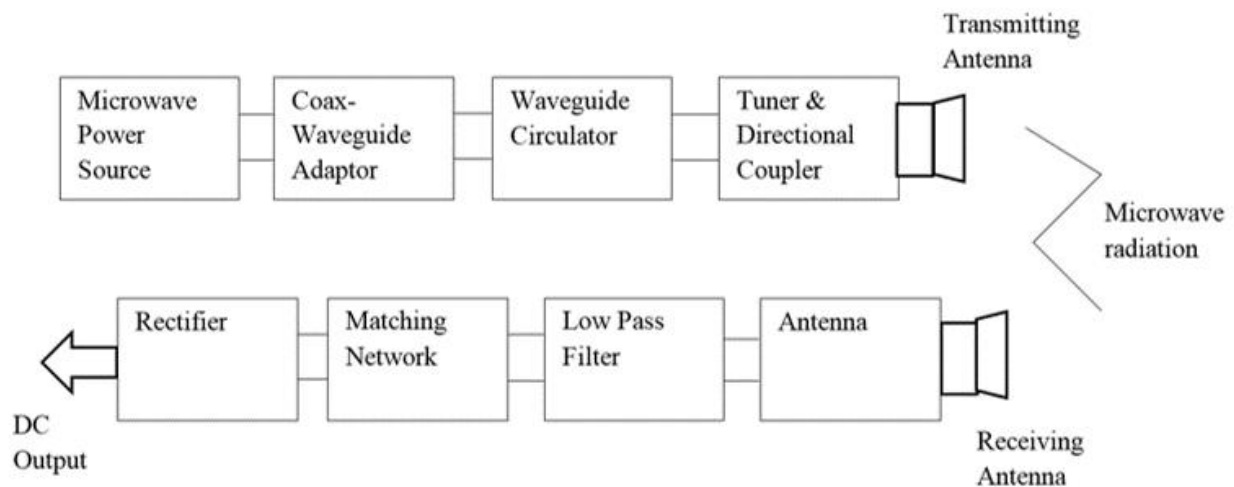

Figure 2. 4

Figure: 2.4: Microwave Power Transfer

b) Photo electricity

c) Propagating electromagnetic waves

## 2.6 Wireless transfer by Inductive Coupling

Wireless transmission capabilities are based on the right reasons for electromagnetic field correctly electromagnetic induction. Biot-Savart's law, Which is similar to the laws of Coulomb, states that the magnetic field intensity  $dH$  at  $r$  due to the current element  $I dl$  at  $r'$  is  $dR$ . It gives the relation between the magnetic field and the length, direction, proximity and current length of electricity through which it has been created.

$$dB = \frac{I dl \times R}{4\pi R^3}$$

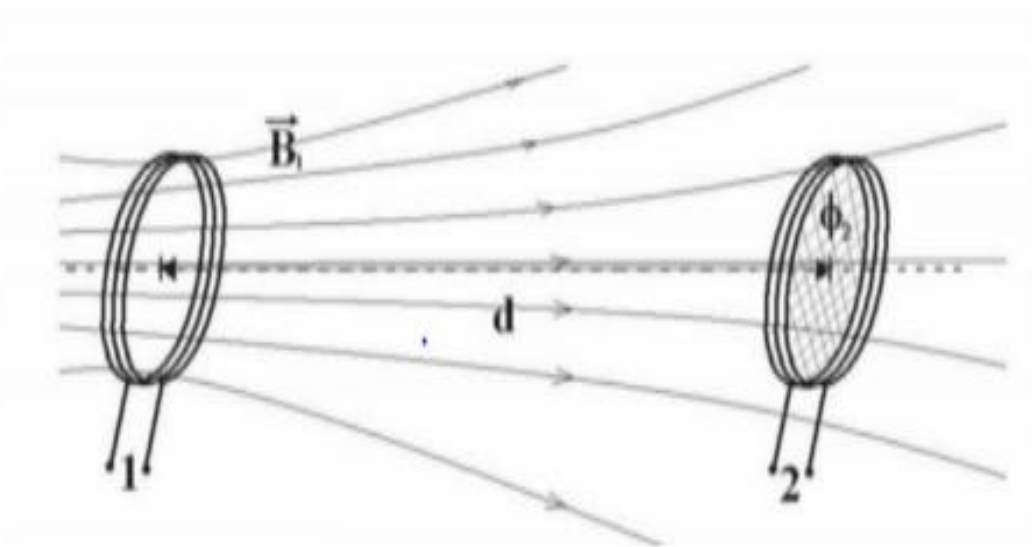

Figure 2. 5

Figure: 2.5: Magnetic flux

Where  $R$  is the full displacement vector from the current source to the field point,  $I dl$  infinitesimal current source point in the wire. A magnetic field of  $B_r$  is produced by the copper coil. The magnitude of the magnetic field is affected by  $r$  which is the distance of the field point from the center of the coil. Magnetic field  $B$  coil current  $i$  proportional. Suppose two copper laminated coils are located near the field while grabbing as well as combine one magnetic field is generated. However, only the transmitter coil is operated and current flows through it. This magnetic field created by TX coil at point  $x$  is being made in the RX coil.

$$B = \frac{\mu_0 N I a^2}{2(a^2 + d^2)^{3/2}}$$

Where N is the number of coil spin, I is the current of the transmitter current, it is a radius TX quilts are the separation distance between and TXX. Rx will be given by the magnetic flux that will pass through the coil:

$$\Phi = \iint_s B dS$$

Magnetic flux density generated by B transmitter and ST receiver coil surface area.

In the transmitter coil current is flowing, depending on the time the receiver creates magnetic flux variations in the coil. An electromotive force (emf) will be induced in RX coil which is obtained by applying Faraday's law of induction which states that "The induced emf  $\epsilon$  in a coil is proportional to the negative of the rate of change of magnetic flux".

$$\epsilon = - \frac{d\Phi}{dt}$$

For a coil that contains n loops, the total motivated MMF will be large

$$\epsilon = -N \frac{d\Phi}{dt}$$

Where  $\Phi$  is the magnetic flux. EMF tech coil is currently driving magnetic fields are opposed to the change in the timing of magnetic flux in accordance with Lenz's law. Therefore, the power is transferred from the TX coil to the RX coil. An MMF can be launched in the following way:

- (i) By varying the magnitude of B with time as in the figure below5

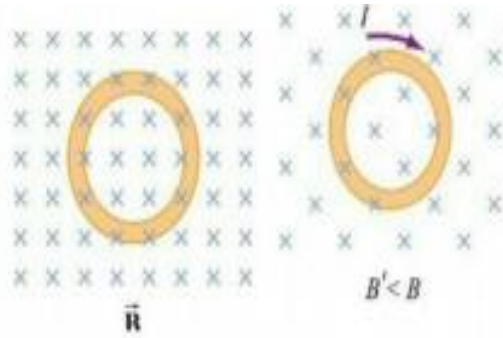

Figure 2. 6

Figure 2.6: Magnitude of B

- (ii) By varying the magnitude of A, i.e., the area enclosed by the loop with time.

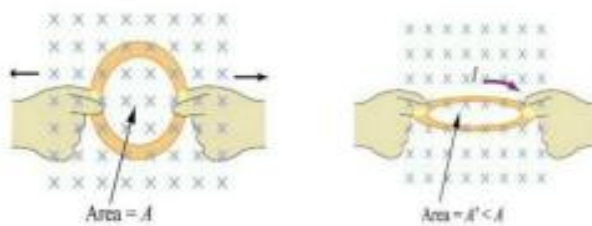

Figure 2. 7

Figure 2.7: Magnitude of A

The property of self-inductance circuits opposes the current change of its own magnetic field circuits. Self-inductance of the coil can be defined as:

$$L = N \Phi / I$$

Where N is the number of these magnetic flux and I have the coil current.

Therefore,

$$\varepsilon = -L \frac{dI}{dt}$$

Or

$$\varepsilon = -M \frac{dI}{dt}$$

Where L is self-inductance of the coil, M is mutual inductance of two coils, I is the current of the coil. So the emf induced in the coil directly proportional to the mutual inductance of the coils and rate at which the current is oscillating. Mutual inductance can also be given

$$M = k(L_1 L_2)^{1/2}$$

Where k is the coupling factor, L1 and L2 are TX and RX inductances. Coupling factor determines the grade of coupling, i.e. how much the total flux has entered inside receiver coil if the current option is,

$$\Phi = \frac{\mu_0 N I \sin(\omega t) a^2}{2(a^2 + d^2)^{3/2}}$$

Therefore,

$$\varepsilon = - \frac{d\left(\frac{\mu_0 N I \sin(\omega t) a^2}{2(a^2 + d^2)^{3/2}}\right)}{dt}$$

It clearly shows that the voltage introduced in the second coil depends on current and voltage in the primary coil, current and voltage frequency in the primary coil, the separation distance between coils and coil's surface area. As a result, two coil coupling systems are illustrated below.

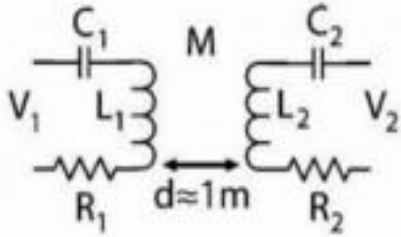

Figure 2. 8

Figure 2.8: The two coil coupling system

Connectors representing C1 and C2 are tuning capacitors, L1 and L2 are mutual inductance M, R1 and R2 are composite resistance. d is the distance between the coils and V1 and V2 are input and output voltages. Second coil output can be defined as energy:

$$P_{out} = \frac{V_1^2 \omega^2 M^2 R_l}{(R_1(R_2 + R_l) + \omega^2 M^2)}$$

Where  $\omega$  is the operating frequency of the system,  $R_l$  is load resistance.  $R_l$  is load resistance. Thus the overall efficiency of the system depends only on transmission frequency, mutation, coils' parasite resistances and load resistance. The Q factor which is defined as the proportional proportion of the resistance coil energy is performed and determines the overall efficiency of the system. A high Q factor a low power loss and so good means the transmission efficiency. Generally there are question factor values from 0 to 1000 for WPT coils. It is defined as:

$$Q = \frac{\omega L}{R}$$

Where L is the inductance of the coil, R is its resistance and is the operating frequency of the system. Of course, increasing the operating frequency increases the Q factor. However, when it is reaching its peak value, it will decrease as the operating frequency continues to rise. A higher Q factor means a narrow band-

width, thereby allowing dropping coupling efficiency and a tuning circuit. Maximum transfer efficiency is defined by:

$$\eta = \frac{k^2 Q_1}{\left(1 + \sqrt{1 + k^2} Q_1 Q_2\right)^2}$$

Where  $k$  is the coupling factor between two coils,  $Q_1$  and  $Q_2$  are the quality factors of the transmitter and receiver coils. As a result, to reach maximum efficiency, developers should optimize their system coupling and quality reasons.

## 2.7 Advantages of Wireless Charger

1. Safe for human, simple implementation.
2. Charging multiple devices simultaneously with multiple capacities, high charging skills.
3. It improves user-friendliness as the hassle from connecting cables is removed. Different models of different brands and devices can use the same charger.
4. It increases flexibility, especially in devices for which batteries or replacement chargers for charging are expensive, dangerous, or disabled (eg body-implanted sensors).
5. It render the design and fabric of many smaller devices without battery attachments.
6. It provides better product durability (e.g., waterproof and dustproof) for contact-free devices.
7. If wireless communications are not acceptable or wireless charging is convenient and the product is embedded in the product or the product cannot reach. Wireless charging is usually used in medical devices and food products where electric shock or bacterial layers should be kept to the lowest and no electrical contact is allowed.

8. Wiring charging can also reduce the amount of cables and power adapters you need to have custom manufactured for your device or application.

9. Wireless charging can be sized to deliver 5W or 10W of energy to the battery. It can be a good solution to charge your battery. It can charge your battery at a faster speed, depending on the size of the battery pack.

10. In most applications the distance between the two coils is typically 5mm. It is possible to extend the extent to at least 35 mm.

## **2.8 Disadvantages of wireless Charger**

1. The main disadvantages of wireless charging is low efficiency and heat dissipation. It has low efficiency and resistant heat is more than direct contact charging. It is advised to keep the device on the mat and keep it cool. It is easily charged.

2. One of the reasons that wireless charging has not been fully integrated is that it can still be slower and less efficient than a traditional charger. It is important to mention that this factor is technology based. Some wireless chargers can not only reach the same level of efficiency as traditional charging, so the process continues to be slow. In addition, the heat produced in certain types of wireless charging technologies is generally more than the conventional method of charging.

3. Mobility: Must have mobile device pad for charge. It cannot be moved around with it as with direct contact charger with cable. It cannot be operated during charging. Though the signal transmitted between your smartphone and the charging station is wireless, it is still necessary to plug the charging station to the wall. Therefore, the devices currently available on the market are not portable and therefore do not allow you to 'continue'. If you have a plug for the human chain charging stations, then come with a portable battery that can be charged. Go till there is enough power to maintain its energy.

## **2.9 Summary of the chapter**

This chapter elaborates on the method of wireless power transfer that was selected which is inductive coupling. Ending of this chapter we know about

wireless transfer by inductive coupling, and advantages and disadvantages of wireless charger.

## CHAPTER 3

### DESIGN AND METHODOLOGY

#### 3.1 Introduction

This section gives the actual design and calculations carried out to obtain component values, also specifications on manufacturer data sheet were considered. Four main sections shown in the block diagram as shown below:

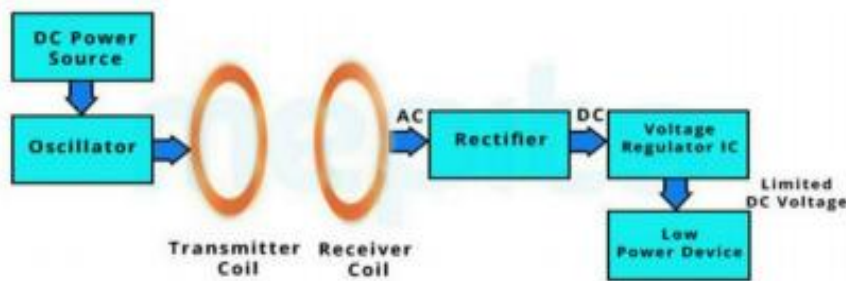

Figure 3.1

#### 3.2 DC power source

A DC power source of 5V is used based on the circuit requirement.

##### 3.2.2. Coils

The transmitter coil and receiver coil are explained in the previous chapter where the equivalent circuit for coils and resonator are shown. The structures of transmitter and receiver coils are as Table shown below. However, due to the unavailability of 0.9 mm of enameled copper wire, the coil used in this project was replaced by 1 mm of enameled copper wire. The enameled copper wire was hand wound into circular shape with the diameter of 70 mm.

MATERIALS	ENAMELED COPPER WIRE
Number of turns for each coils, N	5
Diameter of turns, mm	70
Diameter of coil, mm	1
Shape of turns	Circular

### 3.3 Basic Configuration of a Buck Converter

Figure 1 shows the basic configuration of a buck converter where the switch is integrated in the selected integrated circuit ( IC). Some converters have the diode replaced by a second switch integrated into the converter (synchronous converters). If this is the case, all equations in this document apply besides the power dissipation equation of the diode.

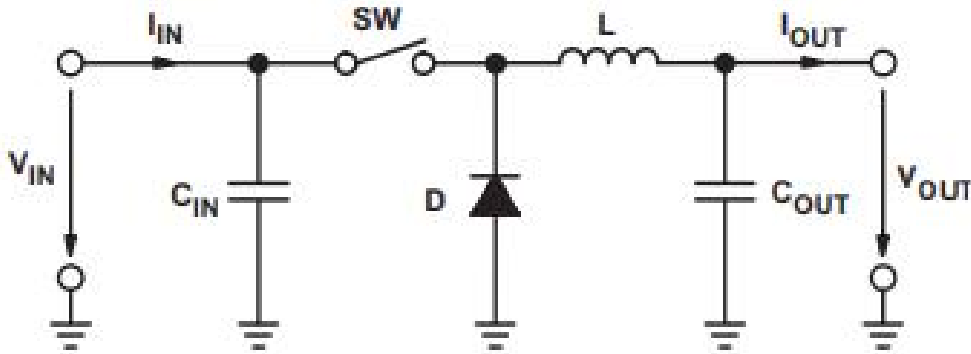

Figure 3.1.1. Buck Converter Power Stage

#### 3.3.1 Necessary Parameters of the Power Stage

The following four parameters are needed to calculate the power stage:

1. Input voltage range:  $V_{IN}(\min)$  and  $V_{IN}(\max)$
2. Nominal output voltage:  $V_{OUT}$
3. Maximum output current:  $I_{OUT}(\max)$
4. Integrated circuit used to build the buck converter. This is necessary because some parameters for the calculations must be derived from the data sheet.

If these parameters are known, the power stage can be calculated.

#### 3.3.2 Calculate the Maximum Switch Current

The first step to calculate the switch current is to determine the duty cycle,  $D$ , for the maximum input voltage. The maximum input voltage is used because this leads to the maximum switch current.

$$\text{Maximum Duty Cycle: } D = \frac{V_{OUT}}{V_{IN(max)} \times \eta}$$

VIN(max) = maximum input voltage

VOU = output voltage

η = efficiency of the converter, e.g., estimated 90%

The efficiency is added to the duty cycle calculation, because the converter also has to deliver the energy dissipated. This calculation gives a more realistic duty cycle than just the formula without the efficiency factor.

Use either an estimated factor, e.g., 90% (which is not unrealistic for a buck converter worst-case efficiency), or see the Typical Characteristics section of the data sheet of the selected converter.

The next step in calculating the maximum switch current is to determine the inductor ripple current. In the converter's data sheet; normally, a specific inductor or a range of inductors are named for use with the IC. So, use the recommended inductor value to calculate the ripple current, an inductor value in the middle of the recommended range, or if none is given in the data sheet, the one calculated in the Inductor Selection section of this application report.

$$\text{Inductor Ripple Current: } \Delta I_L = \frac{(V_{IN(max)} - V_{OUT}) \times D}{f_S \times L}$$

VIN(max) = maximum input voltage

VOU = desired output voltage

D = duty cycle calculated in Equation 1

f = minimum switching frequency of the converter

L = selected inductor value

It now has to be determined if the selected IC can deliver the maximum output current.

$$\text{Maximum output current of the selected IC: } I_{\text{MAXOUT}} = I_{\text{IM(min)}} - \frac{\Delta I_L}{2}$$

$I_L$  = minimum value of the current limit of the integrated switch (given in the data sheet)

$\Delta I_L$  = inductor ripple current calculated in Equation 2

If the calculated value for the maximum output current of the selected IC,  $I_{\text{MAXOUT}}$ , is below the system's required maximum output current, the switching frequency has to be increased to reduce the ripple current or another IC with a higher switch current limit has to be used. Only if the calculated value for  $I_{\text{MAXOUT}}$  is just a little smaller than the needed one, it is possible to use the selected IC with an inductor with higher inductance if it is still in the recommended range. A higher inductance reduces the ripple current and therefore increases the maximum output current with the selected IC. If the calculated value is above the maximum output current of the application, the maximum switch current in the system is calculated:

$$\text{Application specific maximum switch current: } I_{\text{SW(max)}} = \frac{\Delta I_L}{2} + I_{\text{OUT(max)}}$$

$\Delta I_L$  = inductor ripple current calculated in Equation 2  $I_{\text{OUT(max)}}$  = maximum output current necessary in the application This is the peak current, the inductor, the integrated switch(es), and the external diode have to withstand.

### 3.3.3 Inductor Selection

Data sheets often give a range of recommended inductor values. If this is the case, choose an inductor from this range. The higher the inductor value, the higher is the maximum output current because of the reduced ripple current. In general, the lower the inductor value, the smaller is the solution size. Note that the inductor must always have a higher current rating than the maximum current given in Equation 4; this is because the current increases with decreasing

inductance. For parts where no inductor range is given, the following equation is a good estimation for the right inductor:

$$L = \frac{V_{OUT} \times (V_{IN} - V_{OUT})}{\Delta I_L \times f_S \times V_{IN}}$$

VIN = typical input voltage

VOU = desired output voltage

fS = minimum switching frequency of the converter

ΔIL = estimated inductor ripple current, see the following:

The inductor ripple current cannot be calculated with Equation 1 because the inductor is not known. A good estimation for the inductor ripple current is 20% to 40% of the output current.

$$\Delta I_L = (0.2 \text{ to } 0.4) \times I_{OUT(max)}$$

ΔIL = estimated inductor ripple current

IOUT(max) = maximum output current necessary in the application

### 3.3.4 Rectifier Diode Selection

To reduce losses, use Schottky diodes. The forward current rating needed is equal to the maximum output current:

$$I_F = I_{OUT(max)} \times (1 - D)$$

IF = average forward current of the rectifier diode

IOUT(max) = maximum output current necessary in the application

Schottky diodes have a much higher peak current rating than average rating. Therefore the higher peak current in the system is not a problem. The other parameter that has to be checked is the power dissipation of the diode. It has to handle:

$$P_D = I_F \times V_F$$

$I_F$  = average forward current of the receiver diode

$V_F$  = forward voltage of the rectified diode

$D$  = duty cycle calculated in Equation 1

### 3.3.5 Output Voltage Setting

Almost all converters set the output voltage with a resistive divider network (which is integrated if they are fixed output voltage converters). With the given feedback voltage,  $V_{FB}$ , and feedback bias current,  $I_{FB}$ , the voltage divider can be calculated.

The current through the resistive divider needs to be at least 100 times as big as the feedback bias current:

$$I_{R1/2} \geq 100 \times I_{FB}$$

$I_{R1/2}$  = current through the resistive divider to GND

$I_{FB}$  = feedback bias current from data sheet

This adds less than 1% inaccuracy to the voltage measurement and for the calculation of the feedback divider, the current into the feedback pin can be neglected. The current also can be a lot higher. The only disadvantage of smaller resistor values is a higher power loss in the resistive divider, but the accuracy is increased a little. With the preceding assumption, the resistors are calculated as follows:

$$R_2 = \frac{V_{FB}}{I_{R1/2}}$$

$$R_1 = R_2 \times \left( \frac{V_{OUT}}{V_{FB}} - 1 \right)$$

$R_1, R_2$  = resistive divider, see

VFB = feedback voltage from the data sheet

IR1/2 = current through the resistive divider to GND, calculated in Equation 9

VOOUT = desired output voltage

### 3.3.6 Input Capacitor Selection

The minimum value for the input capacitor is normally given in the data sheet. This minimum value is necessary to stabilize the input voltage due to the peak current requirement of a switching power supply. The best practice is to use low-equivalent series resistance (ESR) ceramic capacitors. The dielectric material must be X5R or better. Otherwise, the capacitor loses much of its capacitance due to dc bias or temperature. The value can be increased if the input voltage is noisy.

### 3.3.7 Output Capacitor Selection

best practice is to use low-ESR capacitors to minimize the ripple on the output voltage. Ceramic capacitors are a good choice if the dielectric material is X5R or better. If the converter has external compensation, any capacitor value above the recommended minimum in the data sheet can be used, but the compensation has to be adjusted for the used output capacitance. With internally compensated converters, the recommended inductor and capacitor values must be used, or the recommendations in the data sheet for adjusting the output capacitors to the application in the data sheet must be followed for the ratio of  $L \times C$ . With external compensation, the following equations can be used to adjust the output capacitor values for a desired output voltage ripple:

$$C_{OUT(min)} = \frac{\Delta I_L}{8 \times f_S \times \Delta V_{OUT}}$$

COUT(min) = minimum output capacitance

$\Delta I_L$  = estimated inductor ripple current

fS = minimum switching frequency of the converter

$\Delta V_{OUT}$  = desired output voltage ripple

The ESR of the output capacitor adds some more ripple, given with the equation:

$$\Delta V_{\text{OUT(ESR)}} = \text{ESR} \times \Delta I_L$$

$\Delta V_{\text{OUT(ESR)}}$  = additional output voltage ripple due to capacitors ESR

ESR = equivalent series resistance of the used output capacitor

$\Delta I_L$  = inductor ripple current from Equation 2 or Equation 6 Often the selection of the output capacitor is not driven by the steady-state ripple, but by the output transient response. The output voltage deviation is caused by the time it takes the inductor to catch up with the increased or reduced output current needs. The following formula can be used to calculate the necessary output capacitance for a desired maximum overshoot:

$$C_{\text{OUT(min),OS}} = \frac{\Delta I_{\text{OUT}}^2 \times L}{2 \times V_{\text{OUT}} \times V_{\text{OS}}}$$

$C_{\text{OUT(min),OS}}$  = minimum output capacitance for a desired overshoot

$\Delta I_{\text{OUT}}$  = maximum output current change in the application

$V_{\text{OUT}}$  = desired output voltage

$V_{\text{OS}}$  = desired output voltage change due to the overshoot

### 3.4. Principle of operation

Circuit has been divided into two categories:

1. Transmitter circuit
2. Receiver circuit

#### 3.4.1. Transmitter circuit

This subsystem encompasses the transmitter section of the system which operates on the principles of electromagnetic induction. Inductive charging also known as (wireless charging or cordless charging) is a type of wireless charging that uses an electromagnetic field to transfer energy between two objects using electromagnetic induction which is the production of electricity across a magnetic field. Inductive charging is usually done with a charging station or inductive pad (transmitter). Energy is sent through this transmitter which in turn delivers this energy to a receiver wirelessly which then utilize this energy to charge batteries or run electronic devices. Induction chargers use an induction coil to create an alternating electromagnetic field from within a charging base, and a second induction coil (receiver) in the portable device takes the power from the EM field and converts it back into electric current to charge batteries. The two coils in proximity combine to form an electrical transformer. It should be noted that the greater the distance between the two coils the lower the power received. Although greater distances between transmitter and receiver can be achieved using resonant inductive coupling, our project adapts the inductive coupling method of wireless power transfer.

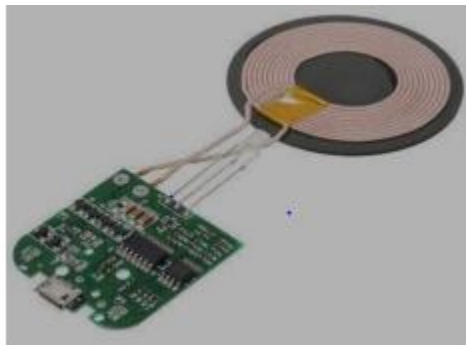

Figure 3. 2

Figure 3.2 : Pictorial Diagram of an inductive transmitter coil.

#### Factors that affects the transmitter coil

##### A. Coil Shape.

The shape of coil used as antenna will determine the area to which the power will be transmitted.

##### B. Coil Impedance

Maximum power will be transmitted if transmitting coil's impedance is equal to receiving coil impedance which could be achieved by resonating both sending and receiving coil's at a similar resonating frequency.

##### C. Distance between coils

The total distance between two coils i.e. sending and receiving coils also affects the power transmitted too. Usually the transmitted power reduces inversely proportional to the increase in distance.

##### D. Number of coils

The number of coils used as transmitter and receiver affects the transmitted power directly. With increase in coils used, the complexity of the circuit also increases.

##### E. Intermediate Coils, if any

Intermediate coils, if used must be perfectly matched with the impedance of the transmitting and receiving coil impedance, thus providing potential to increase the distance vastly.

##### F. Area of coils turn

The area of the coils turn will affect the power transmitted directly as with increase in coil's area, its range will also improve.

##### G. Coil Alignment

The alignment of transmitter/receiver coil would affect the power transmitted from one end to other. There are two different forms of misalignment that could occur

- Lateral misalignment: Coils are in parallel, but their centers do not meet horizontally or vertically.
- Angular misalignment: Centers of both transmitter and receiver coil are well aligned but the coils are turned by an angle

### **3.4.2 Receiver Circuit**

This subsystem consists of the receiver coil component of the charging system, this subsystem takes the transmitted power induced wirelessly from the transmitter and converts the alternating current back to direct current. The receiver subsystem has a rectifier interfaced to it which does this conversion of currents.

### **Working of transmitter circuit**

This project is made of a DC power source, in the transmitter module (Commonly known as an electrode) and a transmitter coil.

### **DC Supply**

DC power source consists of a 12v supply.

### **Transmitter coil**

The transmitter coil for this project was built with 9 mm diameter, 17 swg copper wires and 100 turns. From the inductance of a single layer air core coil, we inductance  $L = 8.1 \mu\text{H}$ .

### **Working of receiver circuit**

The receiver module of our project consists of a receiver coil, a rectifier circuit and a voltage Regulator IC And additional wild converter get more current by reducing the 5 volt output voltage.

## Receiver Coil

The receiver coil for our project is designed as a transmitter coil with the same quality.

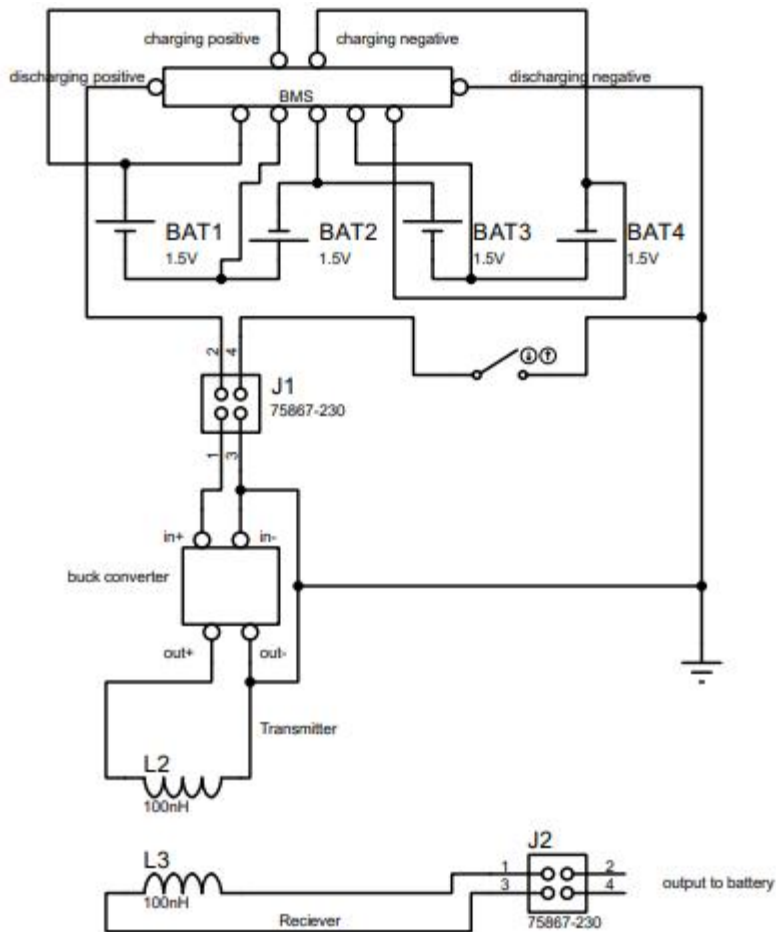

Figure 3.5 circuit diagram of a wireless charger

### 3.5 Components

Required components

4 batteries(1.5v each)

1 BMS

1 buck converter

25 Gauge wire

Diode 4 , for making a bridge connection round anything for coil winding

12 volt power supply

1 Bread board

1 charging port

### **3.6 Summary**

This section gives a detailed explanation of how to combine devices once. It also explains the components used and their role in the design of each part of the device .In this we known about components which are required for this project.

## CHAPTER 4

### RESULTS AND DISCUSSIONS

#### 4.1 Results

The main purpose of the project was to develop a device for wireless power transfer. The device will be an electronic circuit. The objectives of achieving this goal were divided into specific objectives, which together helped to improve the device. Other objectives were as follows:

1. Design and assemble a power supply unit. Power supply provides high frequencies from 230V AC to 12V AC. 12V DC is then fixed to give 5V DC.
2. Step down DC supply. Using a bulk converter, the DC voltage is reduced to 5V DC.
3. Develop transmitters and receiver coils. Electromagnetic induction occurs between two coils and an emf generated on the TX coil that induces a current on the RX coil. The coils were embedded on the fabricated casing of the modules. However the receiver coil is in the figure below:
4. Design receiver module and rectify the AC voltage found in receiver coil. DC power output needed a correction that would be used for power Element.

#### 4.2 Analysis and Discussion

##### 4.2.1 Coil

To test whether the power was sent, we first sold a LED in the receiver coil. The test was there Oscillator power only succeeded with 5V DC. But power was also good enough battery charging circuit made of an LCD and microprocessor. Voltage step by step up to 30V DC uses a boost converter. Two used coils were used and each had an LED lamp. They both shine brightly. We then added a set of LEDs and the results below were the results. The acceptable cables were not separated from the transmitter coil. But as though increase the separation distance separating brightness. This proves that this is really the distance separation determines the current introduced into the receiver coil. Increase the

distance, less the current flux is inspired from the changes. Tested LED bulbs lit up bright up to a separation their brightness decreases significantly after the distance of 5 cm in two kilometers. Also, the gauze used in the coil is more effective. Currently the most common gauge in market is 26 and gauge 16. It was noted for gauge coils 16, the separation distance between the coils was small and also bright the bulb gauge was less than 26. Various objects were placed in the receiver heat dissipation. They were connected with them. Voltage stepped up to 30V DC at the primary level of the transmitter circuit The first MOSFET still did not flush fast. That is the reason that it has been discovered voltage is being fed to a short circuit power until it is very slowly growing. To solve this problem, a reset switch was introduced into power supply and oscillator circuits. Switch also MOSFETs are able to reset the circuits once heated. It is also noticed that as long as the voltage has been increased to the oscillator, the power is much higher Battery charging circuit strength obtained on the load coil was not enough. This was it Because the receiver coil is slightly out of resonance, it was not able to take it this way Power is good For this solution we are sure that the same number of coils and used capacitors were identical, so that the transmitter and receiver circuit were both the same resonated frequency.

### 4.2.2 Battery charging circuit

A **battery management system (BMS)** is any electronic system that manages a **rechargeable battery (cell or battery pack)**, such as by protecting the battery from operating outside its safe operating area, monitoring its state, calculating secondary data, reporting that data, controlling its environment, authenticating it and / or **balancing** it.

A **battery pack** built together with a battery management system with an external communication **data bus** is a **smart battery pack**. A smart battery pack must be charged by a **smart battery charger**.

A BMS may monitor the state of the battery as represented by various items, such as:

- **Voltage**: total voltage, voltages of individual cells, or voltage of periodic taps
- **Temperature**: average temperature, coolant intake temperature, coolant output temperature, or temperatures of individual cells
- Coolant flow: for air or fluid cooled batteries
- **Current**: current in or out of the battery

### 4.3 Summary

The goal of this project was to develop and implement a wireless charger for low power devices through a resonant linkage connection. After analyzing the entire system for step-by-step optimization, a circuit was designed and implemented. Experimental results show that significant improvements in terms of power transfer skills have been achieved. As it was mentioned earlier, wireless charging could be the next big thing and transmitter coil to protect sending power has an effect. It is observed that it was not any significant influence on the power that is transmitted. However when there was a magnetic element in Coils it was an effect to place within.



## CHAPTER 5

### CONCLUSION AND RECOMMENDATION

#### 5.1 Conclusion

The objectives of the project were met. An electronic device/platform that wirelessly transmits power to charges mobile phones was developed. We were able to design discrete components such as the multiple power supply unit, the oscillators, transmitter and receiver coils and a full bridge voltage rectifier for the system design process. Conclusions that were drawn from the project are as follows:

1. Based on the theory of wireless power transfer using inductive coupling, which was the method used in this project, it was seen that various aspects i.e. distance, resonant frequency, quality factor, coil turns ratio determine the efficiency of WPT. In addition, there is an exponential decay for power versus the distance of separation.
2. From the analysis it was seen that at 0cm separation distance, the power transfer was most efficient.
3. From the project WPT for short range or near field occurred up to a distance of 5cm after which the power transferred began to significantly drop.
4. We also concluded that WPT can be used in other applications. In the project we were able to charge a 5V battery from power that was transmitted wirelessly.
5. Lastly, we can conclude that WPT is not affected by non-magnetic materials shielding the two coils. This therefore means that it can be effectively used in the medical field to charge pacemakers and other devices.

#### 5.2 Recommendations

From this project write up we were able to get a preliminary analysis of the design of a wireless transfer system. However, more research and improvement is required in order to realize a more practical system. Based on the challenges faced during the design and observations, the following are recommendations for

future work: Research on the variation of the Q factor and damping factor this can be done by designing a receiver circuit which is in synchrony with the transmitter circuit. Studying on the effect of using multiple receivers on the power output, a major challenge in the design was obtaining a reasonable amount of power. This study can investigate if the power obtained in the receiver will be higher. Research on a better, efficient circuit: Power amplifier needs to be studied in order to achieve better frequency stability, more power and efficiency.

## REFERENCES

[1] WPT-wikipedia <https://en.m.wikipedia.org/wiki/wpt>.

[2] Energypedia: history of wireless power transmission.

[3] Brown, William C. The History of Power Transmission by Radio Waves [online]. Microwave Theory and Techniques, IEEE Transactions on (Volume: 32, Issue: 9); September 1984, 1230-1242. URL: <http://ieeexplore.ieee.org.ezproxy.metropolia.fi/stamp/stamp.jsp?tp=&arnumber=1132833> Accessed 13 October 2014.

[4] Mark Estabrook. The convenience of wireless charging: It's just physics. White paper [online]. MediaTek, 2013. URL: [http://cdn-cw.mediatek.com/Mediatek\\_Wireless\\_Charging.pdf](http://cdn-cw.mediatek.com/Mediatek_Wireless_Charging.pdf) Accessed 30 August 2014.

[5] Nikola Tesla. The transmission of electrical energy without wires. Selected Tesla writings [online]. Electrical World and Engineer, 2011. URL: <http://www.tfcbooks.com/tesla/1904-03-05.htm> Accessed 10 November 2019.

[6] Morris Kesler. Highly Resonant Wireless Power Transfer: Safe, Efficient, and over Distance. White Paper [online]. WiTricity Corporation, 2013. URL: <http://www.witricity.com/assets/highly-resonant-power-transfer-kesler-witricity-2013.pdf> Accessed 15 November 2019.

[7] Matias, R.; Cunha, B.; Martins, R. Modelling inductive coupling for Wireless Power Transfer to integrated circuits [online]. Wireless Power Transfer (WPT), 2013 IEEE; 15-16 May 2013, 198–2014. 93

URL:<http://ieeexplore.ieee.org.ezproxy.metropolia.fi/stamp/stamp.jsp?tp=&arnumber=6556917> Accessed 11 November 2019.

[8] Richard Wolfson. Essential University Physics: Volume 2 (Second Edition). Harlow: Pearson Education Limited; 2018.

[9] Alliance for Wireless Power Rezenca [online]. URL: <http://www.rezenca.com/> Accessed 15 November 2019.

[10] Niranjana Pathare. A global wireless power standard will open the market, encourage consumers to live without power cords. White Paper [online]. Texas Instruments, 2016. URL: <http://www.ti.com/lit/wp/slyy036/slyy036.pdf> Accessed 15 November 2019.

[11] Grajski, K.A.; Qualcomm Inc., San Diego, CA, USA; Tseng, R.; Wheatley, C. Loosely-coupled wireless power transfer: Physics, circuits, standards [online]. Microwave Workshop Series on Innovative Wireless Power Transmission: Technologies, Systems, and Applications (IMWS), 2012 IEEE MTT-S International; 10-11 May 2012, 9-14. URL:<http://ieeexplore.ieee.org.ezproxy.metropolia.fi/stamp/stamp.jsp?tp=&arnumber=6215828> Accessed 15 November 2019.

[12] Mark Estabrook. The convenience of wireless charging: It's just physics. White paper [online]. MediaTek, 2013. URL: [http://cdn-cw.mediatek.com/Mediatek\\_Wireless\\_Charging.pdf](http://cdn-cw.mediatek.com/Mediatek_Wireless_Charging.pdf) Accessed 30 August 2014.

[13] Mandipjung sibakoti & joey Hambleton (2011, December) wireless power Transmission using magnetic resonance [online]available: [http://www.cornellcollege.edu/physics&\\_engineering\\_/pdfs/phy-312/mandipsibakoti.pdf](http://www.cornellcollege.edu/physics&_engineering_/pdfs/phy-312/mandipsibakoti.pdf)

[14] Daniel Teninty P.E (2015, November 2) wireless power consortium.

[15] vladislav khayradinov 'Wireless Power Transfer System Development & Implementation. 'Dept Electron Eng., Helsinki Metropolia University of Applied Sciences, Helsinki, Finland, 2015'.

[16] [www.sciencedirect.com](http://www.sciencedirect.com) {standards for WPT}

[17] Cincinnati Technical Center. Electromagnetic radiation and how it affects your instruments [online]. Occupational Safety & Health Administration. Cincinnati, Ohio; May 20, 2014. URL: [https://www.osha.gov/SLTC/radiofrequencyradiation/electromagnetic\\_fieldmemo/electromagnetic.html#section\\_6](https://www.osha.gov/SLTC/radiofrequencyradiation/electromagnetic_fieldmemo/electromagnetic.html#section_6) Accessed 13 November 2019.