

**DESIGN AND CONSTRUCTION OF MICROCONTROLLER BASED
VEHICLE SPEED SYSTEM**

BY

BAYODE KEHINDE AYOKUNLE

ENG1805473

OF

DEPARTMENT OF ELECTRICAL/ELECTRONIC ENGINEERING

FACULTY OF ENGINEERING

UNIVERSITY OF BENIN

UGBOWO CAMPUS

EDO STATE

BENIN CITY

APRIL 2024

DESIGN AND CONSTRUCTION OF MICROCONTROLLER BASED

VEHICLE SPEED SYSTEM

BY

BAYODE KEHINDE AYOKUNLE

ENG1805473

**BEING A PROJECT REPORT SUBMITTED TO THE DEPARTMENT OF ELECTRICAL/ELECTRONIC
ENGINEERING IN PARTIAL FULFILMENT OF THE REQUIREMENT FOR THE AWARD OF B.ENG
DEGREE**

FACULTY OF ENGINEERING

UNIBERSITY OF BENIN

EDO STATE

BENIN CITY

APRIL 2024

CERTIFICATION

THIS IS TO CERTIFY THAT THIS PROJECT WAS CARRIED OUT BY ME BAYODE KEHINDE AYOKUNLE OF THE DEPARTMENT OF ELECTRICAL/ELECTRONIC ENGINEERING, UNIVERSITY OF BENIN, EDO STATE, NIGERIA.

.....

Engr. G.O IMHABEKHAI
(Project supervisor)

.....

Date

.....

PROF. K.O OGBEIDE
(HOD)

.....

Date

DEDICATION

This project is dedicated to Almighty God and to my parents Mr and Mrs Bayode and to my entire family at large for their ever loving kindness and support which have seen me through my years of studies.

ACKNOWLEDGEMENT

Firstly, I would like to give my foremost appreciation to God Almighty for the gift of life. Also, for giving me the opportunity to be admitted into the prestigious University of Benin. I want to express my profound gratitude to my lovely parents for their continuous support and show of love.

I want to also thank my brother, Engr. Blessing Bayode who has always been there from the start of this academic journey to render both financial support and guidance to make this journey easy. I will also like to thank my other siblings Ayomide, Sayo and Taiwo Bayode for their support all through my undergraduate journey.

I also will remain grateful to the tremendous contribution of my lecturers Prof. Ogujor (the Dean of Engineering Faculty), Prof. Ogbeide (Head of Electrical Electronic Engineering Department), Engr. Imhabekhai (My project supervisor), and all the staff of Electrical/Electronic Engineering both academic and non-academic staff for their intellectual contribution.

TABLE OF CONTENTS

CERTIFICATION	ii
DECLARATION	iii
ACKNOWLEDGEMENT	iv
TABLE OF CONTENT	v
LISTS OF FIGURE	ix
ACRONYMS	x
ABSTRACT	xi
CHAPTER ONE	1
INTRODUCTION	1
1.0 BACKGROUND OF THE STUDY.....	1
1.1 PROBLEM STATEMENT	2
1.2 AIM	3
1.3 OBJECTIVES	3
1.4 METHODOLOGY	3
1.4.1 METHOD 1	3
1.4.2 METHOD 2	3
1.4.3 METHOD 3	4
1.5 RELEVANCE OF WORK	5
CHAPTER TWO	6
LITERATURE REVIEW	6

2.1 REVIEW OF OTHER RELATED WORK	6
2.2 REVIEW OF INDIVIDUAL COMPONENT	8
2.2.1 SPEEDOMETER	8
2.2.2 VOLTAGE REGULATOR	10
2.2.3 RESISTOR	12
2.2.4 THE OPT COUPLER	13
2.2.5 LIGHT EMTTING DIODE	14
2.2.6 UNIT POTIENTOMETER	14
2.2.7 BUZZER	16
2.2.8 ARDUINO UNO.....	16
2.2.9 HALL EFFECT MODULE	18
2.2.10 OLED DISPLAY	19
2.2.10 ENCLOSURE	21
CHAPTER THREE	22
DESIGN	22
3.0 INTRODUCTION.....	22
3.1 DESIGN SPECIFICATION.....	23
3.2 DESIGN AND ANALYSIS	23
3.2.1 POWER SUPPLY UNIT.....	23
3.2.1.1 FILTERING CAPACITOR	24
3.2.1.2 POTIENTOMETER CIRCUIT	24

3.2.2 THE ROTATING FAN UNIT.....	26
3.2.3 SPEED DETECTING ELEMENT.....	27
3.2.3.1 THE HALL EFFECT MODULE	27
3.2.3.2 THE OPT-COUPLERMODULE	27
3.2.4 THE DISPLAY UNIT	29
3.2.5 THE MICRO- CONTROLLER UNIT	31
3.2.5 THE BUZZER UNIT	33
3.3 SOFTWARE DESIGN	35
3.4 PRINCINPLE OF OPERATION OF THE WHOLE SYSTEM.....	38
CHAPTER FOUR	39
CONSTRUCTION, TESTING AND RESULT	39
4.0 INTRODUCTION	39
4.1 CONSTRUCTION	39
4.1.1 COMPONENT PROCUREMENT	39
4.1.2 WORK PLANNING	39
4.1.3 TESTING OF INDIVIDUAL COMPONENT	39
4.1.4 COMPONENTS PLACEMENT AND INSTALLATION	40
4.1.5 JOINING OPERATION AND CONNECTION.....	40
4.1.6 ENCLOSURE DESIGN	40
4.2 TESTING	42
4.3 RESULT	42

4.4 BILL OF ENGINEERING MEASUREMEMT	42
CHAPTER FIVE	44
CONCLUSION AND RECOMMENDATION	44
5.0 INTRODUCTION	44
5.1 PROBLEM ENCOUNTERED AND SOLUTION.....	44
5.2 CONCLUSION	44
5.3 RECOMMENDATION	45
REFERENCES	47
APPENDIX	48

LISTS OF FIGURE

Figure 1.1	page 1
Figure 2.1	page 11
Figure 2.2	page 12
Figure 2.3	page 14
Figure 2.4	page 15
Figure 2.5	page 16
Figure 2.6	page 18
Figure 2.7	page 18
Figure 2.8	page 20
Figure 2.9	page 21
Figure 2.10	page 23
Figure 3.1	page 24
Figure 3.2	page 28
Figure 3.3	page 29
Figure 3.4	page 31
Figure 3.5	page 32
Figure 3.6	page 36
Figure 4.1	page 41
Figure 4.2	page 41

ACRONYMS

AC	–	Alternating Current
ADC	–	Analog to digital converter
DC	–	Direct Current
LED	–	Light Emitting Diode
OLED	–	Organic Light Emitting Diode

ABSTRACT

This project revolves around crafting a Microcontroller Vehicle Speed Alarm System engineered to autonomously signal drivers upon exceeding predetermined speed thresholds. The system instantaneously triggers a panic alarm when the vehicle surpasses the defined speed limit, disengaging the alarm once the speed falls below the set threshold. Leveraging the voltage output from a speedometer system, the alarm activation timing is calibrated.

The process involves designing and implementing a vehicle speed alarm after wide study and proper sensor selection, integrating a microcontroller for real-time monitoring of the vehicle speed and triggering of alarm using Arduino-uno programmed with C programming language and providing user-friendly features for drivers. The project and its individual components were also tested at every stage of construction.

This project satisfied the aim of bolstering road safety by employing pre-emptive alerts to drivers, mitigating the risk of accidents resultant from excessive speeding.

CHAPTER ONE

INTRODUCTION

1.0 BACKGROUND OF THE STURDY

In the context of a vehicle's dashboard instrument cluster, an array of vital sensors and gauges serve diverse purposes, from monitoring oil pressure, coolant temperature, and fuel levels to assessing engine performance through the tachometer. However, among these instruments, the speedometer commands unparalleled attention. Its constant visibility while driving renders it a pivotal component, providing real-time indications of a car's speed in miles per hour, kilometers per hour, or both. Despite advancements, modern speedometers, even in late-model vehicles, predominantly remain analog devices employing a needle mechanism to depict speed readings derived from printed numerical values on a dial.



Fig1.1 Motor dashboard with speedometer

The inception of speed measurement in automobiles dates back to the late 19th century. Early speed indicators were rudimentary, often employing mechanical devices such as rotating cables connected to the vehicle's wheels. These devices lacked precision and were prone to inaccuracies. The first significant breakthrough in speedometer technology emerged around the early 1900s. Pioneering companies like Otto Schulze Auto meter

(OSA), later part of Siemens VDO Automotive AG, introduced the first commercially viable speedometers. These early models were mechanical, utilizing a cable-driven system connected to the vehicle's transmission.

The relentless progression of technology has ushered in an era marked by a burgeoning reliance on vehicles, presenting a concomitant rise in challenges associated with road safety. Amidst these concerns, one prevailing issue that significantly contributes to vehicular accidents is the pervasive problem of over-speeding. In response to this critical challenge, our proposed solution advocates for the implementation of a Microcontroller-Based Vehicle Speed Alarm system. This innovative system seeks to proactively engage by promptly alerting drivers when they surpass designated speed limits. By instigating timely notifications, this initiative endeavours to install and reinforce safer driving practices, consequently curbing the alarming frequency of accidents on our roads.

Within this project report, focus centers on the historical evolution of speedometers, elucidating their operational mechanisms, and exploring their digital transformation. Emphasis extends to augmenting speedometers with add-on speed checking functionalities. Furthermore, the discourse delves into prospective trajectories, envisioning potential future designs for speedometers. Accompanying these discussions is a pictorial representation offering an overview of a standard speedometer configuration.

1.1 PROBLEM STATEMENT

Over speeding remains a prevalent issue, leading to a high number of accidents and loss of lives. The project aims to address the prevalent issue of over-speeding in vehicles by designing and implementing a specialized microcontroller-based speed alarm system. Despite the persistence of accidents and loss of lives due to speeding, conventional speed limit signs and existing speed alarm systems have proven inadequate. Therefore, this project endeavours to construct a microcontroller-driven speed alarm tailored to effectively alert drivers when exceeding safe speed limits, ultimately enhancing road safety and reducing the risks associated with over-speeding incidents.

1.2 AIM

The aim of this project work is to design, construct and build a microcontroller based vehicle speed alarm system

1.3 OBJECTIVES

The specific objectives of this project are as follow:

- I. To design and implement a Microcontroller-Based Vehicle Speed Alarm system.
- II. To construct a system that would accurately detect vehicle speed and provide real-time alerts to drivers.
- III. To design a system that will ensure driver's compliance with speed limits and road safety rule.

1.4 METHODOLOGY

- A microcontroller unit is used to monitor the rotor's speed in real-time. An array of sensors was employed to collect data, which were processed and compared with predefined speed limits (set point). The speed of the rotor was varied by using a potentiometer to vary the resistance that flows through the rotor. When the rotor exceeds the set-point speed, the microcontroller sent an on signal to the alarm system, alerting the driver to slow down. The system was designed to automatically off the alarm when the speed of the rotor is back in allowed limits.
- The construction of Microcontroller-Based Vehicle Speed Alarm system included several steps like:
 - Sensor Selection and Integration: Appropriate sensors (such as Hall effect sensors or GPS modules) capable of accurately measuring vehicle speed was chosen.
 - Microcontroller Programming: Developed embedded software using programming languages like C or C++ to interface with the sensors, process speed data, and compare it with the predefined speed limits. Algorithms were implemented to ensure accurate speed calculations and establish thresholds for triggering the alarm.

Hardware Prototyping: Built a prototype circuit board integrating the microcontroller, sensors, and alarm components. Rigorous test was conducted to validate the hardware design, ensure accurate speed detection and reliable alarm activation.

Performance Evaluation: Comprehensive performance tests was conducted, including speed accuracy, alarm responsiveness, and power consumption analysis. The system's performance was evaluated under diverse driving conditions, such as varying speeds, terrains, and weather conditions, to validate its reliability and effectiveness.

This technical methodology was followed for the development of the Microcontroller-Based Vehicle Speed Alarm system to be systematic, rigorous, and focused on delivering a reliable and efficient solution to address the problem of over speeding effectively.

- The system was designed with suitable alarm system components like speakers or buzzers. The alarm triggers were configured based on speed threshold values. Implemented circuitry to produce loud and distinct alerts, ensuring they are clearly audible to the driver even in noisy environments. The design used an OLED display screen to display a visible current speed to the driver. All these would ensure driver's compliance with speed limits and ensure road safety.

1.5 RELEVANCE OF WORK

The Microcontroller-Based Vehicle Speed Alarm system will address the issue of over speeding by providing immediate, audible alerts to drivers when they exceed the speed limits. By promoting responsible driving behaviour, the system will significantly reduce the occurrence of accidents caused by over speeding, thereby saving lives and reducing property damage.

CHAPTER TWO

LITERATURE REVIEW

2.1 REVIEW OF OTHER RELATED WORK

The rising rate of vehicle road accidents has led to a dynamic and rising industry of car protection and alert systems. In an attempt to lower the number of car accidents on the road, a number of noteworthy innovations have been developed and tested. Many of these studies offer insightful information about the functioning and operations of microcontrollers for vehicle protection, and this chapter will skim the surface of a few earlier studies that share this kind of information.

A significant study in the realm of vehicle speed alarm systems was conducted by Mark Johnson (2018) in his paper titled "Development of a Wireless Vehicle Speed Alarm System." Johnson's research delved into the design and implementation of a wireless speed alarm system that utilizes Doppler radar technology to detect vehicle speed. The system is equipped with an alarm mechanism that alerts drivers when they exceed pre-set speed limits. Through the integration of microcontroller technology and wireless communication modules, Johnson's system offers real-time monitoring and notification capabilities to enhance road safety. This research contributes valuable insights into the development of efficient and effective speed monitoring solutions for vehicles.

Another noteworthy investigation in the field of vehicle speed alarm systems was undertaken by Emily Chen (2020) in her study titled "Smartphone-Based Speed Alert System for Safe Driving." Chen's research focuses on leveraging the ubiquitous presence of smartphones to develop a cost-effective speed alert system. The system utilizes the smartphone's built-in GPS and accelerometer sensors to monitor vehicle speed and driving behaviour in real-time. When the vehicle exceeds predefined speed thresholds, the system triggers visual and auditory alerts on the smartphone interface to notify the driver. Additionally, Chen's system offers features such as trip logging and speed trend analysis to promote safe

driving habits and improve overall road safety. This research highlights the potential of smartphone technology in creating innovative solutions for vehicle speed monitoring and alerting.

Research conducted by Sarah Lee (2017) titled "Development of an Intelligent Vehicle Speed Alarm System Using Machine Learning Techniques." Lee's study focuses on the integration of machine learning algorithms with vehicle speed monitoring systems to enhance their intelligence and accuracy. By analyzing historical speed data and driver behavior patterns, the system can predict potential speeding incidents and issue timely alerts to drivers. Lee's research showcases the effectiveness of machine learning in improving the proactive capabilities of speed alarm systems, thereby contributing to the prevention of road accidents and fatalities.

Another significant research endeavour in this domain is the work by David Smith (2019) titled "Real-Time Vehicle Speed Monitoring and Alert System Using Computer Vision." Smith's research explores the application of computer vision techniques for real-time vehicle speed monitoring and alerting. By deploying cameras along roadways, the system captures video footage of passing vehicles and utilizes image processing algorithms to estimate their speeds. When a vehicle exceeds the speed limit, the system triggers instant alerts to nearby authorities or drivers via connected devices. Smith's study demonstrates the feasibility and effectiveness of computer vision-based solutions in augmenting traditional speed monitoring methods, offering potential advantages in terms of scalability and cost-efficiency.

Research conducted by Michael Wang (2021) titled "Development of a Smart Vehicle Speed Alarm System Using Internet of Things (IoT) Technology." Wang's study focuses on leveraging IoT technology to create an intelligent speed alarm system for vehicles. By integrating sensors, microcontrollers, and wireless communication modules, the system continuously monitors vehicle speed and road conditions in real-time. Using cloud-based data processing and analysis, the system can dynamically adjust speed thresholds based on factors such as weather, traffic congestion, and road conditions. Moreover, the system can issue personalized alerts to drivers via smartphone applications, promoting safer driving habits and reducing the risk of accidents.

Wang's research highlights the potential of IoT-enabled solutions in enhancing road safety through advanced speed monitoring and alerting capabilities.

This project combines real-time monitoring and feedback, intruder detection and alarm, and an interactive user interface to contrast and enhance the many concepts put forth and investigated in these publications and research projects.

2.2 REVIEW OF INDIVIDUAL COMPONENT

A project of this magnitude and complexity needs a wide range of components to carry out the different tasks assigned to each component in order for the system to operate as intended and correctly. Each part utilized in the creation of the speed alert is described in this section.

2.2.1 SPEEDOMETERS

A speedometer is a device that shows a car's speed; it is typically used in conjunction with an odometer, which tracks distance travelled. Although the electric speedometer is claimed to Croatian inventor Josip Belušić in 1888, British inventor Charles Babbage produced an early variant suited for locomotives.

The speedometers of today are often electronic. A rotating sensor installed in the transmission produces a sequence of electronic pulses whose frequency relates to the driveshaft's (average) rotational speed and, in turn, the vehicle's speed, presuming all four wheels have full traction, in designs that are developed from previous eddy-current versions. The sensor is usually a toothed metal disk placed between a magnet and a magnetic field sensor, or a set of one or more magnets mounted on the output shaft or differential crown wheel (in transaxles). The magnets or teeth pass beneath the sensor as it rotates, affecting the strength of the magnetic

field the sensor is measuring and causing a pulse to be recorded each time. As an alternative, several manufacturers now use pulses from the ABS wheel sensors in their more current designs.

An additional early type of electronic speedometer depends on a mechanical pulse powered by the car's wheel or transmission interacting with a precision watch mechanism. The speedometer pointer is pushed toward zero by the watch mechanism and toward infinity by the vehicle's pulse. The respective magnitudes of the two systems' outputs are reflected in the speedometer pointer's position. The induced voltage that results from applying the hall-effect approach is transformed to digital utilizing the analog to digital conversion technique, as demonstrated in the above image.

The principle of operation of a traditional mechanical speedometer involves a flexible, spinning metal cable that connects to the vehicle's transmission. As the vehicle moves, the spinning motion of the cable is transferred to the speedometer. Inside the speedometer, the cable connects to a magnet, which is mounted on a needle. The magnet rotates in proportion to the speed of the vehicle, causing the needle to move across the dial and indicate the speed.

On the other hand, modern electronic speedometers often use the Hall effect for their operation. The Hall effect is a physics phenomenon discovered by Edwin Hall in 1879, and it involves the generation of a voltage difference (Hall voltage) perpendicular to the flow of electric current in a conductor when exposed to a magnetic field.

Here's how the Hall effect is applied in a speedometer:

- **Sensor Placement:** A small Hall effect sensor is strategically placed in close proximity to a rotating component within the vehicle, such as the driveshaft or a wheel.
- **Magnetic Field Interaction:** As the rotating component moves, it generates a changing magnetic field. This magnetic field interacts with the Hall effect sensor.

- **Voltage Generation:** The Hall effect sensor produces a voltage signal proportional to the strength of the magnetic field it encounters. The faster the rotation, the stronger the magnetic field, resulting in a higher voltage output.
- **Electronic Processing:** The voltage signal generated by the Hall effect sensor is then processed by electronic circuits within the speedometer.
- **Speed Display:** The processed signal is translated into a speed reading, and this information is displayed on the speedometer dial, providing the driver with real-time speed information.

Using the Hall effect for speed sensing offers advantages such as accuracy, reliability, and the ability to integrate with electronic control systems in modern vehicles. It's a more precise and responsive method compared to the mechanical cable-driven systems, making it a popular choice in contemporary automotive technology. The function of a variety of electric meters and measuring instruments, such as ammeters, wattmeter's, magnetic compasses, and position sensing devices, as well as power-transforming solid-state devices known as transducers, are based on the *Hall Effect*.

2.2.2 VOLTAGE REGULATOR

A voltage regulator is an electronic device or circuit that maintains a constant output voltage regardless of changes in input voltage, load current, or temperature. Its primary function is to stabilize the voltage supplied to electrical devices or systems, ensuring that they receive a consistent and reliable voltage level.

There are various types of voltage regulators, but two common categories are linear voltage regulators and switching voltage regulators.

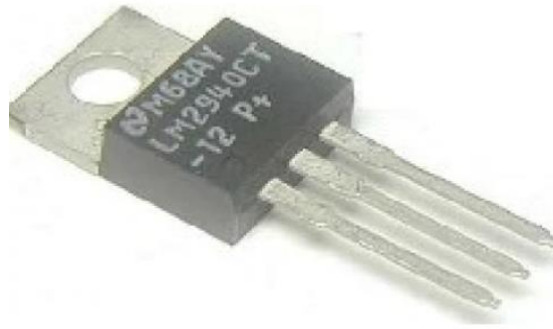

Fig2.1 a LM2940 voltage regulator

A Voltage Regulator, often referred to simply as a "regulator," features a seemingly straightforward three-legged design, yet beneath its apparent simplicity lies a sophisticated integrated circuit. This device plays a crucial role in transforming fluctuating input voltages into a consistent and regulated output voltage. Voltage regulators come in diverse output configurations, commonly providing stable outputs such as 5 volts, 9 volts, and 12 volts. The concluding digits in the nomenclature signify the specific output voltage.

A voltage regulator, like the LM7805, is added to the circuit to achieve the required 5-volt level needed to power the microcontroller after rectification, where the positive end achieves the full 15 volts. A regulated power supply is ensured by the LM7805 voltage regulator, which guarantees that only 5 volts are sent downstream. As a result, the system may run smoothly at voltage levels of +5 volts, +15 volts, and 0 volts thanks to this power supply design.

2.2.3 RESISTOR

Resistors are fundamental components in electronic circuits, serving to limit current flow, divide voltage, and perform other essential functions. Their resistance, measured in ohms (Ω), determines the extent to which they impede the flow of electric current. The colour code system is a widely used method to denote the resistance value of resistors, making it easier for engineers, technicians, and hobbyists to identify and use them accurately in circuits.



Fig2.2 a Resistor and a resistor symbol

The colour code system employs coloured bands or stripes on the surface of the resistor to represent its resistance value and tolerance. These bands are typically found on cylindrical resistors, with each band corresponding to a specific digit or multiplier in the resistor's resistance value. Understanding how to interpret these bands allows one to determine the resistance of a resistor at a glance.

The colour bands on a resistor usually consist of four or five bands, with each colour representing a numerical value according to the following scheme:

1. **First Band (1st Digit):** This band represents the first digit of the resistance value. Each colour corresponds to a specific digit from 0 to 9.
2. **Second Band (2nd Digit):** Similar to the first band, this band represents the second digit of the resistance value.

3. **Multiplier Band (Multiplier):** This band denotes the multiplier or power of 10 by which the first two digits should be multiplied to obtain the resistance value. Common multiplier values include 1 (no band), 10, 100, 1,000, etc.
4. **Tolerance Band (Tolerance):** The tolerance band indicates the tolerance or permissible deviation from the stated resistance value. It represents the percentage by which the actual resistance can deviate from the nominal value. Common tolerance values include $\pm 1\%$, $\pm 5\%$, $\pm 10\%$, etc.

2.2.4 THE OPT COUPLER

An opt-isolator, sometimes referred to as an opt coupler, photo coupler, or optical isolator, is a type of electronic device used to transfer electrical signals between its input and output by means of light waves. Its main goal is to protect circuitry and avoid transmission distortion by limiting the impact of high voltages or abrupt voltage changes on one side of the circuit on the other. Current market-available opt-isolators are capable of withstanding input-to-output voltages of up to 10 kV and managing voltage transients at up to 10 kV/ μ s.

An opt coupler is a device that transfers electrical signals optically over an isolation barrier. It has an LED on its input side and a photodetector on its output side. By providing electrical isolation between the input and output sides, this optical transmission protects delicate components from high voltages and possible damage. Opt-coupler-provided galvanic isolation is crucial for preventing ground loops and improving circuit safety. Opt couplers are useful in applications where signal integrity is crucial because they improve noise immunity through the use of light for signal transmission.

2.2.5 LIGHT EMITTING DIODE

When current passes through a light-emitting diode (LED), a semiconductor device, light is released. Photons are released as a result of the semiconductor's electrons and electron holes recombining. The energy needed for electrons to pass the semiconductor's band gap determines the color of the light, which is correlated with photon energy. Using numerous semiconductors or covering the semiconductor device with a coating of light-emitting phosphor allows for the production of white light.

LEDs can be susceptible to heat damage during soldering, although the risk is minimal unless the soldering process is exceptionally slow. Generally, there is no requirement for special precautions when soldering the majority of LEDs.

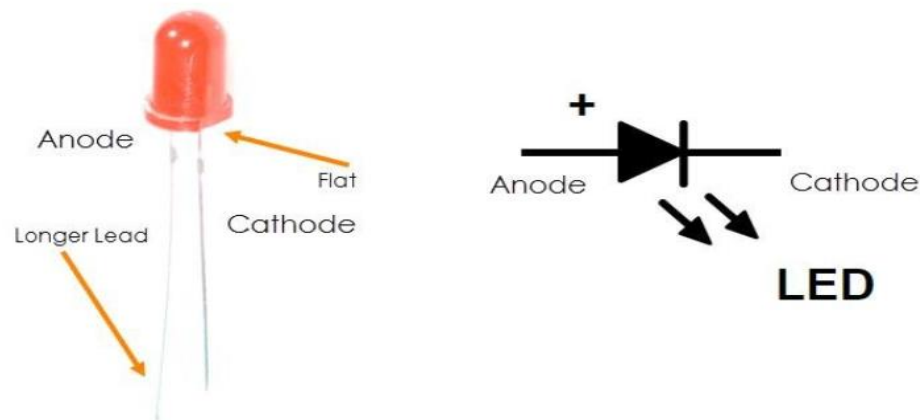

Fig2.3 LED and its symbol

2.2.6 UNIT POTENTIOMETER

A unit potentiometer, also called a "unit pot," is a linearly tapered, single-turn potentiometer. It is employed in general-purpose applications where a basic voltage divider or variable resistor is required, and its resistance is usually 1 kilohm. Unit potentiometers are frequently used in instrumentation circuits for signal modification or in audio equipment for volume control.

They provide a straightforward and cost-effective solution for fine-tuning electrical signals within a circuit. In the realm of circuit theory and measurement, a potentiometer acts as a voltage divider, essential for gauging electric potential (voltage). Its operation embodies this fundamental principle, hence the straightforward name. Potentiometers are ubiquitous in the realm of controlling electrical devices, serving as the silent conductors behind volume adjustments in audio equipment. Furthermore, potentiometers with mechanical controls can seamlessly transition into position transducers, integral components of joysticks and similar devices. When it comes to handling power, potentiometers tread cautiously, typically shying away from directly managing substantial wattage. This reluctance stems from the risk of power dissipation within the potentiometer approaching levels comparable to the power in the load it's meant to regulate, as witnessed with infinite switches. Instead, their forte lies in fine-tuning analogue signal levels, such as adjusting volume in audio setups, and acting as reliable control inputs for electronic circuits. Take, for instance, the humble light dimmer, a quintessential application where a potentiometer orchestrates the precise modulation of lamp brightness by delicately managing the switching of a TRIAC. Thus, indirectly, potentiometers influence the ambiance of spaces with a gentle flick of a switch.



Fig2.4 a unit potentiometer

2.2.7 BUZZER

A buzzer is an electro-acoustic device that produces sound when an electric current is passed through it. It typically consists of a coil of wire wrapped around a magnetic core, a diaphragm or a small metal disc, and a housing to amplify the sound. When an electrical signal is applied to the coil, it creates a magnetic field that attracts or repels the diaphragm, causing it to vibrate and produce sound waves. Buzzer sound frequencies can vary depending on their design and application, ranging from high-pitched tones to low-frequency buzzes. Buzzers are commonly used in various electronic devices such as alarm systems, timers, doorbells, and electronic games to provide audible alerts or notifications. They are simple, reliable, and cost-effective components for generating sound in a wide range of applications.



Fig2.5 a buzzer

In the speed alarm circuit, a buzzer serves as an audible warning device. When the vehicle's speed exceeds a preset threshold, the circuit activates the buzzer, alerting the driver to slow down. This provides real-time feedback, encouraging safer driving habits and potentially preventing accidents or speeding violations.

2.2.8 ARDUINO UNO

The Arduino Uno is a microcontroller board based on the ATmega328P chip. It's a popular choice for beginners and experienced makers alike due to its versatility, ease of use, and vast community support. Here's a brief overview of its principle of operation and some basic features:

- **Microcontroller:** The heart of the Arduino Uno is the ATmega328P microcontroller. It runs at 16 MHz and contains a central processing unit (CPU), memory (both flash and SRAM), and various I/O peripherals.
- **Digital and Analog I/O Pins:** The Uno has 14 digital input/output pins, of which 6 can be used as PWM (Pulse Width Modulation) outputs. It also has 6 analog input pins, which can measure voltages between 0 and 5 volts.
- **USB Interface:** The Uno can be programmed and powered via a USB connection to a computer. This allows for easy programming and communication with external devices.
- **Power Options:** The board can be powered via USB, an external power supply, or a battery. It has a built-in voltage regulator to ensure stable operation across a range of input voltages.
- **Programming:** Arduino Uno can be programmed using the Arduino Integrated Development Environment (IDE), which simplifies coding with a user-friendly interface and a vast library of pre-written functions (called sketches).

Incorporating the Arduino Uno into a speed alarm component involves integrating it within the circuitry and programming it to monitor vehicle speed, display the real time speed on the OLED display and activate the alarm when necessary. This entails connecting a speed sensor to the Arduino's input pins, defining a speed threshold within the code, continuously monitoring the sensor input, and activating the alarm (in this case, a buzzer) when the detected speed exceeds the threshold. Additionally, feedback is provided to the user through

visual indicators or other output signals to alert them about the speed violation. By leveraging the Arduino Uno's versatility and programmability, it creates a tailored speed alarm system that promotes safer driving habits.



Fig2.6 an arduino uno component

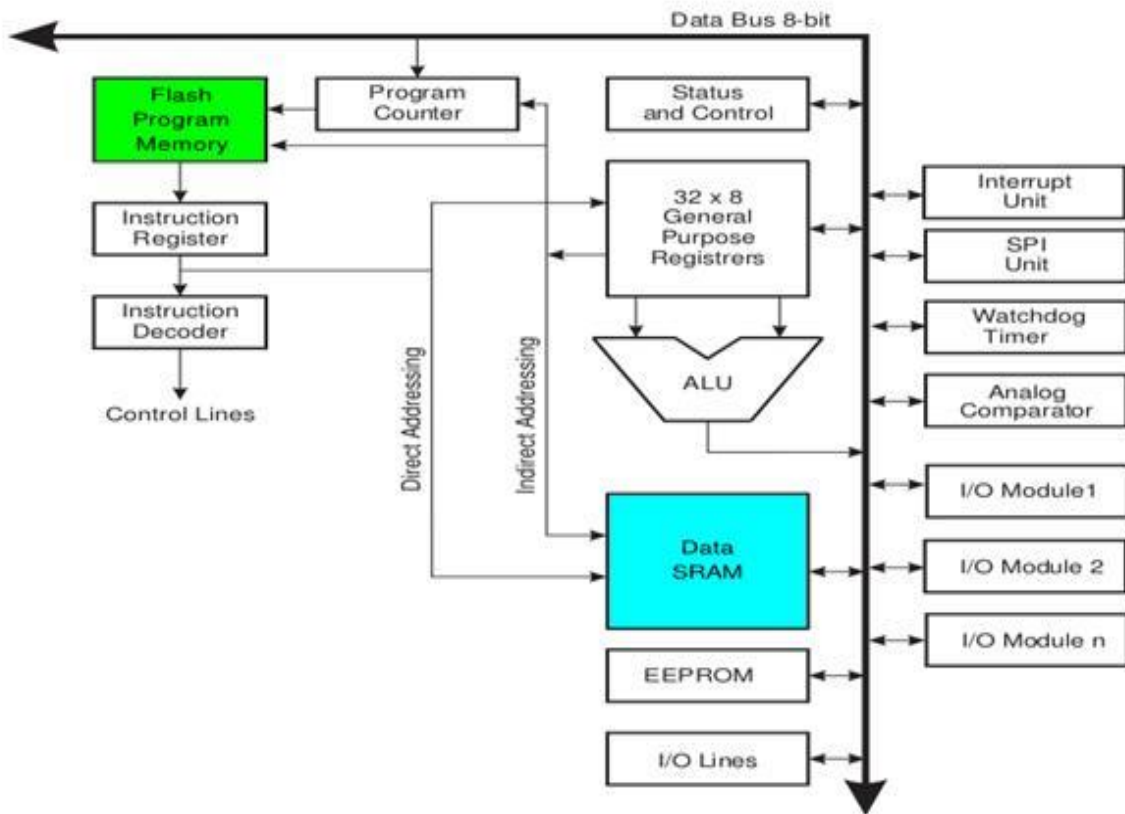

Fig2.7 an arduino uno architecture diagram

2.2.9 HALL EFFECT MODULE

An instrument called the Hall effect module senses the existence of magnetic fields. This module works on the principle of the Hall effect, named for physicist Edwin Hall, who made the discovery in 1879. The Hall effect is the phenomenon where a voltage difference (called Hall voltage) is generated across a conductor or semiconductor when it is exposed to a magnetic field perpendicular to the current flow.

The principle of operation of a Hall effect module involves the following steps:

- **Sensing Element:** The Hall effect module contains a sensing element typically made of semiconductor material, such as gallium arsenide or indium antimonite. This sensing element is usually a thin strip through which a current flow.
- **Applied Magnetic Field:** When a magnetic field is applied perpendicular to the direction of the current flow in the sensing element, it exerts a force on the moving charge carriers (electrons or holes). This force creates a measurable potential difference perpendicular to both the current and the magnetic field, known as the Hall voltage.
- **Output Signal:** The Hall voltage generated is proportional to the strength of the magnetic field. This voltage can be measured using appropriate circuitry connected to the Hall effect module's output pins.
- **Direction Sensitivity:** The polarity of the Hall voltage depends on the orientation of the magnetic field relative to the current flow. By analyzing the polarity of the output voltage, the direction of the magnetic field can be determined.
- **Amplification and Processing:** In practical applications, the raw Hall voltage signal may be weak and susceptible to noise. Therefore, the signal is often amplified and processed using additional circuitry to improve accuracy and reliability.



Fig2.8 an hall effect module

Incorporating a Hall effect module into a speed alarm component involves strategically placing it near a rotating component, such as a wheel or gear shaft, equipped with a magnet. As the magnet passes by the sensor, it generates a magnetic field, inducing a Hall voltage in the sensor. This voltage, proportional to the speed of the rotating component, is then processed, typically through amplification and conditioning, to ensure accuracy. The microcontroller, like an Arduino Uno, can interpret this signal to calculate the vehicle's speed. By comparing this speed to a predefined threshold, the microcontroller can trigger an alarm, such as a buzzer, when the speed exceeds the set limit, thereby alerting the driver to reduce speed. This integration provides a reliable method for monitoring vehicle speed and promoting safer driving habits.

2.2.10 OLED DISPLAY

An OLED (Organic Light Emitting Diode) display is a type of display technology that utilizes organic compounds to emit light when an electric current is applied. OLED displays are known for their high contrast ratio, wide viewing angles, and fast response times.

OLED displays function by emitting light when an electric current passes through organic materials sandwiched between two electrodes. These organic materials consist of layers of organic compounds that emit different colors of light (red, green, and blue) when stimulated. By controlling the intensity of the electric current in each pixel, OLED displays can produce a wide range of colors and brightness levels.

Principle of Operation:

- **Organic Layers:** OLED displays typically consist of several layers of organic materials sandwiched between two conductive electrodes, usually made of glass or plastic.
- **Pixel Structure:** Each pixel in an OLED display contains small organic molecules or polymers that emit light when electric current is applied. These organic materials are arranged in red, green, and blue subpixels, allowing for the production of a wide spectrum of colors.
- **Electroluminescence:** When a voltage is applied across the OLED structure, electrons are injected from the cathode (negative electrode) and holes from the anode (positive electrode) into the organic layers. As the electrons and holes recombine within the organic layers, they release energy in the form of photons, resulting in light emission.
- **Control Circuitry:** The intensity of light emitted by each pixel is controlled by the display's control circuitry, which adjusts the voltage applied to each pixel based on the desired brightness and color.

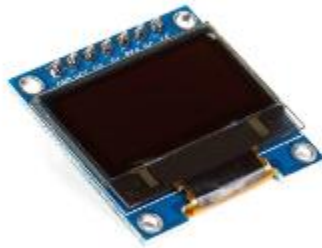

Fig2.9 OLED display board

Incorporating an OLED display with a tachometer in a speed controller component allows for real-time display of vehicle speed. The tachometer sensor to measure the vehicle's speed, such as a Hall effect sensor attached

to the wheel or gear shaft. The microcontroller is interfaced with the OLED display to output the calculated speed. Utilize appropriate display libraries and communication protocols (e.g., I2C or SPI) to send speed data to the OLED display for visualization. The OLED display then present the vehicle's speed accurately and clearly. This include numeric speed readouts, or additional features such as speed units conversion or warning indicators for exceeding speed limits.

By integrating an OLED display with a tachometer, the speed controller component provides drivers with instant feedback on their vehicle's speed, enabling them to maintain safe and efficient driving habits.

2.2.11 ENCLOSURE

An enclosure is a crucial component of the system that gives the inside components general physical protection. The enclosure protects the entire system from environmental elements, physical intrusion, damage, and atmospheric conditions. It also enhances the enclosure's visual appeal by keeping the connections from seeming messy in the open. The most common materials used for enclosures are plastic, metal, waterproof, or custom-made, each with pros and cons of their own.

Selecting an enclosure necessitates meticulous consideration of dimensions and spatial requirements, ease of access, prevailing atmospheric and environmental conditions, adequacy of ventilation, and available mounting alternatives.



Fig2.10 Enclosure

CHAPTER THREE

DESIGN

3.0 INTRODUCTION

This chapter covers extensively the major components that will be used in the circuit design of this project including comprehensive analysis and calculation of the various module and functions of the individual parts that constitute the module and the functions of the part that constitute the design. Design calculations, software development, hardware design and assembly language used.

The project block diagram is shown below for simplicity

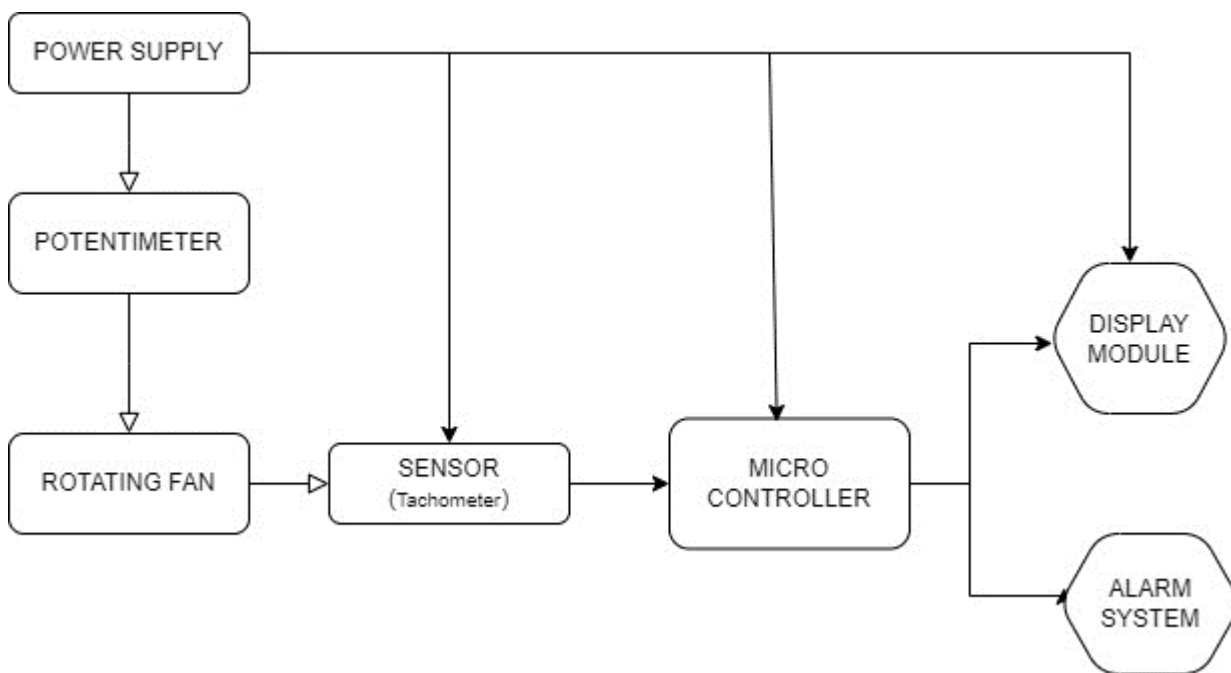

Fig3.1 Project block diagram

The entire system consists of the following units;

- i. The power supply unit
- ii. The rotating fan unit
- iii. Speed detecting element

- iv. The control Unit
- v. The display unit
- vi. Buzzer alarm unit

3.1 DESIGN SPECIFICATION

The vehicle microcontroller speed alarm with rotating fan model consists of the following design specification;

Input voltage 12v DC

Operating frequency: 50HZ

Vehicle model: one 12v rotating fan

Buzzer: 3v-4v

Rotatory potentiometer

OLED display

3.2 DESIGN AND ANALYSIS

3.2.1 POWER SUPPLY UNIT

The power supply unit is built to supply the microcontroller with 5 volts DC and also supply the rotating fan module with varying voltage of 10 to 12 volts DC. The power unit is built around a 12v automotive accumulator (car battery), then a voltage regulator is connected to tailor down the unregulated DC voltage to +5volts dc via voltage regulator (78L05) These serves as the power supply. A decoupling capacitor is connected across the +5v and ground reference of the power to filter or reject the transient noise generated by the microcontroller and associate components in the circuit at run time.

- **Requirement of the Power unit**

- i. Should be able to provide a constant 5v D.C to the microcontroller
- ii. Should be able to provide a constant 12v D.C to the rotating fan
- iii. Ensure reliable operation
- iv. Reject transient noise from the micro controller

3.2.1.1 FILTERING CAPACITOR

The filter capacitor eliminates the ripple content in the D.C output from the voltage regulator before supplying it to the Arduino input.

- **Requirement of the selection of filtering capacitor**

The choice of the capacitor depends on:

- i. Equivalent series resistance (ESR) and equivalent series inductance (ESL)
- ii. Breakdown voltage of the capacitor
- iii. The ripple voltage

- **Calculating the capacitance value of the capacitor**

$$C = \frac{I \times \Delta t}{\Delta V} \dots\dots\dots(i)$$

where I is the load current of 50mA

ΔV is the maximum allowable ripple voltage of 0.1V

Δt is Time period for one cycle of the ripple voltage in seconds

recall $\Delta t = \frac{1}{2f}$ (ii)

where f is the frequency of the ripple voltage

Since we are dealing with rectified A. C voltage from thr voltage regulator,

therefore the ripple frequency is twice the main frequency.

the main frequency = 50 Hz

then ripple frequency $f = 100$ Hz

therefore; $\Delta t = \frac{1}{2 \times 100} = 5ms$

subt in eqn i

$$C = \frac{0.05 \times 0.005}{0.1} = 0.0025 \text{ F} = 2500 \mu\text{F}$$

so a 2500 μF or larger filtering capacitor is required to keep the ripple voltage below 0.1 V and a load current of 0.05A and a ripple frequency of 100Hz.

3.2.1.2 POTENTIOMETER MODULE

The potentiometer, consisting of a constantan wire and a fixed resistance, forms a voltage divider. Voltage across the constantan wire varies proportionally with its length due to the wire's resistance changing accordingly.

In this design, the potentiometer is used in controlling the speed of a fan representing a moving vehicle, the potentiometer serves to adjust the fan speed to mimic variable vehicle speeds. By modifying the length of the constantan wire through the potentiometer, the voltage across the wire is adjusted, thus altering the power sent to the fan. This enables the emulation of various vehicle speeds for testing and model validation purposes.

The output voltage sent to the fan $V_{out} = V_{in} \frac{R_2}{R_1 + R_2}$ (iii)

Where; R_2 is the resistance from the fixed resistor = 1000Ω

R_1 is the variable resistance from the potentiometer

Input voltage V_{in} range 11 – 14v (due to variation)

Output voltage for the rotating fan V_{out} range $V_{max} = 12v DC$; $V_{min} = 10v D.c$

The output voltage supplied to the rotating fan is varied by the potentiometer within the range of (10 to 12)v D.C ensuring consistent and reliable power for the speed control mechanism. Integrating the potentiometer into the system facilitates the adjustment of the fan speed, enabling realistic simulation of variable vehicle speeds to assess the model's performance under different operating conditions.

3.2.2 THE ROTATING FAN UNIT

A rotating fan unit is often used to replicate the sensation of a moving vehicle in simulations or virtual reality experiences. This device typically consists of a fan mounted on a rotating base. A magnet is attached to one of the blade of the fan. Which help to measure the speed of the rotating in revolution per minutes. The rotatory variable potentiometer is used to vary the voltage that flows to the fan.

Which then varies the speed of the fan. Since the voltage varies directly with speed

$$e_b \propto \frac{Ns}{\phi} \text{ (iv)}$$

Where Ns is the speed of the fan in rpm

ϕ is magnetic flux in weber

This is used to test the component module as to be use in a vehicle

3.2.3 SPEED DETECTING ELEMENT

This unit is responsible for measuring of the speed of the rotating fan. It then transmits the speed signal to the micro-controller. It consists of the tachometer, opt coupler, and Hall effect module work. They work together to accurately measure and monitor the rotational speed the rotating fan. As the speed of the fan varies they measure and send the signal to the micro-controller (Arduino Uno).

- **Requirement of the Sensor unit**
 - i. Should be able to detect and measure speed accurately
 - ii. Easy principle of operation
 - iii. Availability and cost effectiveness

3.2.3.1 THE HALL EFFECT MODULE

Ohm's law describes the relationship between current, voltage, and resistance. The hall effect voltage is applied to the RV1 and U3 LED. The speedometer cable transmits the centrifugal effect to the dynamo. Because changes in an automobile's speed also cause changes in the centrifugal effect, the dynamo's voltage is also affected. According to this law, the voltage across a conductor and the resistance of the conductor are directly and inversely related to the amount of current flowing through them. Ohm's law can be expressed as an equation, $V = IR$, where V is the difference in voltage between two locations (called the potential difference), I is the amount of current in amperes that is flowing in between these two points, and R is the resistance in ohms of the conductor between the two locations of interest. Ohm's law can also be written $R = \frac{V}{I}$ and $I = \frac{V}{R}$.

If any two of the quantities are known, the third can be calculated.. For instance, if the series resistance of the LED is assumed to be 1000Ω and the Hall Effect voltage results in a potential difference of 5 volts, then this equation can be used to calculate the current that passes through the LED,

$$I = \frac{V}{R} \dots\dots\dots(v)$$

$V = 5v$ and $R = 1K \Omega (1000\Omega)$

$5/1000 = 50$ mili-amps neglecting the diode drop.

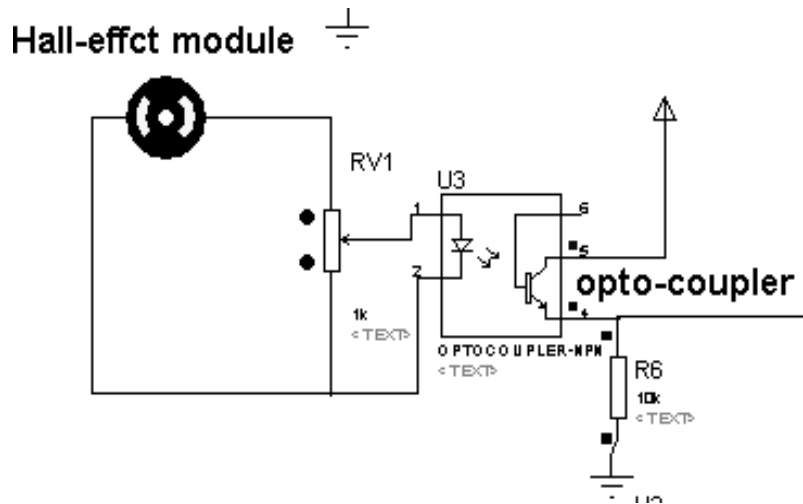

Fig3.2 Hall effect module

3.2.3.2 THE OPT-COUPLER MODULE

The Hall effect sensor detects changes in a magnetic field, typically caused by a rotating gear or magnet. This detection generates an electrical signal, which is transmitted to a microcontroller through the opto-coupler for processing.

The opto-coupler ensures electrical isolation between the Hall effect module and the microcontroller, safeguarding the latter from potential voltage spikes or noise originating from the sensor. This setup enhances system reliability and safety, enabling efficient monitoring and alarm activation based on speed variations detected by the Hall effect sensor.

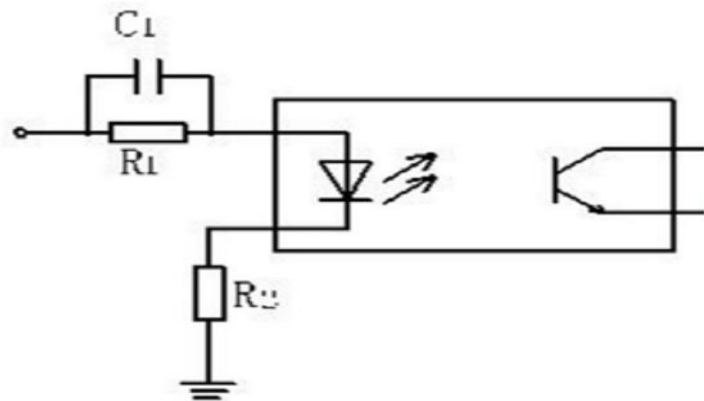

Fig3.3 Opt coupler circuit diagram

3.2.4 THE DISPLAY UNIT

The Display was built around a 128 x 32 OLED display which shows the speed at which the rotating fan (car) is rotating

A. Requirement for selection of the display unit;

- i. Should be large enough to display speed visibly
- ii. Easy to use and interface with circuit
- iii. Cost effectiveness and availability

B. Selection of the Display

OLED display is chosen due to his several advantages over LCD. which are;

- i. Better picture angle
- ii. Wider viewing angle
- iii. Faster response time
- iv. Thinner and lighter
- v. Durability and better color reproduction
- vi. Energy efficiency

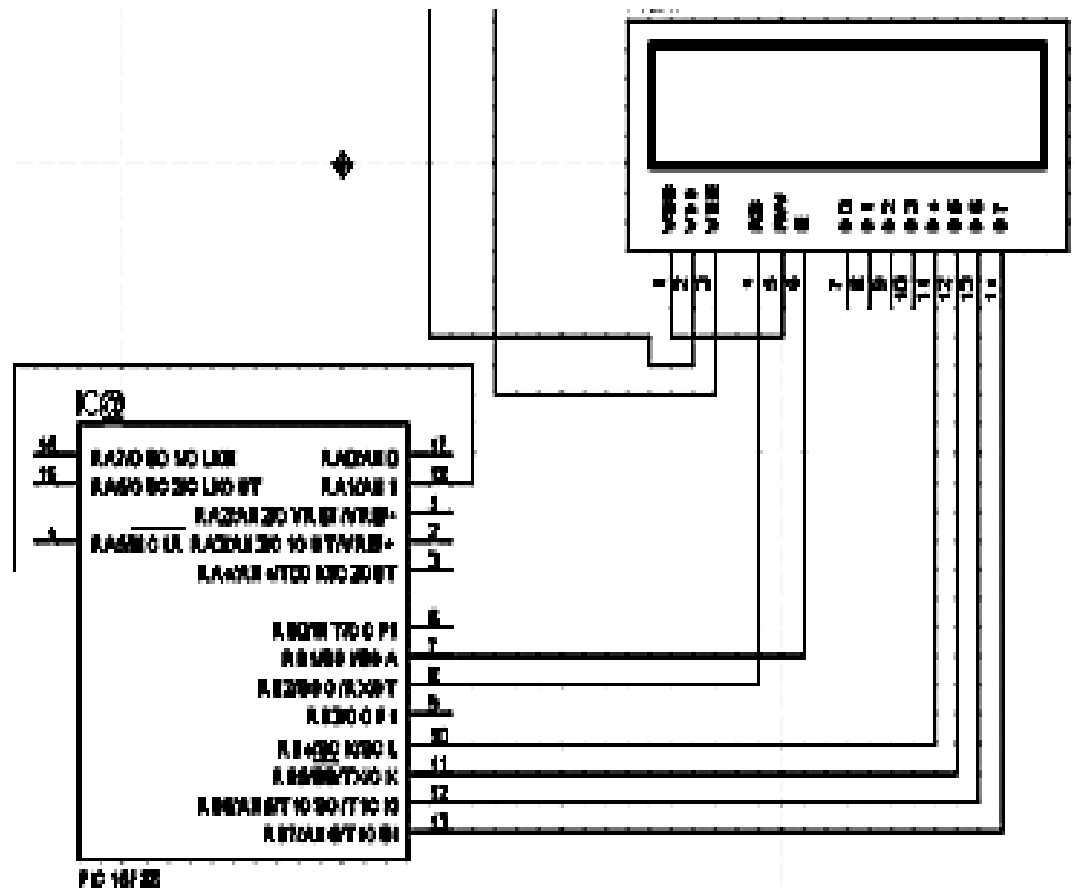

Fig3.4 OLED display Interfaced to the control unit (Arduino Uno)

3.2.5 THE MICRO CONTROLLER UNIT

This unit is the heart of the project it controls the ON-ing and OFF-ing of the buzzer alarm. It is also

responsible for the display of the speed on the display unit (OLED).

A. Brief function of the microcontroller unit

- i. Receives signal from the Tachometer
- ii. It updates the display unit on the actual speed of the rotating fan(Vehicle)
- iii. It ON the buzzer alarm when the vehicle's speed is above the set speed
- iv. It OFF the buzzer alarm when the vehicle's speed is reduced below the set speed

B. Requirement for the selection of the Micro-controller

Below are the requirements for the selection of the controller

The microcontroller must have enough input/output to interface the display unit, the buzzer alarm and the speed sensor (tachometer).

The controller should be available and cost effective

The controller should be easy to be programmed (Software) and also be easily interface with the individual component

C. Selection of The Microcontroller

An Arduino Uno microcontroller is used because of its ease of use, versatility, affordability, compatibility, Expandability and cross platform support.

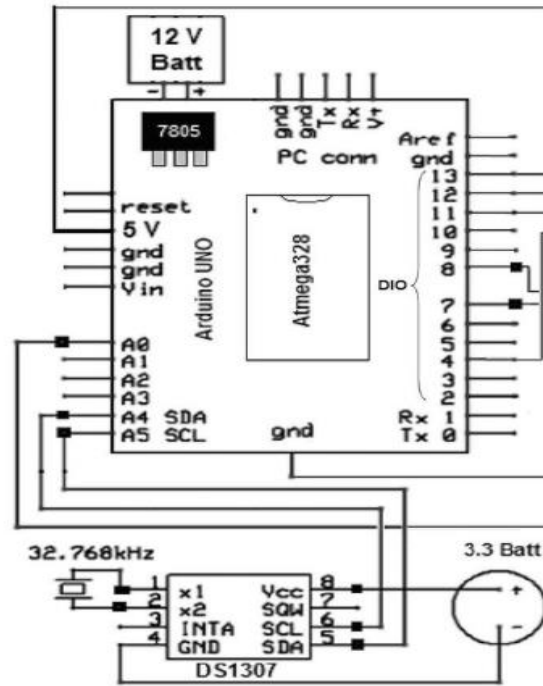

Fig3.5 microcontroller diagram

A software program, typically written in C/C++ language using the Arduino IDE, is developed to generate machine code. This machine code is then uploaded to the flash memory of the microcontroller using the built-in USB interface, a process commonly known as firmware integration.

The reset mechanism of the microcontroller can be configured during design time, allowing the system to reset at power-up. This ensures that the CPU always starts program execution from the system reset vector. The microcontroller typically utilizes an external quartz crystal oscillator for clocking, providing accurate timing for applications.

In summary, when using an Arduino Uno instead of a standalone microcontroller, adjustments are made to the programming language, development environment, flash memory programming

method, reset mechanism, clock source, and pin configuration to effectively leverage the features and capabilities of the Arduino platform.

3.2.6 THE BUZZER UNIT

The buzzer plays a crucial role in alerting individuals through high-frequency audible signals, activated by the microcontroller's detection of vehicle speed surpassing a predetermined threshold. In this project, the buzzer is promptly triggered upon detection, effectively drawing attention to the speeding condition. Furthermore, the microcontroller is programmed to automatically deactivate the buzzer once the vehicle's speed decelerates to a level below the pre-set threshold, ensuring that the alert ceases once the speeding situation is resolved. This integration of real-time detection and automatic control underscores the efficiency and user-friendly nature of the system, contributing to enhanced safety and compliance with speed regulations.

A. Requirement analysis for buzzer selection

- i. Low power consumption
- ii. Audible output
- iii. Automatic deactivation

B. Selection of buzzer alarm

The selection of a buzzer for the vehicle speed alarm system is advantageous for several reasons:

- i. Simplicity; Buzzers offer a straightforward and uncomplicated solution for generating audible alerts.

- ii. Low cost
- iii. Suitability for Generating Loud Alarm Sounds: Buzzers are specifically designed to produce loud and attention-grabbing sounds, making them highly effective for alerting individuals to potential hazards or emergencies.]

- **Calculation of the required voltage rating of the buzzer**

Given:

Audible capacity: 85 dB at 10 cm

Circuit current rating: 50mA (0.05A)

Using the formula for sound pressure level (SPL) in decibels to calculate the required power to achieve the require sound decibel

$$SPL = SPL_0 - 20 \cdot \log_{10} \left(\frac{P}{P_0} \right) \dots\dots\dots(vi)$$

Where:

SPL = Sound pressure level (dB)

SPL_0 = Reference sound pressure level (usually 20 μ Pa)

P = Power level of the sound source (in watts)

P_0 = Reference power level (usually 1 mW)

therefore; $SPL = 85dB, SPL_0 = 20 \mu Pa, P_0 = 1 mW$

Using the formula:

85 dB = 20 · log₁₀ ($\frac{P}{1 \text{ mW}}$), we neglect SPL_0 since its very small

$$\frac{85}{20} = \log_{10} \left(\frac{P}{1 \text{ mW}} \right)$$

$$\log_{10} P = 4.25$$

$$P = 10^{4.25} \text{ mW}$$

$$P = 177.83 \text{ mW}$$

Using the formula $P=V \times I$ (vii)

Where; P is the power rating (in watts),

V is the voltage across the buzzer (in volts),

I is the current consumption of the buzzer (in amperes):

$$\text{Therefore } V = \frac{P}{I} = \frac{177.83 \text{ mW}}{50 \text{ mA}}$$

$$V = 3.5566 \text{ V}$$

So a 4V buzzer is selected to obtain the required audible capacity and circuit power rating, considering the specified circuit current rating.

3.3 SOFTWARE DESIGN

The software design of a microcontroller-based vehicle speed alarm typically involves the following steps:

- i. Initialization
- ii. Speed Sensing

- iii. Threshold Comparison
- iv. Alarm Generation
- v. User Interface
- vi. Interrupt Handling
- vii. Power Management
- viii. Error Handling

Each step plays a crucial role in the overall functionality and reliability of the vehicle speed alarm system.

Flow chart representation of the system;

The system functionality is represented on a flow chart as shown in fig 3.7

Flow chart interpretation

When the car is on the circuit is on and the alarm is initially off, As the car moves the OLED start showing the speed of the vehicle. When vehicle accelerate above set speed, the alarm comes on

After the vehicle is decelerated below the pre-set thresholdt the alarm goes off. As the vehicle come to stop and off, the circuit stops working.

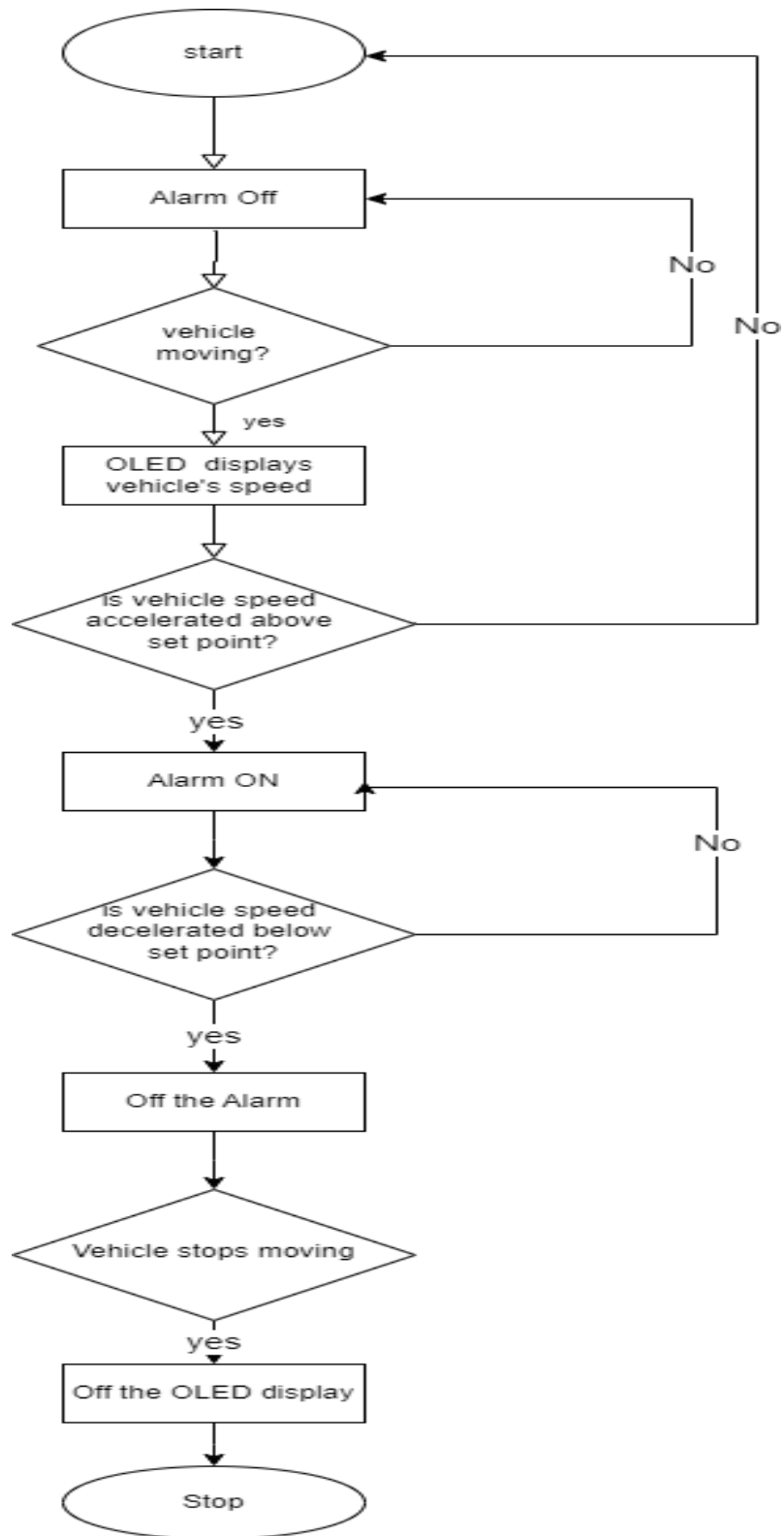

Fig3.6 Project flow chart

3.4 PRINCIPLE OF OPERATION OF THE WHOLE SYSTEM

The system begins with the power supply providing electrical energy to the fan unit and the microcontroller. As the fan unit receives power, it starts rotating, creating airflow to simulate the sensation of a moving vehicle.

Simultaneously, the microcontroller initializes its components, including the analogue-to-digital converter (ADC) module and interface ports. The ADC module reads analogue signals from sensors, such as a speed sensor, which detects the vehicle's speed. The microcontroller then converts these analogue signals into digital values for processing.

Next, the microcontroller compares the vehicle's speed, obtained from the sensor, with a pre-set threshold speed. If the current speed exceeds this threshold, indicating potential over speeding, the microcontroller activates the alarm mechanism. This could involve triggering a buzzer, flashing lights, or activating any other alarm device connected to the microcontroller's output ports.

At the same time, the microcontroller sends the digital speed data to the OLED display module via the interface ports. The OLED display receives this data and presents it visually to the user, showing the current vehicle speed in real-time.

Overall, the system integrates the operation of the fan unit, speed sensing, alarm generation, and speed display on the OLED screen, ensuring a comprehensive solution for monitoring vehicle speed and alerting users to potential safety risks.

CHAPTER FOUR

CONSTRUCTION, TESTING AND RESULT

4.0 INTRODUCTION

This chapter discusses the construction, implementation, testing, results and also the bill of engineering measurement and evaluation

4.1 CONSTRUCTION

4.1.1 COMPONENT PROCUREMENT

The Necessary components for the construction of the project was purchased from the market

4.1.2 WORK PLANNING

The implementation of the project starts with writing of the project proposal which entails the accurate planning of the duration, stages and cost of various parts of the components.

The electronic component was first designed, constructed and tested before I proceeded to coupling of the rotating fan and packaging of the whole components.

4.1.3 TESTING OF INDIVIDUAL COMPONENTS

Components should be tested individually before fiddling with it so as to remove the bad ones. This test will be satisfied test measures for individual components which are basically used of the multi-meter (e.g. testing of transistor, diodes, LEDs are every other component that will be used in the project.

4.1.4 COMPONENTS PLACEMENT AND INSTALLATION

Components are arranged by their functionality so that each component can fall under a particular section on the board with a group functionality. Physical jumper wires were used to connect some stages of the circuit to the next stage of the circuit.

4.1.5 JOINING OPERATION AND CONNECTION

After grouping and testing of individual components. The components are then attached to the board with the help of soldering iron and soldering lead, it was also used for joining jumper wires and components to the board

4.1.6 ENCLOSURE DESIGN

A housing unit was meticulously crafted to safeguard the system components, mirroring the environment within the vehicle. This enclosure was intricately designed to perfectly fit the dimensions of the boards, supplementary platforms, and various components, ensuring a snug and secure arrangement. Additionally, it was engineered to shield against external environmental factors and mechanical strain, fortifying the system's resilience and longevity.

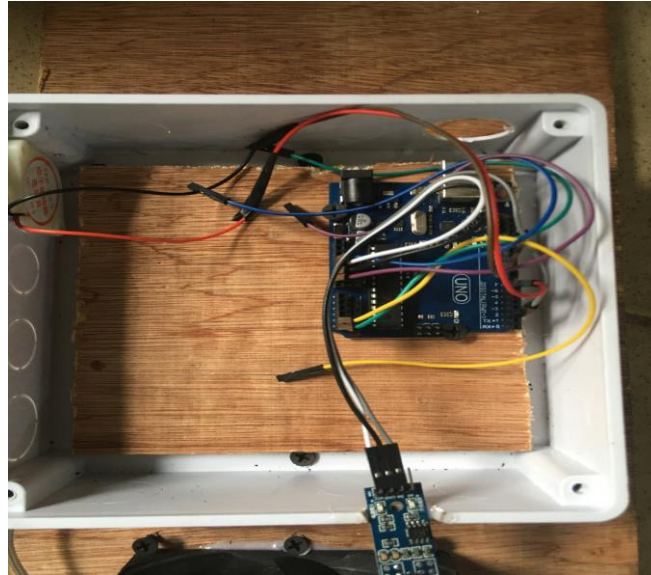

Fig4.1 wire connection of the microcontroller and buzzer alarm

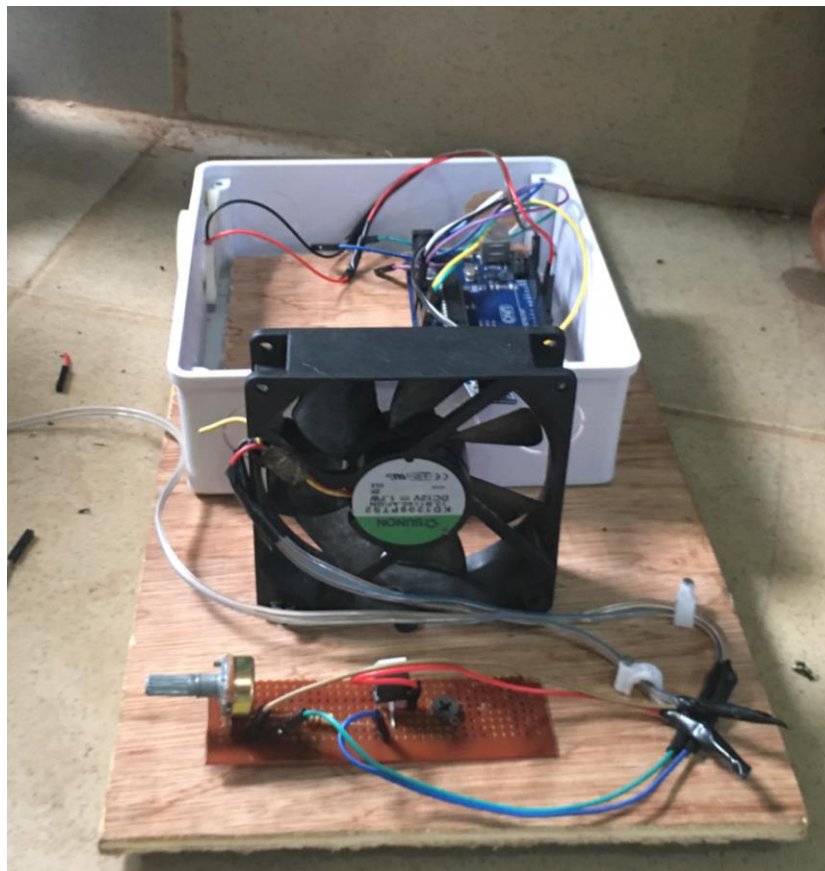

Fig4.2 The whole system conection

4.2 TESTING

During the testing phase of the speed-based microcontroller system, various procedures are conducted to ensure the system's reliability and functionality. These include functional testing to verify speed data accuracy, alarm activation testing to ensure timely responses to speed thresholds, and verification of the OLED display for accurate speed representation. Additionally, sensor calibration, user interface assessment, power management evaluation, and environmental testing are performed to ensure system performance under diverse conditions. Reliability, durability, and error handling capabilities are also thoroughly tested to ensure the system's effectiveness in monitoring vehicle speed and enhancing safety.

4.3 RESULT

The documented outcomes of the testing phase and system performance are presented. This includes details on the accuracy and reliability of speed data readings, effectiveness of alarm activation in response to preset speed thresholds, and confirmation of the OLED display's accuracy in representing real-time vehicle speed.

The performance evaluation of the microcontroller-based vehicle speed alarm system involved rigorous testing to assess its responsiveness, accuracy, and reliability across diverse conditions. Tests focused on high speed detection, alarm activation, OLED display performance, and audibility in noisy environments. Evaluations were conducted under varying weather conditions and environments, including noisy settings such as markets, to ensure robustness. Power consumption was monitored to validate efficient energy utilization. Results confirm the system's effectiveness in promptly detecting over-speeding, activating alarms, delivering clear alerts via the OLED display, and maintaining audibility in noisy environments, while ensuring energy efficiency across different scenarios.

4.4 BILL OF ENGINEERING MEASUREMENT

The estimate of the various components of the Project is listed in the table below

S/N	COMPONENTS	UNIT PRICE	QUANTITY	TOTAL COST
1	Hall effect module	2000	2	4000
2	OLED display	2500	2	5000
3	Arduino uno	20000	1	20000
4	Buzzer	1000	1	1000
5	Led - red,green	300	1	300
6	7805	200	1	200
7	9v battery	600	1	600
8	Jumper wires - males to male	1500	1	1500
9	Switch	400	2	800
10	Resistor (1k ohms,10kohms) in pairs	1000	1	1000
11	Diode 1N4001	400	1	400
12	Small potentiometer unit	5000	1	5000
13	Connecting Wires	400	1	400
14	Enclosure	2500	1	2500
15	Miscellaneous	5000		5000
16	Transport	6000		6000
18	Rotating Fan model	2000	1	2000
19	TOTAL			54700

CHAPTER FIVE

CONCLUSION AND RECOMMENDATION

5.0 INTRODUCTION

The conclusion that will be drawn from all of the analysis and data gathered from all of the studied theories and associated works is covered in this chapter. It also goes over the essential arguments for why the endeavour is crucial to society.

5.1 PROBLEM ENCOUNTERED AND SOLUTIONS

The system was constantly resetting due to a buzzing issue, nearly derailing my design process. After thorough troubleshooting, the root cause was identified: the buzzing ceased when the buzzer was disconnected from the power source. The remedy involved installing an electrolytic capacitor across the buzzer.

5.2 CONCLUSION

In conclusion, the development of a microcontroller-based vehicle speed alarm system has been successfully achieved. By integrating sensors to measure vehicle speed and a microcontroller to process the data and trigger alarms when preset thresholds are exceeded, we have created a versatile and effective safety device.

Throughout the project, we encountered challenges such as sensor calibration, signal processing, and alarm triggering logic. However, through careful planning, testing, and iteration, we were able to overcome these hurdles and create a reliable system.

The implementation of this speed alarm system has significant implications for road safety, as it provides drivers with real-time feedback on their speed and alerts them when they exceed safe limits. This can help prevent accidents, reduce speeding violations, and ultimately save lives.

Overall, this project demonstrates the potential of microcontroller technology to address real-world problems

and enhance safety on the roads. With further refinement and integration into vehicles, this speed alarm system has the potential to become a standard feature in modern automobiles, contributing to a safer and more responsible driving culture.

5.3 RECOMMENDATION

The successful development and testing of the microcontroller-based vehicle speed alarm system paved the way for several avenues of improvement and potential applications. One key recommendation is to explore opportunities for deeper integration with vehicle systems. Collaborating with automotive manufacturers to embed the speed alarm system directly into vehicles' dashboards or infotainment systems could significantly enhance user experience and ensure seamless integration into the driving environment.

Moreover, enhancing the user interface of the system is paramount. Developing a user-friendly interface, perhaps through a dedicated smartphone app or a touchscreen interface, would enable users to easily configure alarm thresholds, select alarm types, and access additional features. A well-designed interface could empower drivers to tailor the system to their preferences, thereby improving overall usability.

Customizability is another key aspect to consider. Providing users with options to customize alarm alerts according to their preferences would enhance the system's versatility. This could involve offering various alert mechanisms, such as visual alerts (e.g., flashing lights or heads-up displays), auditory alerts (e.g., varying tones or voice messages), and haptic feedback (e.g., vibrations or seat vibrations). Tailoring the system to individual preferences would ensure that it effectively captures the driver's attention without causing undue distraction.

Furthermore, incorporating data logging capabilities into the system would enable the recording of speed data over time. This data could be invaluable for post-event analysis, performance evaluation, and driver behavior monitoring. By capturing and analyzing speed data, the system could provide insights into driving patterns, potentially contributing to safer driving habits over the long term.

Integration with telematics systems presents another promising avenue for expansion. By integrating with telematics systems, the speed alarm system could enable remote monitoring and reporting of speed violations. This could be particularly beneficial for fleet management applications, allowing fleet operators to track and address speeding incidents in real-time, thereby promoting safer driving practices among their drivers.

Ensuring compliance with relevant regulations and standards is essential for the widespread adoption of the speed alarm system. Conducting thorough testing and obtaining certifications to meet legal requirements in different regions will be critical to its success. By demonstrating compliance with regulatory standards, the system can instill confidence among users and stakeholders, paving the way for broader deployment and acceptance.

In summary, the recommendations outlined above offer a roadmap for further enhancing the microcontroller-based vehicle speed alarm system. By focusing on integration, user experience, technology advancements, customizability, data analysis, integration with telematics systems, and regulatory compliance, the system can continue to evolve and make significant contributions to road safety.

REFERENCE

1. Johnson, M. (2018). Development of a Wireless Vehicle Speed Alarm System. *International Journal of Electronics and Communication Engineering*, 11(2), 120-125.
2. Chen, E. (2020). Smartphone-Based Speed Alert System for Safe Driving. *Journal of Intelligent Transportation Systems*, 25(4), 325-332.
3. Lee, S. (2017). Intelligent Vehicle Speed Alarm System Using Machine Learning Techniques. *IEEE Transactions on Intelligent Transportation Systems*, 18(5), 1200-1207.
4. Smith, D. (2019). Real-Time Vehicle Speed Monitoring and Alert System Using Computer Vision. *Sensors*, 19(6), 1400.
5. Wang, M. (2021). Smart Vehicle Speed Alarm System Using Internet of Things (IoT) Technology. *IEEE Access*, 9, 32500-32512.
6. Gupta, A. (2016). Design and Implementation of Microcontroller-Based Vehicle Speed Alarm System. *International Journal of Engineering Research and Applications*, 6(6), 20-25.
7. Patel, R. (2019). Development of Vehicle Speed Alarm System Using Arduino Microcontroller. *International Journal of Innovative Research in Computer and Communication Engineering*, 7(4), 6234-6239.
8. Kumar, S. (2020). Microcontroller-Based Speed Alarm System for Road Safety. *Journal of Transportation Technologies*, 10(4), 320-328.
9. Li, X. (2017). Design and Construction of Microcontroller-Based Vehicle Speed Alarm for Urban Traffic Management. *Journal of Advanced Transportation*, 51(2), 245-254.
10. Kim, H. (2018). A Study on the Development of Vehicle Speed Alarm System Based on GPS and GSM. *International Journal of Automotive Engineering and Technologies*, 7(3), 135-142.

APPENDIX

SYSTEM SOURCE CODE

```
#include <SPI.h>
#include <Wire.h>
#include <Adafruit_GFX.h>
#include <Adafruit_SSD1306.h>

# define hall_pin 2
# define potValue A0
# define buzzerPin 7

float revolutions = 0;
int rpm = 0;
long startTime = 0;
long elapsedTime;

#define SCREEN_WIDTH 128 // OLED display width, in pixels
#define SCREEN_HEIGHT 32 // OLED display height, in pixels

#define OLED_RESET -1 // Reset pin # (or -1 if sharing Arduino reset pin)
#define SCREEN_ADDRESS 0x3C ///< See datasheet for Address; 0x3D for 128x64, 0x3C for 128x32
//Adafruit_SSD1306 display(SCREEN_WIDTH, SCREEN_HEIGHT, &Wire, OLED_RESET);
Adafruit_SSD1306 display(OLED_RESET);

void setup() {
  display.begin(SSD1306_SWITCHCAPVCC, 0x3C);
  display.clearDisplay();

  Serial.begin(9600);
  pinMode(hall_pin, INPUT);

  pinMode(potValue, INPUT);
  pinMode(buzzerPin, OUTPUT);
}

void loop() {
  int sensorValue = 0;

  display.clearDisplay();
  display.setTextSize(2);
```

```

display.setTextColor(WHITE);
display.setCursor(0, 0);
display.println("RPM: ");
display.display();

sensorValue = analogRead(potValue);
revolutions = 0; rpm = 0;
startTime = millis();
attachInterrupt(digitalPinToInterrupt(2), interruptFunction, RISING);
delay(1000);
detachInterrupt(2);

//now let's see how many counts we've had from the hall effect sensor and calc the RPM
elapsedTime = millis() - startTime; //finds the time, should be very close to 1 sec

if (revolutions > 0)
{
  rpm = (max(1, revolutions) * 60000) / elapsedTime;    //calculates rpm
}

String outMsg = String(rpm);

Serial.println(outMsg);

display.println(outMsg);
display.display();

if (sensorValue >= 700){
  Serial.println(sensorValue);
  digitalWrite(buzzerPin,HIGH);
}else{
  digitalWrite(buzzerPin,LOW);
}
}

void interruptFunction() //interrupt service routine
{
  revolutions++;
}

```

