

DESIGN AND CONSTRUCTION OF A 5KVA INVERTER

BY

ADEBAYO OSAKPOLOR

PSC1709454

DEPARTMENT OF PHYSICS,

FACULTY OF PHYSICAL SCIENCES

UNIVERSITY OF BENIN

BENIN CITY.

SUPERVISOR: Prof. S.O. AZI

DECEMBER 2022

DESIGN AND CONSTRUCTION OF A 5KVA INVERTER

BY

ADEBAYO OSAKPOLOR

PSC1709454

**A PROJECT SUBMITTED TO THE DEPARTMENT OF PHYSICS,
FACULTY OF PHYSICAL SCIENCES, IN PARTIAL FULFILMENT OF
THE REQUIREMENTS FOR THE AWARD OF THE DEGREE OF
BACHELOR OF SCIENCE (B.Sc.) OF THE UNIVERSITY OF BENIN,
BENIN CITY, EDO STATE, NIGERIA.**

SUPERVISOR: Prof. S.O. AZI

DECEMBER 2022

CERTIFICATION

This is to certify that this project work was carried out by OSAKPOLOR

ADEBAYO in the Department of Physics, University of Benin, Benin City, Edo State Nigeria, under my supervision.

.....

.....

PROF S.O. AZI

DATE

PROJECT SUPERVISOR

.....

.....

PROF. O.D. OSAHON

DATE

HEAD OF DEPARTMENT

.....

.....

.....

EXTERNAL EXAMINER

DATE

DEDICATION

I am dedicating this project to my mum, Mrs. Kate Nosa and also my dad Mr. Nosa Adebayo Thank you so much for all the love and moral support you gave me that brought me to this level. I am grateful.

ACKNOWLEDGEMENTS

I cannot express enough thanks to my project committee and lecturers for their continued support and encouragement: Prof. Azi, my project supervisor and Dr. John. I offer my sincere appreciation for the learning opportunities provided by them.

My completion of this project could not have been possible without the support of my course-mate who are also part of this project, Asher, Emmanuel, Victor, Edwin, Patrick, Ayo, Queensley, and my uncle Mr. Jeffrey. Thank you for the continued support and encouragement. Thanks to my father, Mr. Emmanuel Alekeobor for your prayers and financial support.

ABSTRACT

An inverter is an electronic device use to convert direct current (DC) to an alternating current (AC). The alternating current can be set at a required voltage and frequency, which depends totally on the transformer, control circuit (chipset) and switching use during the time of production. An inverter is essentially a household device that convert power stored in a battery, windmill, solar panel to power every household appliance within it load capacity. That is to say, it supplies AC power from a DC source.

Solid state inverter does not have any moving part like motor and are used in wide range of applications, from small switching power supplies in computers to heavy electric utility high voltage DC applications that transport large amount of power. Also, an inverter performs the opposite function of a rectifier. When designing an inverter, there is one thing you want to be cautious of, which is; what appliances am I using with the inverter.

After Designing, the circuit was divided into four stages which are the; Drivers stage, Buffering stage, Oscillation and the Output stage. All these stages put together make up a whole inverter.

TABLE OF CONTENT

TITLE PAGE	I
TITLE PAGE	II
CERTIFICATION	III
DEDICATION	IV
ACKNOWLEDGEMENT	V
ABSTRACT	VI
TABLE OF CONTENT	VII
CHAPTER 1	1
Introduction	1
Aim and Objectives	3
Scope/ Limit of the Project	4
Organization of the project	5
Summary	7
CHAPTER TWO	8
Literature Review	8

Description of components	11
Transformer	11
Capacitor	13
Resistor	14
Transistor	15
Opto-isolator	16
Summary	17
CHAPTER THREE	18
Methodology	18
Power inverter block diagram	18
Oscillator unit, driver stage and buffer unit	18
Oscillator circuit	19
Buffer stage	21
Buffer circuit	21
Change over stage	23
Feedback	24
Principles of operation	24
The Circuitry Design of the inverter	25

CHAPTER FOUR	28
Results and Discussion	28
Component sourcing	28
Prototype construction	29
Actual constructions	30
Construction testing and result	32
Trouble shooting	32
CHAPTER FIVE	34
Findings	34
Conclusion	35
Suggestion for further research	36
Reference	38

CHAPTER ONE

INTRODUCTION

Today, it is widely known that the electrical power supply isn't reliable. In various countries around the world, the continuous power supply interruption has affected various electrical equipment, causing them to malfunction. This has crippled the operations of various businesses, and this has also affected the economy of Nigeria. Power supply disturbance is regarded as a type of power pollution, and there has been an increase in this phenomenon. The rise of power supply disturbance is regarded as a type of power pollution. It can cause various problems such as high voltage spikes and sudden drops in voltage. These can affect the performance of equipment in a corporate or private organization.

It is certainly a challenging situation in Nigeria, where the supply of electrical power is often unreliable and inconsistent. This can have significant impacts on individuals, businesses, and the overall economy. The issues you mentioned, such as natural disasters, vandalism, lack of investment in the power sector, and inadequate human resources, all contribute to the problem of poor quality power supply. It is clear that addressing this issue will require a comprehensive approach that addresses all of these factors, and more. This may include measures such as upgrading and maintaining infrastructure, improving maintenance and sustainability practices, increasing local content, and investing in human capacity building. Ultimately, it will take a combination of efforts

from government, industry, and other stakeholders to address the challenges and improve the reliability of power supply in Nigeria.

The Institute of Electrical and Electronics Engineers (IEEE) recommends that electrical power supplies should be continuous, uninterrupted, and within the specified voltage and current limits to ensure the proper functioning of modern technological equipment. These recommendations are particularly important given the sensitivity and complexity of many modern devices. Ensuring that electrical power supplies meet these standards is crucial for the proper operation of technology and can help prevent disruptions and damage to equipment.

Over the past several decades, significant progress has been made in developing alternative sources of energy, including independent power systems that can generate electricity using renewable sources such as solar or wind. Many of these systems produce direct current (DC) electricity, which is not always suitable for use in homes and other buildings, where alternating current (AC) is more commonly used. In order to convert DC to AC, a device called an inverter is used. Inverters are designed to transform DC electricity into AC power of a constant frequency, which can then be used to power electrical circuits in homes and industries. Inverters play a critical role in enabling the use of alternative energy sources, and are an important part of many renewable energy systems.

An inverter is an electronic device that converts direct current (DC) electricity into alternating current (AC) electricity. This allows DC power from sources such as solar panels or batteries to be used with AC appliances or integrated into the electrical grid. Inverters can be designed to produce AC power at a variety of voltages and frequencies, using transformer, switching, and control circuits. Inverters are commonly used to provide AC power from DC sources in situations where the AC main power supply is not available. In these cases, the inverter can provide a constant AC supply to connected loads, even when the AC main power is not present. When the AC main power is available, the inverter can detect its presence through an AC main sensor and relay, and pass the AC main power directly to the inverter's output sockets.

The electrical inverter e.g. 5000watts or 5KVA, 220-240v, 50Hz, is high power electronic oscillator. It is also named because early mechanical AC to D.C converters were made to work made to work in reverse and thus were “inverted” to convert D.C to A.C. the inverter performs the opposite function of a rectifier.

If one wants to select an inverter, of 5000watts and the total load to be connected is 5000watts. Then the Power factor of an inverter which generally between 0.6 and 0.8. therefore the recommended Inverter power which is $5000/0.8$ will be 6250 VA So select a 7000VA inverter to run 5000watts loads.

AIM AND OBJECTIVES OF THE PROJECT

Aim of this project is to analyze and build the circuitry for a 5KVA DC-AC inverter.

Objectives are to

- Design the Oscillation circuit.
- Design the Buffering circuit.
- Prototype the circuit on a breadboard.
- Test the inverter circuit.

SCOPE OF THE PROJECT

The scope of this project includes the design and construction of a 5KVA, 220-240volt inverter, which will consist of the following components:

1. Power supply unit
2. Inverting unit
3. Power transformer unit
4. Triggering unit

These components will be integrated to form a functioning inverter that is capable of converting DC power into AC power. The project will involve designing and building each of these units, as well as testing and analyzing the overall performance of the inverter.

The main focus of this project is to demonstrate how low voltage DC power can be used to energize an electrical circuit and how an inverter unit can convert

this power into low voltage AC in the form of a sine wave. The triggering unit is responsible for providing the pulses needed for the MOSFET to operate.

In general, inverter systems have a number of benefits and features, including:

1. Noiseless, fuel-free, and maintenance-free operation
2. High charging current for fast recharging, up to 5 times faster than traditional systems
3. Bypass mode that allows for charge-only operation
4. Compatibility with generators, enabling longer runtime
5. Unlimited battery expansion capability to increase runtime
6. UPS function for automatic changeover to battery power in the event of a power outage
7. Automatic voltage regulation to maintain stable power output
8. Brownout and overvoltage protection to prevent damage to connected devices
9. Compact size and lightweight design
10. Reverse polarity warning to alert users to potential issues with battery connection.

ORGANIZATION OF THE PROJECT

The 5KVA, 220-240v, 50Hz inverter is built using various electronic components, including resistors, capacitors, semiconductor, diodes, transistors (MOSFETs), Integrated circuits (ICs)

Transformer.

The MOSFET is a particularly important component in the inverter, as it plays a key role in the conversion of DC to AC power. MOSFETs are widely used in inverters and other power electronic devices because of their high switching speed, low on resistance, and low voltage drop, which make them well-suited for use in high-power applications.

This 5KVA inverter project report is organized as follows:

Chapter one provides an overview of the project, including its background, objectives, and the importance of inverters in the modern world. It also discusses the different types of inverters and their applications.

Chapter two presents a review of the literature on inverters, drawing on the insights and opinions of experts in the field of electronics.

Chapter three describes the methodology and various components used in the construction of the inverter, including resistors, capacitors, diodes, transistors, integrated circuits, and transformers.

Chapter four outlines the construction process for the inverter, including the steps involved in assembling and testing the different components.

Chapter five discusses the findings and overall conclusion of the project, including any challenges or limitations encountered and potential future improvements.

SUMMARY

In this chapter, an inverter has been described and introduced. The relevance of an inverter system as well as its objectives was also shown in this chapter one.

CHAPTER TWO

LITERATURE REVIEW

According to a book by Owen (1996), inverters have been used to convert DC to AC power since the late 19th century. In the early 20th century, vacuum tubes and gas-filled tubes began to be used as switches in inverter circuits, with the thyatron being the most commonly used type. During this time, rotary inverters or motor-generator sets were also used for DC to AC power conversion.

The origins of electromechanical inverters explain the source of the term inverter. Early A.C to D.C to converters used an induction or synchronous A.C. Motor direct-connected to a generator so that the generator's commutator reverses its connections at exactly the right moments to produce D.C. A later development is the synchronous converter, in which the motor and generator windings are combined into one armature, with slip rings at one end and commutator at the other end and only one field frame.

The result with either A.C. in D.C. out with an M-G set, the D.C. can be considered to be separately generated from the A.C. with a synchronous converter, in a certain sense it can be considered to be "mechanically rectified A.C". Given the right auxiliary and control equipment, an M-G set of rotary converter can be "run backward" converting D.C to A.C. Hence, an inverter is an inverted converted.

It should be noted that since 1954 there have been many high voltage D.C transmission system implemented around the globe with the advent of DC/AC converters; allowing the easy stepping up and down of D.C voltage.

Like D.C power, there exist many devices such as power tools, radio and TVs that run OFF of A.C power. It is therefore crucial that both forms of electricity transmission exist; this world cannot be powered with one simple form. It then becomes a vital matter for there to exist easy ways to transform D.C to A.C power and vice versa in an efficient manner.

According to **Hatziadoni**, (1999), an inverter provides a solution that can that solves the grid interface.

Muhammad, (2010) explained in his book, Power Electronics: Circuits, Devices and Applications. In a basic inverter circuit, the DC input is first filtered to remove any ripple or noise present in the input voltage. The filtered DC voltage is then applied to a switching stage, which consists of power switches (such as transistors or thyristors) that are turned on and off at a high frequency. As the switches are turned on and off, they create a pulse width modulated (PWM) waveform that is used to control the output voltage of the inverter. The PWM waveform is then passed through an output filter, which smooths out the waveform and produces a sine wave or square wave output.

In the same sense, **Bedford**, (1964) in his book “Principles of electronics” shows that this system can also be applied in uninterrupted power supply, induction heating variable – frequency drives, electric drives etc.

Rodriquez, (2002) explained in his book, “multilevel inverters”, how an inverter D.C to A.C. This is more than one technique. The most common is to use an electronic switch to convert the D.C into a square wave. The square wave is filtered to make it a rough sine wave. This can then be passed through a transformer to the desired voltage. The advantage of this system is that it is very efficient. The disadvantage is that the sine wave produced is not all that good a sine wave and some devices (A.C motors) for examples sometimes problems when being powered by inverters.

Mohan, (1995) . wrote on the principles and applications of power electronics. Inverters are a key component of power electronics systems, and they play a crucial role in a variety of applications, including renewable energy systems, electric vehicles, and power electronics. Inverters convert direct current (DC) power into alternating current (AC) power, and they are used to control the magnitude, frequency, and phase of the AC output voltage.

2.1 DESCRIPTION OF COMPONENTS

This chapter of the 5KVA inverter project report discusses the various components used in the construction of the inverter, including resistors, capacitors, bipolar junction transistors (BJTs), unipolar transistors known as MOSFETs, and semiconductor diodes. The chapter begins with a description of transformer principles.

2.2 TRANSFORMER FUNDAMENTALS

A transformer is an electrical device that uses electromagnetic induction to transfer energy between two or more circuits. It consists of two or more circuits, and a change in current in one circuit can induce a voltage in another circuit through the phenomenon of mutual induction.

A transformer circuit consists of a primary and secondary circuit, which are made up of coils, laminations, and a former. The coils are wound around the former to improve the coupling between them and increase their mutual inductance. Power is supplied to one set of coils, known as the primary, from an AC mains supply. The voltage across these coils is either higher (step-up) or lower (step-down) than the supplied voltage. The coils from which power is taken are known as the secondary.

The transformer operates in such a way that when a voltage is applied to the primary windings, an alternating current (ac) is produced in that winding;

this current induces an alternating magnetic flux in the transformer core. Since it works by electromagnetic induction principle, the flux links the whole core and coils.

$$E_1 = \frac{N_1 d\theta_1}{dt}$$

$$E_2 = \frac{N_2 d\theta_2}{dt}$$

E_1 = Primary EMF

N_1 = Primary windings

Nt_1 = Change in flux linkage N_1

E_2 = Secondary EMF

N_2 = Secondary windings

Nt_2 = Change in flux linkage N_2

dt = Change in flux linkage N_2

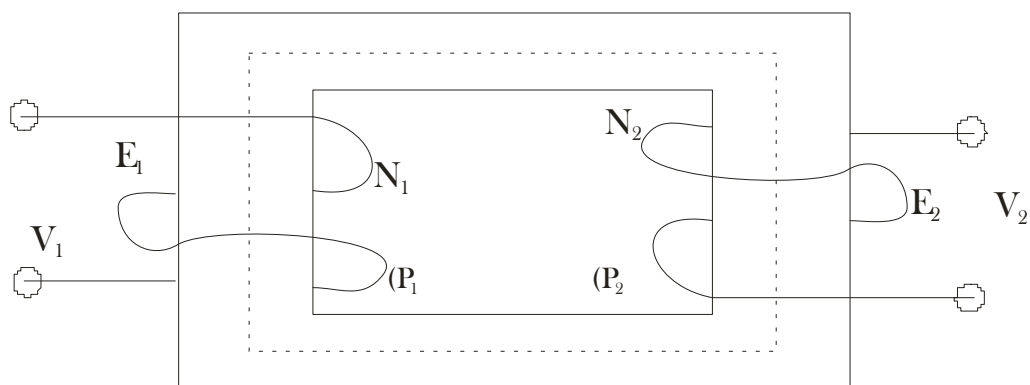

Fig 2.1 Transformer

2.3 Capacitors

A capacitor is an electronic component that consists of two parallel plates separated by a dielectric material. It is used to store electric charges in an electronic circuit and is able to block AC. Capacitors are used for smoothing after rectification, and different types include mica, paper, and ceramic capacitors. In this project, an electrolytic type of capacitor is used.

	Values	Voltage ratings
C_1	$100\mu\text{F}$	25v
C_2	$100\mu\text{F}$	25v
C_3	$200\mu\text{F}$	50v

Table .2.1 various values of capacitors

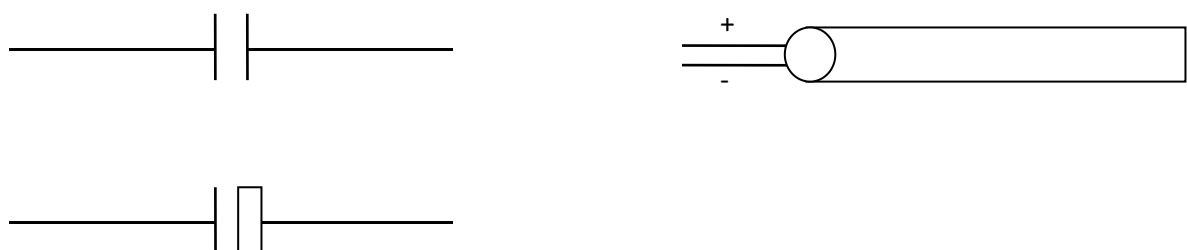

Fig 2.2

Electrical symbols of Capacitors

2.4 Resistors

Resistor is a device that is used to limit the flow of current to different parts of an electronic circuit. Its value determines the amount of current that can flow through it, with higher values resulting in a lower current flow. These resistors are made by pressing and molding a mixture of carbon and clay into rods through heating. They can have values ranging from a few ohms to mega ohms.

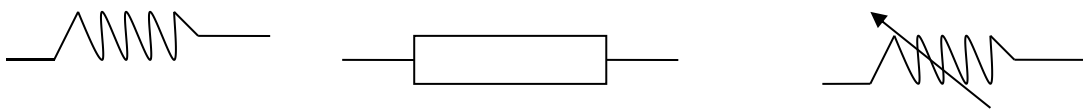

Fig. 2.3 electrical symbols of resistor.

R_1	1k	VR5	100k
-------	----	-----	------

R₂	2.2k	VR5	50k
R₃	100k	VR5	220k
R₄	10k	VR5	1k

Table 2.2 values of resistor.

2.5 TRANSISTORS

A transistor is a type of active electronic device that is commonly used in the design and construction of electronic circuits such as switching and amplifying circuits. It is able to perform these functions, but its effectiveness is largely determined by its connection to other components, such as resistors, capacitors, and inductors.

12Vdc	Transistor output
12Vdc	Pin 1
18Vdc	Pin 4
20Vdc	Pin 6
20Vdc	Pin 8
220Vac	Pin 14
220Vac	Output voltage

Table 2.3 transistor values

TYPES OF TRANSISTOR

Practically there are two types of transistor, these include:

Bipolar Junction Transistor (BJT)

Field Effect Transistor (FET)

OPTOISOLATOR

An opto-isolator, also called an optocoupler or optically coupled isolator, is a component that uses light to transmit signals between two isolated circuits. It consists of an LED on one side and a photodetector on the other side, separated by an insulation layer. The LED is driven by an input signal and emits light, which is received by the photodetector and converted into an output signal.

Opto-isolators are used to electrically isolate two circuits, meaning that they prevent the direct flow of current between the two sides. This can be useful in situations where one circuit is at a different voltage or ground potential than the other, or where there is a risk of electrical interference or noise. Opto-isolators can also provide protection against voltage spikes or surges.

Opto-isolators are commonly used in electronic systems to isolate input and output signals, such as in control systems, data communications, and power supply circuits. They can also be used to isolate sensitive circuits from high voltage or high power circuits, or to isolate a circuit from a noisy environment.

There are several types of opto-isolators, including photocouplers, which use a single LED and photodetector, and transmissive opto-isolators, which use

a pair of LEDs and photodetectors to transmit signals through a barrier. Optoisolators can be used in a variety of applications, including medical equipment, industrial control systems, and automotive systems.

SUMMARY

This chapter has presented a review of the literature, research, and findings of experts in the field of electrical and electronics engineering on the topic of inverters. It has traced the history of inverters, including their composition in the late 19th century and their evolution over time. It has also provided an overview of the circuitry of modern inverters that use MOSFETs.

CHAPTER THREE

METHODOLOGY

3.1 POWER INVERTER BLOCK DIAGRAM

In this chapter, the design and analysis of the inverter system will be presented. The Oscillator, Driver stage and buffer will be presented in details. Each unit of the system will be analyzed, including the parameters that were considered during the design of the 5000 watt, 220-240 volt, 50 Hz inverter system. A block diagram of the inverter system will be provided below.

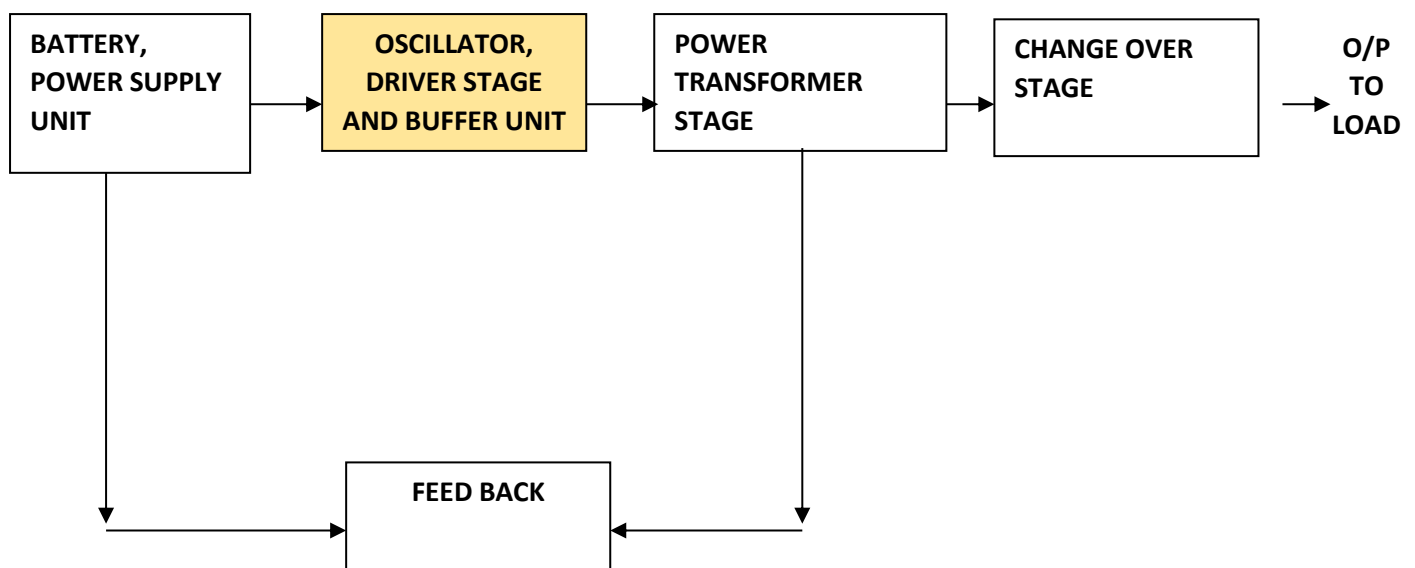

FIG.3.1 BLOCKS DIAGRAM OF 5KVA INVERTER

3.2 OSCILLATOR DRIVER STAGE AND BUFFER UNIT

Oscillators are commonly used in electronic circuits to generate a stable, periodic signal, such as a clock signal or a radio frequency carrier wave. They can be classified based on the type of waveform they produce, such as

Basically Atmega328P-PU IC is a programmable Arduino Chipset. The oscillation frequency is mainly determined by the 16Mhz Crystal.

The oscillator circuit is as shown above. The Atmega328P-PU IC (Integrated circuit) has a lot of internal configurations that helps it to function as an oscillator. It comprises of ICS and filtering components like capacitor and resistor. The oscillator produces a pulsed width output.

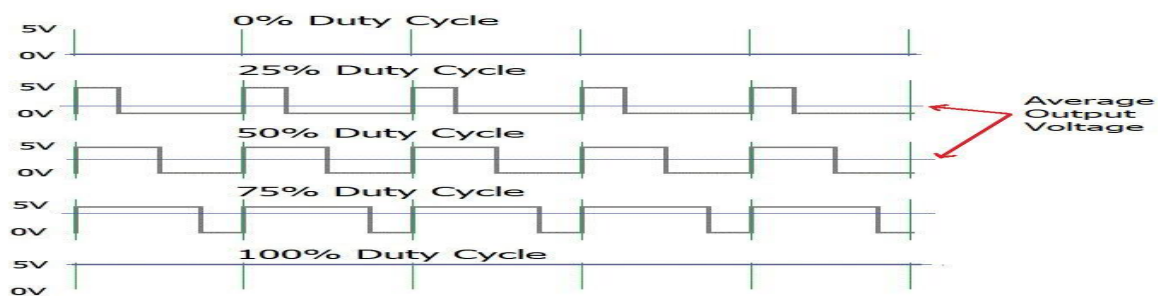

Fig. 3.3 pulse width switching

This particular oscillator has to switch ON/OFF 50 times/sec. Therefore the frequency must be 50HZ. The 10th terminal of the oscillator is known as SHUT-DOWN TERMINAL. The shut-down terminal is used to shut-down the inverter. The shut-down depends on the designer. Whatever he wants to check or control in the inverter can be used as it's shut-down. This particular inverter employs shut-down as automatic changeover, to switch-over to NEPA. The 9th pin is known as the compensation terminal. The compensation acts to

compensate and feedback the error so as to help the inverter to continue supplying its required voltage value regardless of voltage drop because of load.

3.4 BUFFER STAGE

The buffer stage amplifies the output signal produced by the oscillator. It functions like the oscillator, but it is a single amplifier connected in a complementary push-pull configuration. It is a class B amplifier. The buffer stage is made up of transistors, which amplify the output signal from the oscillator.

In this construction work, the buffer stage consists of four N-channels IRF 3205 MOSFET transistor. They are arranged in series, two being connected in series and coupled to one input terminal of the transformer; the other two are also connected in series and coupled to the other input terminal of the transformer.

3.5 BUFFER CIRCUIT

The buffer stage is responsible for amplifying the output signal from the oscillator. The buffer stage is made up of 4 N-channel, IRF 3205 MOSFET TRANSISTOR. Its connection is shown below:

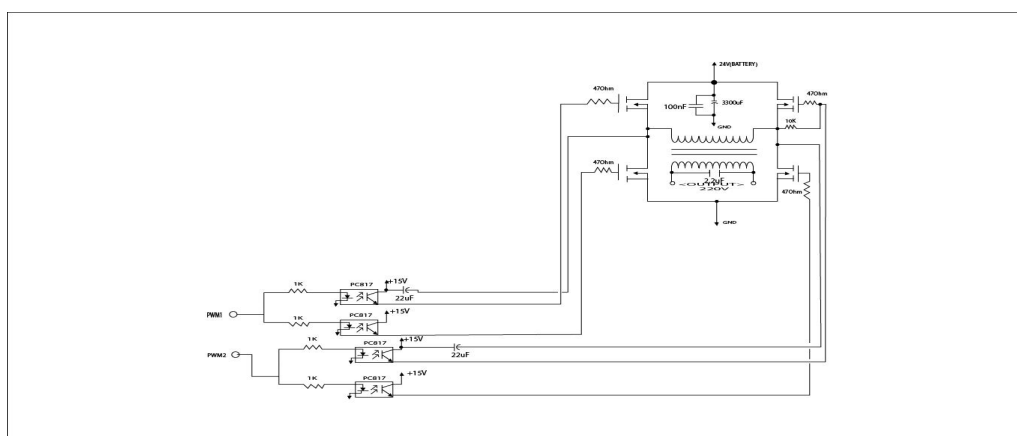

3.6 BUFFER STAGE CIRCUIT

Decision carried out

Maximum current = 200AMP

Load voltage = 24V

Frequency = 50Hz

Shown above is the circuit diagram of a buffer stage. As shown it consists of four IRF 3205 N-channel MOSFET transistor. It has two output which is connected to the input terminal of the transistor.

In this construction of a 5000watts inverter, the MOSFET to use was determined as shown below:

$$P = IV$$

Where $P = 5000\text{watts}$

$$V = 12V$$

$$I = \frac{P}{V} = \frac{5000\text{w}}{24\text{v}}$$

$$= \frac{5000}{24}$$

$$= 208.33\text{A}$$

Therefore, for the inverter to operate properly, the input current rating required by the MOSFET must at least be equal to 200.3A.

3.7 CHANGE OVER STAGE

The purpose of this stage is to automatically switch between the inverter output and the mains supply. When the inverter is producing power, the first relay is activated and the inverter output is supplied to the output socket. When the inverter is not producing power or the mains supply is available, the second relay is activated and the mains supply is supplied to the output socket. This ensures a continuous supply of power to the load, even if the inverter fails or the mains supply is interrupted. The small transformer is used to provide the necessary voltage to activate the relays.

In this inverter system, there are two relays and a small transformer that is used to power the relays. When the mains supply (220-240v) is not available, the inverter system functions normally and the first relay, which is connected to the transformer output terminal, is connected to the socket, allowing the load to be connected. When the mains supply is available, the second relay, which is connected to the mains, is also connected to the transformer output terminal and the socket, allowing the load to be connected. Additionally, the second relay, which is connected to the mains, is used to charge the 12v D.C. battery. The small transformer, which is connected to the mains, energizes the second relay, which makes contact with the mains and transfers the voltage to the transformer

output terminal. The battery begins charging and the voltage is supplied to the socket through the first relay.

When there is no mains supply, the small transformer is energized which de-energize the second relay. The 24v D.C battery will supply voltage which is converted and amplified. Then it is induced in the secondary terminal which supplies voltage of the socket, through the first relay. Note that this happens automatically such that it is not noticed by the human eye.

3.8 FEEDBACK

In summary, the oscillator IC used in this inverter system has a compensation feature that helps to maintain a stable output voltage by feeding back and correcting for any errors, such as voltage drop, that may occur when a load is applied to the system. This ensures that the inverter can continue to supply a consistent voltage despite changes in the load or other external factors.

3.9 PRINCIPLES OF OPERATION

The UPS, or uninterruptible power supply, is a device that provides a steady power source to electronic devices, allowing them to operate for a certain period of time when the main power source is unavailable. The UPS uses a lead acid battery to store energy, which is then used to power the connected electronic devices. It also has the ability to recharge the battery using the ac

power source. In addition, the UPS protects against various power issues that may occur.

3.10 COMPLETE CIRCUIT DIAGRAM OF INVERTER

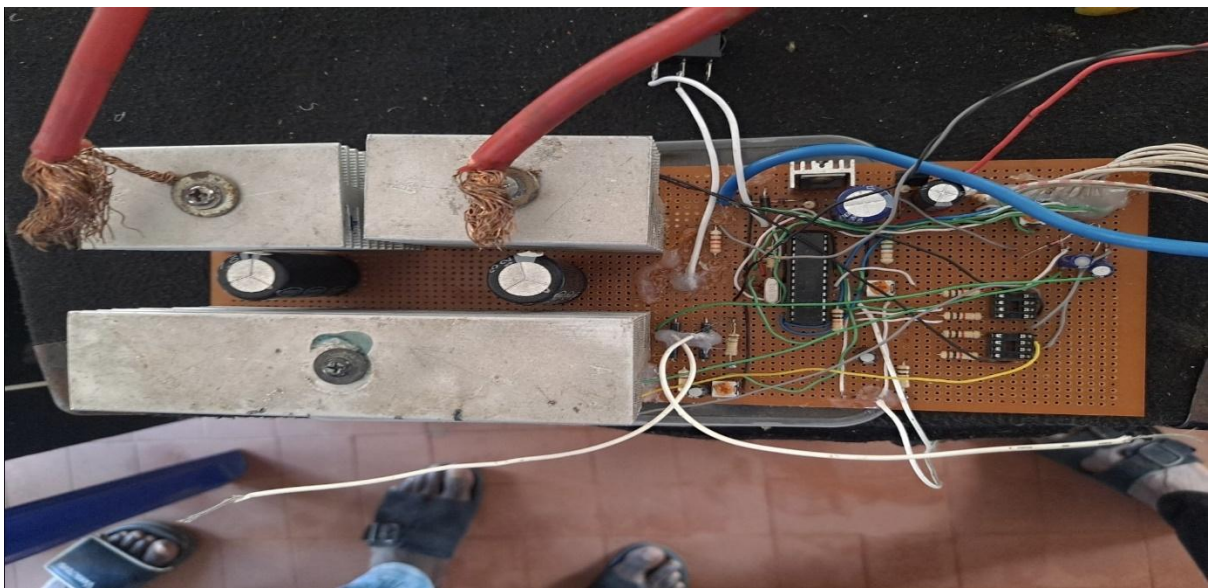

Plate 1 inverter circuit

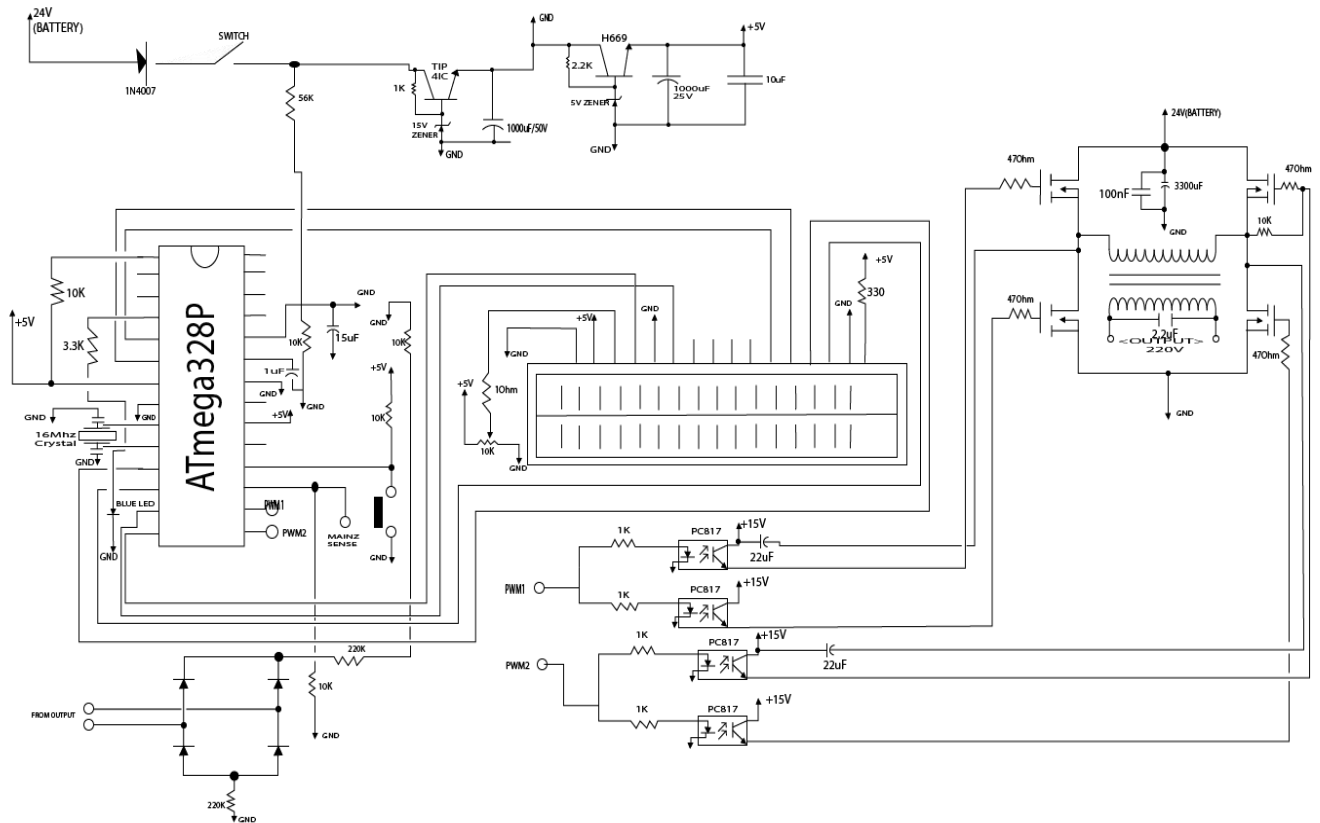

fig 3.5 inverter circuit

In this project, the power supply section accepts the local main supply at 220-240V rms 50Hz and converts it to a form that is suitable for the internal circuit of the system. This means converting the voltage ac mains into a fixed stable dc voltage. The dc voltage output has to remain substantially constant against changes in load current and temperature.

The power supply mains ac (220 - 240v) V_{ac} is converted to about $12V_{ac}$. The center tap transformer connects the $12V_{dc}$ battery to the opto-isolator, which switches on and off automatically. The transistors t1 and t2 serves to receive the voltage from the transformer which is converted to dc voltage. Resistor R1 and R2 absorbs same ac components with the help of C1 and C2

after the transistor t1. They also couple the output of the transistor to the IC ATmega328P. The source of transistor t1 and t2 are grounded.

The variable resistors VR1 and VR2 ensure that the frequency and voltage are varied in accordance with the tune of the output desired. At the inverter, the voltage is converted back to ac with its attendant increase in voltage to 240V ac.

A dc battery (24Vdc) connected at the far end of the center tap transformer ensures constant or uninterrupted power where utility power fails. There is also provision of voltmeter at the output which serves as an indicator to the user to ascertain the quantity of voltage outputted and also an indicator to indicate the charging status.

The dc lead acid battery is continuously recharged as it discharges so that in event of power failure, the reserve energy left the battery can be used to power electronic equipment connected to it for a period up to 20 minutes.

The IC automatically disconnects the mains power and transfers its operation to the dc lead acid battery in event of power failure.

CHAPTER FOUR

4.0 RESULTS AND DISCUSSION

4.1 COMPONENTS SOURCING

In order for a circuit to be successfully constructed, it is important to ensure that all necessary component parts are available and can be sourced easily. A well-designed circuit may not function properly if certain component parts are not readily available. This can be a delicate process, as it is necessary to ensure that the right components are sourced in order to maintain the integrity of the circuit.

It is important to carefully consider the availability and reliability of components when designing an electronic circuit. In some locations, such as Nigeria, it may be necessary to rely on imported components, which can pose challenges in terms of cost and reliability. It is important to be cautious when purchasing components from retailers, as they may try to sell "close substitutes" that may not work as effectively as the original components specified in the design. It is important to carefully research and select components to ensure the success of the electronic circuit.

For the purpose of this project, most of the components used such as IC ATmega328P-PU 2.2 μ f capacitors, and resistors of variable resistances, transformer, transistors and a host of others were sourced in the local market.

4.2 PROTOTYPE CONSTRUCTION

A breadboard is a type of prototyping tool that allows electronics designers to quickly and easily test circuit designs. It consists of a plastic board with holes running both vertically and horizontally, which allows designers to easily connect electronic components together using jumper wires. This allows for the testing of circuits without the need for soldering or permanent connections, making it a convenient tool for prototyping and experimentation.

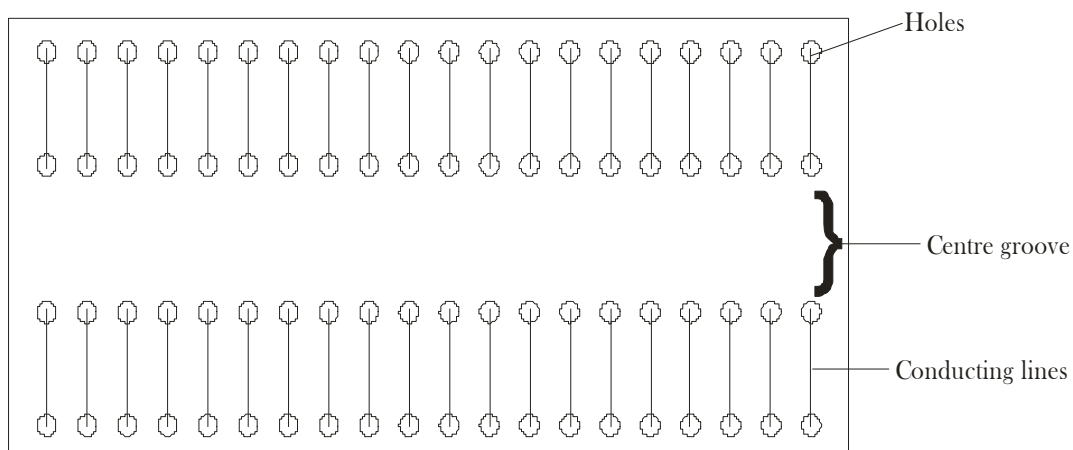

Fig 5.2 Breadboard

Fig 4.1 Breadboard

The breadboard technique is used to test the functionality of a circuit before building it permanently. It consists of a plastic board with holes that contain copper tracks for conducting electricity. Components can be inserted into these holes and connected to each other through the copper tracks. The integrated circuit (IC) and other elements like switches, output sockets, and voltmeters are not inserted into the breadboard, but are connected to it through

jumping wires. This allows for temporary testing and evaluation of the circuit before committing to a permanent build.

The bread board construction is usually essential because modification of the circuit can be easily achieved. The component can be used several times over to make different circuits.

Although it's major limitation is that it may easily develop poor contacts and there is danger of short circuit as base components may touch each other.

4.3 ACTUAL CONSTRUCTIONS

The permanent construction of the inverter system is done on the strip board. The strip board consists of parallel stripes of copper tracks that are fixed on an insulating board. These tracks are of equal width and spaced apart. The components are carefully soldered to the strip board to create permanent joints. This method is used to achieve a permanent fitting of the components and is different from the breadboard construction, which is only a temporary layout used to test the working of the circuit.

The strip board layout involves carefully placing and soldering the components onto the board according to the circuit diagram. The tracks on the board are used to create connections between the various components. It is important to consider the size of the components and the available space on the

board when laying out the circuit. The board can be labeled with letters or numbers to help with organization and to reduce the risk of mistakes during construction. All markings should be made on the non-copper side of the board.

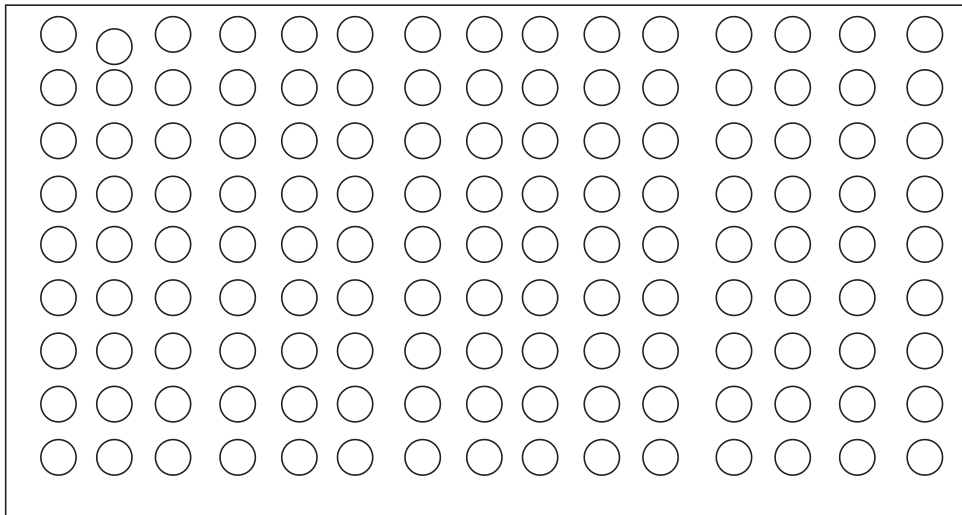

Fig. 4.2 Strip type of Vero board

The soldering process involves the use of a soldering iron to melt a small amount of solder, a type of metal alloy, onto the electrical connections between components on a circuit board. This creates a strong, permanent connection that allows electricity to flow between the components. Proper soldering technique is important to ensure that the connections are secure and reliable, and to minimize the risk of damaging the components or the circuit board itself. This involves heating the components and solder to the correct temperature, using the right amount of solder, and allowing sufficient time for the solder to cool and solidify.

Dry joints are carefully avoided as it may lead to partial contacts or open circuit in the system. However, dry joints have been attributed to so many

failures recorded in a project work. After soldering, the leads are carefully cut with slide cutter to ensure neat work.

Later the strip board is checked of bridged tracks and mistakes from the construction, positive feedback avoided as the output wires made neat contact and are not too close to the input leads.

4.4 TESTING OF THE INVERTER SYSTEM

These tests are important to ensure the proper functioning and safety of the inverter system. The insulation resistance test checks for any potential leaks or issues with the insulation of the system, while the continuity of conductor test verifies the integrity of the conductors. The polarity test ensures that all components are properly connected and that the system is safe to work on and maintain. By performing these tests, any potential issues with the inverter system can be identified and addressed before it is used to power appliances.

4.5 TROUBLE SHOOTING

Trouble shooting involves diagnosis (fault tracing), location and reticulation of faults. Skill in diagnosis allows identification of faults which arises in a system, so that their cause may be found quickly and accurately.

To develop this skill, a logical approach to fault tracing is employed. First there is need to verify the fault by operating the system. After which careful inspection on the system is made, adopting both cold and hot inspection

if cold inspection fails to yield result. Later the system is sectionalized into different stages and then the fault is traced at each stage.

In this project, when the power was first switched on, the indicator failed to light up. This leads into diagnosing the fault and subsequently rectifying it. The fault was traced to open circuit on the indicator lead due to poor soldering. Instruments necessary for trouble shooting includes: oscilloscope, manual and multi meter.

CHAPTER FIVE

5.0 FINDINGS, CONCLUSION AND RECOMMENDATION

5.1 FINDINGS

To design an oscillation circuit for a 5kVA inverter, you will need to consider the following factors:

1. Frequency: The oscillation frequency will determine the switching speed of the inverter and should be chosen based on the load requirements and the switching capabilities of the power transistors.
2. Duty cycle: The duty cycle of the oscillation circuit will determine the average output voltage of the inverter and should be chosen to meet the load requirements.
3. Amplitude: The oscillation amplitude should be chosen to maximize the efficiency of the inverter and minimize the power loss in the transistors.

Designing the buffering circuit for a 5kVA inverter, you will need to consider the following factors:

1. Voltage level: The voltage level of the buffer should be chosen to match the input voltage of the inverter.
2. Current capacity: The current capacity of the buffer should be chosen to meet the load requirements of the inverter.

3. Impedance: The impedance of the buffer should be low enough to minimize the voltage drop across the buffer.

Prototyping the circuit on a breadboard, you will need to layout the circuit components on the breadboard and connect them according to the circuit design.

Testing the inverter circuit, you will need to apply a load to the inverter and measure the output voltage and current. You can also measure the efficiency of the inverter by comparing the input power to the output power.

5.2 CONCLUSIONS

When implementing a design, it is important to have a strong foundation in electronics and physics. This will help the designer to understand what is needed and how to find it in the process of moving from the known to the unknown. It also requires patience and skill to successfully complete a project.

Having the above in mind, this work, power inverter with auto charging panel and changing panel is embarked upon which are now available in most places in Nigeria today.

During the construction process, it is important to pay attention to detail and follow the design specifications carefully to ensure that the final product is functional and meets the desired requirements. It can be challenging to find the necessary materials and components, so it may be necessary to make modifications to the design in order to accommodate for what is available in the

market. It is also important to have a strong understanding of electronics and physics in order to successfully complete a project like this.

It is also necessary to mention that another important constraint to any design is finance, otherwise in this design a more elaborate type having so many specifications could have been undertaken.

5.2 SUGGESTIONS FOR FURTHER RESEARCH

In the text, providing a better understanding of the inner workings of the inverter system. This knowledge can be useful for those interested in making modifications or improvements to the design, as well as for those who need to troubleshoot any issues that may arise during operation. Overall, this work serves as a valuable resource for anyone interested in learning about the construction and operation of power inverters.

This project aims to provide a detailed overview of the design and construction of a power inverter system. It discusses the various components and considerations involved in the design process, as well as the challenges and modifications that may be required during the construction process. The work is intended for researchers, students, and anyone interested in understanding the principles and operation of a power inverter system. It is recommended to consult the references for more in-depth understanding of the topic.

It should be strongly advised that this Power inverter should not be used to substitute the utility power or the generator as it is only designed to complement them.

REFERENCES

Bedford, B.D., Hoft, R.G., ; Principle of inverter circuits pg 13, 1964.

Buckey, P.M, Basic Electronic Circuit, E and FN Spin Ltd, London 1980.

Comer D.J.; Modern Electronic Circuit Design, Wesley A. Publishing Company
1976.

Corner, D.J; Modern Electronic Circuit Design, Wesley A. Publishing Company
1976.

Hatziadoniu. C., Chalkiadakis F.M, IEEE Trans. On Energy conversion, Vol. 14,
No. 4, Dec 1999, pp. 1605-10

Horsely M.P.; Electronic in Practice, Basis Blackwell Ltd, Oxford USA 1986

James E.; Basic Elements of Physical Electronics EL Demark Pub. 2003.

James K.; Light Transistor Etched Project, Howard S. and Co. Inc. Indian Poles
6 India 1963.

James Kylecourpy; Light Transistor Etched Project, Sams H. and Co. Inc.
Indian Poles 6 India 1963.

Loveday G.; Electronics source book for Engineers, Allahabad. All Wheeler
Pub. Co. Ltd. London 1986

Millman J. and Chalkias C.; Integrated Electronics, McGraw-Hill Book
Company-Singapore 1971

Mohan N., Tore M. U and William P. R. Power Electronics: Converters, Applications, and Design, Vol 1, pg 74. 1995.

Muhammad H. Power Electronics: Circuits, Devices and Applications, Edition 3 pg32 , 2010

Okechi G.I.; Design and Construction of an Uninterrupted Power Supply (UPS) PGD Project. Unpublished.

Owen E. L.; Origin of Inverter, IEEE Industrial Application Magazine, Jan/Fed Edition Pg. 64 – 66, 1996.

Rodriguez, J.; et al. Multi-level inverters, A survey of Topologies, control and applications, IEE Transactions on industrial electronics pg. 49, 2002.

Rodriquez J.; et al, Multi-Level Inverters, A Survey Topologies Control and application IEE Transactions on Industrial Electronic pg 49, 2002.

Shrader L.R.; Electronic Communication, New York. Mcgraw-Hill Book Company, USA 3rd Edition, 1975.

Theraja B.L. Electrical Technology, S. Chand and Company Pub. New Delli, 1995.

Therja B.L. and Thereja A.K. (2005); Electrical Technology: pg 4, 116 1116, 2060 and 212.