

DESIGN AND IMPLEMENTATION OF A SOLAR POWER SYSTEM IN
THE FACULTY OF ENGINEERING.



BY:

1	ALETOR GODSPower OSEKHOLENMHEN	ENG2002211
2	AKPETI TRUST EBOSELUMEN	ENG2002210
3	SADOH OMOZUSI OKEOGHENE	ENG2002323
4	AKHARUME FAROUK FRANCIS	ENG2002207
5	AIWEKHoe IYOBOSA EBENEZER	ENG2002202
6	OSEMEN ITUA	ENG2002318
7	DOKPESI EPHRAIM	ENG2002224
8	AIYANYOR VICTOR EFOSA	ENG2002203
9	ODEDEDE EFEGBARE OVIE	ENG2002280
10	IMIANVAN-ANTHONY ONOMEASIKE ANTHONY	ENG2002256
11	EROMOSELE NATHANIEL IBHAKAEHUNUELE	ENG2006257

**THE DEPARTMENT OF ELECTRICAL AND ELECTRONICS ENGINEERING,
FACULTY OF ENGINEERING, UNIVERSITY OF BENIN.**

**IN PARTIAL FULFILLMENT OF THE REQUIREMENTS FOR THE AWARD OF
BACHELOR OF ENGINEERING (B.ENG) IN ELECTRICAL AND ELECTRONIC
ENGINEERING.**

OCTOBER, 2025.

CERTIFICATION

This is to certify that this project was carried out by ALETOR GODSPower OSEKHOLENMHEN (ENG2002211), AKPETI TRUST EBOSELUMEN (ENG2002210), SADOH OMOZUSI OKEOGHENE (ENG2002323), AKHARUME FAROUK FRANCIS (ENG2002207), AIWEKHoe IYOBOSA EBENEZER (ENG2002202), OSEMEN ITUA (ENG2002318), DOKPESI EPHRAIM (ENG2002224), AIYANYOR VICTOR EFOSA (ENG2002203), ODEDEDE EFEGBARE OVIE (ENG2002280), IMIANVAN-ANATHONY ONOMEASIKE ANTHONY (ENG2002256), EROMOSELE IBHAKAEHUNUELE NATHANIEL (ENG2006257), of Electrical and Electronic Engineering Department, Faculty of Engineering, University of Benin, Benin City.

Engr. Prof. Emmanuel A. Ogujor, FNSE,
FNIProd E
Project Supervisor.

Date

Engr. Dr. S. O. Omoroguiwa
Acting Head of Department

Date

DEDICATION

This project is dedicated to Almighty God, whose grace and guidance made this work possible.

We also dedicate this work to our loving families for their constant prayers, support, and encouragement throughout our academic journey.

Lastly, we dedicate this project to every student striving for excellence in the field of engineering. We hope this work serves as a source of inspiration and a contribution to future innovation.

ACKNOWLEDGEMENT

We sincerely appreciate the Almighty God for the strength, wisdom, and guidance throughout this project.

Our deepest gratitude goes to our supervisor, Engr. Prof. Emmanuel A. Ogujor, for his invaluable support, insightful suggestions, and encouragement. We also thank the Head Of

Department, Engr. Dr. S. O. Omoroguiwa, and the entire staff of the Department of Electrical and Electronic Engineering, University of Benin for the knowledge and assistance provided during our academic journey.

We also appreciate all our family and friends for their unwavering support, prayers, and motivation. Your belief in us made this achievement possible.

Finally, we are thankful to one another as team members for the dedication, cooperation, and commitment that each person brought to the success of this project.

ABSTRACT

The project involved detailed load analysis, component selection, and system configuration. The final design ensures a stable power supply with provisions for future scalability. This work demonstrates the practical application of electrical/electronic engineering principles in solving real-world energy challenges and contributes toward the goal of sustainable development.

In this project, the design of a 300kW stand-alone power system for the faculty of Engineering, implementation of a 10kW inverter/battery system for the Dean's office, LT1, LT2, LT3, LT4 and the faculty board room was carried out.

TABLE OF CONTENTS

CHAPTER 11

INTRODUCTION1

- 1.1 BACKGROUND OF STUDY:1
- 1.2 STATEMENT OF PROBLEM:2
- 1.3 AIM AND OBJECTIVES OF THE STUDY:3
- 1.4 SCOPE OF THE WORK:3
- 1.5 LIMITATION OF STUDY:4

CHAPTER 25

LITERATURE REVIEW5

- 2.1 OVERVIEW OF SOLAR ENERGY5
- 2.2 STANDALONE PV SYSTEMS7
- 2.3 PHOTOVOLTAIC PANEL TECHNOLOGIES7
- 2.6 ENERGY STORAGE SYSTEMS12
- 2.9 INVERTER SYSTEMS IN SOLAR INSTALLATIONS20
- 2.11 STAND-ALONE VS GRID-TIED SOLAR SYSTEM25
 - a) Stand-alone solar system25
 - b) Grid-tied solar systems:28
- Table 2.2 Comparative overview of stand-alone and grid-tied systems31
- 2.12 REVIEW OF SIMILAR PROJECTS AND EXISTING INSTALLATIONS31
 - 2.12.1 Project one: design considerations of stand-alone solar photovoltaic systems – W. Ali et al., 201832
 - 2.12.2 Project two: Smart design of stand-alone solar pv system for off grid electrification35

CHAPTER 340

METHODOLOGY40

- 3.1 DESIGN CONSIDERATION AND ANALYSIS40
- 3.2 LOAD ESTIMATION AND ANALYSIS41
- 3.3 INVERTER SIZING43
- 3.4 LOAD SEPARATION43
- 3.5 Battery Sizing52

3.6 PV ARRAY SIZING	56
3.7 CHARGE CONTROLLER SIZING	59
3.8 SYSTEM LAYOUT AND CONFIGURATION	61
3.9 CABLE SIZING	64
3.10 CIRCUIT BREAKER SIZING	71
CHAPTER FOUR	81
RESULT ANALYSIS AND DISCUSSION	81
4.1 COMPONENT SELECTION AND SPECIFICATION	81
4.2 WIRING AND CONNECTION DIAGRAM	84
4.3 INSTALLATION PROCESS	84
4.3.1 Clearing of the installation area	84
4.3.2 Unboxing and inspection of batteries:	85
4.3.3 Unboxing and inspection of inverter:	86
4.3.4 Mounting of change over switch and protective devices	86
4.3.5 Connection and wiring	87
4.4 SAFETY CONSIDERATIONS	89
4.5 Maintenance Considerations	91
4.6 BILL OF ENGINEERING AND MEASUREMENT EVALUATION FOR THE 10KW SYSTEM (DATE: 24 TH OCTOBER, 2025)	92
CHAPTER FIVE	94
CONCLUSION	94
5.1 RECOMMENDATION FOR FUTURE WORK	95
REFERENCES	96

LIST OF FIGURES

Figure 2.1 Block diagram of a standalone PV system

Figure 2.2 A Solar Power System

Figure 3.1 Original DB

Figure 3.2 Original DB (with essential load moved to new DB)

Figure 3.3 New DB (For essential loads powered by inverter)

Figure 3.4 Load Centers and Cable Lengths of the Distribution Network in Engineering

Figure 3.5: MATLAB Simulation of PV Array Capacity

Figure 3.6 System Configuration (Interaction Between The Components)

Figure 3.7 Inverter And Battery

Figure 3.8 Power Distribution Layout for 10kW System

Figure 4.1 Batteries Used

Figure 4.2 Inverter Used

Figure 4.3 Wiring and Connection Diagram

Figure 4.4 Clearing of Installation area

Figure 4.5 Unboxing and Inspection of Batteries

Figure 4.6 Protective devices

Figure 4.7 Inverter and Output Connection

Figure 4.8 Connection of Protective Devices

LIST OF TABLES

- Table 2.1 Comparison of different generations of PV technologies
- Table 2.2 Comparative overview of stand-alone and grid-tied systems
- Table 3.1 Load Estimation Table for The Faculty of Engineering
- Table 3.2: The Load For Each Location In The Faculty
- Table 3.3 The Isolated Load For Each Location In The Faculty
- Table 3.4 The Divided Load For Each Location
- Table 3.5 The Isolated Load For 10kW System
- Table 3.6 System components and their functions in the solar system design
- Table 3.7 Cable Sizing Chart For All Sections in the Faculty of Engineering
- Table 3.8 Cable Sizing Chart For 300kW System Power Distribution
- Table 3.9 Cable Sizing Chart For 10kW System Power Distribution
- Table 3.10 Circuit Breaker Sizing For Mains To Distribution Boards
- Table 3.11 Size Of Circuit Breakers In Step B Distribution Board
- Table 3.12 Size Of Circuit Breakers In Adec Distribution Board
- Table 3.13 Size Of Circuit Breakers In Old 1000LT Distribution Board
- Table 3.14 Size Of Circuit Breakers In Distribution Board 1
- Table 3.15 Size Of Circuit Breakers In Distribution Board 2
- Table 3.16 Size Of Circuit Breakers In Distribution Board 3
- Table 3.17 Size Of Circuit Breakers In Distribution Board 4
- Table 3.18 Size Of Circuit Breakers In Distribution Board F1
- Table 3.19 Size Of Circuit Breakers In Distribution Board F2
- Table 3.20 Size Of Circuit Breakers In Distribution Board F3

Table 3.21 Size Of Circuit Breakers In Distribution Board F4

Table 3.22 Size Of Circuit Breakers In Distribution Board F5

Table 4.1 Specification and Description of Battery Used

Table 4.2 Specification and Description of Inverter Used

Table 4.3 Bill For The 10 kW System

Table 4.4 Bill For 300 kW System

CHAPTER 1

INTRODUCTION

1.1 __BACKGROUND OF STUDY:

The demand for reliable and sustainable energy in Nigerian institutions of higher learning has become increasingly urgent. Within an institution like the University of Benin, where practical experimentation, research, and digital learning heavily depend on stable electricity, it has become crucial to maintain a sustainable energy supply for continuous learning and research activities. However, the limitations of the national grid pose a significant challenge. Frequent power outages disrupt academic activities, reduce productivity, and hinder innovation, especially in laboratories and workshops that require a constant power supply.

Fortunately, Nigeria is endowed with abundant solar energy that can be usefully harnessed with an annual average daily solar radiation of about 5.25 kW h/m²/day. This varies between 3.5 kW h/m²/day at the coastal areas and 7 kW h/m²/day at the northern boundary. The average amount of sunshine hours all over the country is estimated to be about 6.5h (Chineke and Igwiro, 2008). This positions solar power as a practical and renewable energy alternative to fossil-fuel-based energy sources like petrol and diesel generators, especially within institutions, like the University of Benin, that need stable electricity to support teaching, learning, and research.

This project aims to bridge that gap by undertaking the design of a 300kW solar photovoltaic (PV) system specifically for the Faculty of Engineering, University of Benin. It will involve assessing the faculty's energy demand, designing an appropriate solar power solution, selecting suitable components, and implementing a functional system to power key facilities such as lecture theatres, drawing offices, laboratories, workshops, and departmental offices.

In exploring this subject, the individual elements are analyzed thoroughly, and an explanation of how these elements work together to create a cohesive energy system is provided.

Through this project, we will apply core principles of electrical systems design to address this problem, while promoting sustainability, cost-efficiency, and preventing environmental pollution. The outcome will not only enhance power supply within the faculty, but also serve as a practical

demonstration of renewable energy solutions - thereby encouraging wider adoption across the university and beyond.

1.2 __STATEMENT OF PROBLEM:

Supply of sustainable and cost-effective power within the faculty and across the university at large is hampered by several factors, which include;

1. Unreliable power supply: Power supply from Nigeria’s National grid is highly unreliable. In 2024 alone, the grid failed 12 times, plunging large parts of the country into darkness. Despite a recent tariff hike for Band A customers—those meant to enjoy the most stable electricity supply—the power situation continues to deteriorate. (Business day NG, 2024.)

2. Environmental pollution: Fossil fuel power creates pollution in the extraction, transportation, and combustion of its raw materials (Oyedepo, 2012). This carbon emission traps heat in the atmosphere and leads to climate change. The burning of fossil fuels also accounts for a large portion of carbon emissions in the country.

3. Non-renewable energy sources: Most of the power supply alternatives available in the faculty of engineering are non-renewable. This means that their supply is limited and will eventually run out. Therefore, depending on these sources for sufficient power generation in the faculty still does not suffice.

4. Expensive power alternatives: Power supply alternatives available in this region, like running petrol and diesel generators, are quite expensive in terms of maintenance and running costs.

5. Under-utilized solar potential: There is high solar potential available in Nigeria; however, its adoption is limited in public institutions, including universities, due to a lack of awareness, high initial cost, and inadequate technical expertise.

This hampers learning and research activities in the faculty. Hence, there is a pressing need for sustainable and economic power supply to promote a conducive academic environment.

1.3 __AIM AND OBJECTIVES OF THE STUDY:

The aim of this project is to design a 300KW standalone inverter/battery system that can implement solar power supply in the faculty of engineering.

The objectives are as follows;

1. To produce a design and specification for a 300 kW photovoltaic system that can meet the Faculty demand.
2. To carry out detailed load estimation and separation to guide system sizing and Circuit separation.
3. To design and install a 10kW inverter/battery system that is capable of powering the load without solar input, with a suitable battery type and built-in battery management system.
4. To be able to design components, layout, and control schemes that are easy to expand in the future, simple to maintain, affordable to run, with clear ways to fix problems in each building.
5. To provide a platform for final-year engineering students to apply theoretical knowledge in renewable energy systems through hands-on experience in system design, development, and installation.

1.4 SCOPE OF THE WORK:

The scope of this work includes;

1. Performing load analysis, load separation, load estimation and system sizing to determine the total load demand in the faculty.
2. Designing a standalone solar PV system capable of supplying clean energy.
3. Designing and installation of 10kW inverter battery backup system for the main load areas
4. Proposing a layout plan and installation methodology suited for the faculty's infrastructure.

5. Recommending maintenance and operational guidelines to ensure long-term system performance.

1.5 __LIMITATION OF STUDY:

While this project aimed to thoroughly assess, design, and propose the installation of a standalone solar power system for the Faculty of Engineering, some limitations were encountered during the course of the study:

1. Restriction of Access to Key Facilities: Some vital areas within the faculty were difficult to access due to administrative protocols and safety restrictions. This limited our ability to collect real-time data on load distribution.

2. Time Constraints: The time available for data collection and analysis was limited because of the short academic calendar and project deadline. This constraint sometimes affected the depth of technical assessments and the ability to conduct repeated observations or follow-up assessments.

3. Cultural and Institutional Barriers: In a few cases, some staff and custodians of specific facilities were reluctant to grant us access and/or share necessary information, possibly due to internal policies, lack of trust, or cultural perceptions about student-led projects.

This hindered the collection of certain data.

4. Staff Unavailability: Some staff members, including facility managers and technical personnel, were unavailable during crucial periods of data collection. This led to delays and, in some instances, the omission of specific data that would have enhanced the project's accuracy.

Despite these limitations, we made effort to ensure that alternative methods—such as estimations and secondary data sources—were used to fill the gaps and maintain the integrity and feasibility of the project

CHAPTER 2

LITERATURE REVIEW

In this section, our aim is three-fold. We first give an overview of solar energy adoption in the world, and specifically Nigeria. Next, we explore some of the technologies that are involved in designing and building a stand-alone solar power system. Here, we review the design methods used by other authors to size and configure the components appropriately for maximum efficiency. Finally, we review similar projects with the goal of identifying the current approach used in the design of solar systems.

We begin with an overview of the adoption of solar energy systems:

2.1 OVERVIEW OF SOLAR ENERGY

As mentioned in the introduction, Nigeria is plagued with unreliable power supply. This necessitates the development of off-grid renewable energy solutions. Besides the epileptic nature of electricity supply in Nigeria though, the world in general is transitioning towards renewable energy solutions, as the world seeks to be “carbon-free” (Uyigüe and Agbo, 2007).

Solar energy can be harnessed by different means, but this project is focused on the use of PV (photovoltaic) technology, where energy from the sun brings about electron movement — leading to electrical energy. Photovoltaic cells have a long history, starting in 1839 when they were discovered by Edmond Becquerel (Nabi Mughal et al., 2018). Solar energy in recent years has experienced great growth and increased adoption (this increased adoption is visibly obvious here in Nigeria), and this is due to technological improvements resulting in cost reductions (Nabi Mughal et al., 2018).

The measure of solar power that is available on the earth surface is termed solar irradiance (Emmanuel Agbo et al., 2021). The average solar irradiance on the earth is 1000 W per square meter (J. Oji et al., 2012), and this is good power that can be tapped from and utilized well. Emmanuel Agbo in a 2021 article outlined the trend of the world’s installed photovoltaic capacity over the years. He stated that from 1976 to 2000, the capacity jumped

from 0.3 MW to 1500 MW. This capacity further increased to 303,000 MW in 2018. These statistics show that solar energy technology has gotten increased worldwide adoption.

Zoning closer to the African situation though, we see that as at 2018, Africa had only 1.54% of the world's solar energy generation (PV and otherwise). This is poor considering the fact that Africa has high solar irradiance, and Nigeria alone is blessed with 3,000 hours of annual sunshine (Emmanuel Agbo et al., 2021). While it is true that there is an increased adoption of solar systems on a private/individual level in the country, it still has not been implemented into the national grid on a bigger, public scale. It is this fact that necessitates the need and potential for increased adoption of off-grid solutions.

Currently, on a local level, the applications of solar energy technologies include:

- 1) Mobile charger systems: This involves the use of solar power to charge mobile phones, batteries and electronic devices.
- 2) Streetlights: This is an intelligent application of solar power, because it takes advantage of the fact that streetlights are only needed at night, so during the day when they are turned off, they draw power from the sun to charge. This cycle forms a truly renewable process, and these solar powered streetlights are seeing increasing applications. For instance, Vanguard News in January 2025 mentioned that the Lagos State governor approved the procurement and installation of 32,000 solar-powered streetlights.
- 3) Solar-powered off-grid electricity systems for buildings: In 2024 alone, Nigeria added 63.5 MWp (mega-watts peak) of solar capacity (AFSIA, 2025), showing the recent trend of increased solar energy solutions.

Haven had this overview of solar energy systems and their adoption rates, let us delve deeper into the stand-alone solar system and its components.

2.2 STANDALONE PV SYSTEMS

A standalone PV system is one which uses solar energy to produce electricity by means of photovoltaic (PV) technology, and it is independent of the public electricity grid (hence the name ‘standalone’). The block diagram of a standalone PV system is shown below:

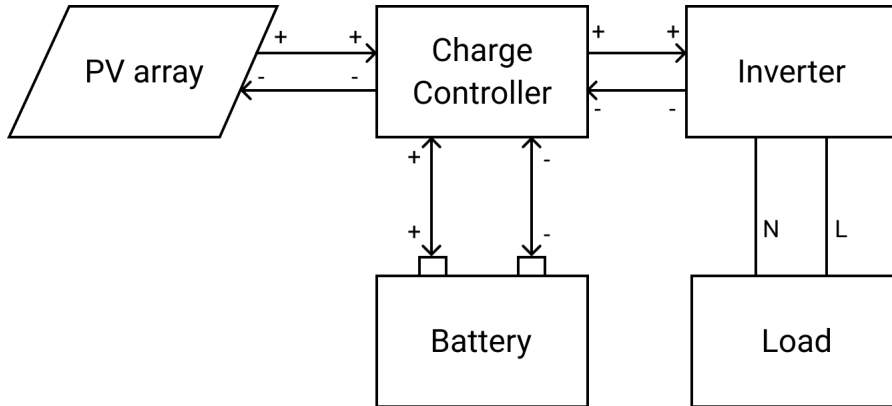

Figure 2.1 Block diagram of a standalone PV system

This leads our discussion to the components that form these block diagram, and the methods used to determine the appropriate capacities and configurations for these components.

2.3 PHOTOVOLTAIC PANEL TECHNOLOGIES

Without a solar panel, there is no solar system. These collect the “life-blood” of the solar system — solar energy. A solar panel consists of units we call solar cells, and solar cell technologies can be broadly split into three generations (Mugdha V Dambhare et al., 2021):

2.3.1 First generation solar cells

These cells are based on crystalline silicon (Si) wafers. They possess the highest commercial efficiency (Gul M. 2016). These crystalline cells could either be single

crystalline (monocrystalline) or polycrystalline. Monocrystalline cells are the most efficient PV technology, with about 15% efficiency (Nabi Mughal et al., 2018). Although according to Zhao et al (1998), polycrystalline solar cells possessing honeycomb like structures have efficiency in the range of 19.8%. Monocrystalline solar cells are slightly more expensive because their manufacturing process is complex. Polycrystalline production is less complex, but the cells produced have lower average efficiencies of 12% (Nabi Mughal et al., 2018).

2.3.2 Second generation solar cells

Because obtaining pure silicon is a very expensive process, the second-generation solar cells resort to using thin films of silicon (1 μm), using a smaller amount of silicon compared to the first generation. Included in this generation is the amorphous silicon PV technology. They are made by depositing silicon in a thin homogeneous layer onto a substrate, instead of using a rigid crystal structure. While it is cheaper, the efficiency is lower — typically at around 6%. The advantages of thin film PV technology are:

- 1) Less material used, hence cheaper cost.
- 2) Low temperature processes.
- 3) Transparent modules can be made.
- 4) Ease of production.
- 5) Third generation solar cells

The third-generation solar cell technology refers to a solar cell which is capable of overcoming the Shockley-Queisser limit of 31-41% efficiency (Mugdha V Dambhare et al., 2021). They represent the frontier of solar technology research and advancement. Many are still in the early stages, undergoing development. Some types of these third generation technology are:

- 1) CZTS solar cells.
- 2) Organic solar cells.
- 3) Dye sensitized solar cells.
- 4) Quantum Dot solar cells.

The different PV technologies can be summarized in the following table:

Table 2.1 Comparison of different generations of PV technologies

	Generation		
	First	Second	Third
Types	Monocrystalline, polycrystalline.	Amorphous solar cell technology.	Organic solar cells, CZTS solar cells.
Efficiency	Highest commercially available — range of 15%	Least efficient — range of 6%	Very high theoretical efficiency — 31-41%
Cost	More expensive because of complexity of manufacturing	Cheaper to produce	Potential for low cost

2.4 EFFICIENCY CONSIDERATIONS

Our aim in designing a solar PV system will be to maximize the amount of renewable energy we can get from the sun and do so with minimum wastage. To do this effectively and get the desired power output, it's essential that we know what factors affect the solar panel output.

Factors affecting solar power output

- 1) **Temperature:** The output of a solar panel is inversely proportional to the ambient temperature (Maryam Rezvani et al., 2022). The higher the temperature of the surroundings, the lower the power gotten from the solar panel. Solar panels are usually rated under a standard temperature of about 25 °C (Nabi Mughal et al., 2018), so once the temperature goes up, the actual power output gotten is less than the rated output. This temperature dependence must be accounted for when designing a solar system to give a certain amount of power.

- 2) **Dust accumulation:** Some studies claim that an increase in dust accumulated on the surface of the panels leads to an increase in the temperature, and hence a decrease in power output (L. Xu et al., 2020). Other studies however claim that dust accumulation leads to a decrease in temperature, but lowers the irradiance and hence the power output. Whatever the case though, what is certain is that an increase in dust levels lowers the efficiency of the solar system.
- 3) **Relative humidity content:** Increasing humidity leads to a decrease in output current, voltage and efficiency of solar panels nearly linearly (V. B. Omubo-Pepple et al., 2009). The effect is worsened considering the fact that relative humidity affects dust accumulation and settling of particles that reduce energy conversion efficiency.
- 4) **Direction:** It is recommended that panels with fixed position should face the south direction for better output throughout the year (Nabi Mughal et al., 2018).
- 5) **Tilt / Angle of inclination:** The tilt of the panel determines how much direct sunlight the panel receives over the course of time, and hence its output. The tilt to use for maximum power output depends on the latitude of the place (Nabi Mughal et al., 2018).

Haven seen the factors that affect the output of the solar panel, let us discuss the design technique for selecting the number of panels to give us a desired power output, taking the essential factors into consideration.

2.5 DESIGN TECHNIQUE FOR SOLAR PANELS

Assuming a system efficiency of 75%, Ariyo et al (2016) gives the total rated power of the panels (rated at Standard Test Conditions) to be:

$$P_{solar} = \frac{E_{req}}{1.25 \times (n \times H_{sun})} \quad (\text{Ariyo et al., 2016}) \quad (2.1)$$

Where,

P_{solar} = total power capacity of panels required (at standard test conditions)

E_{req} = total energy demand in kilowatt-hours (gotten by multiplying the required power by the intended usage duration)

n = factor to account for temperature-dependence of efficiency

H_{sun} = hours of sunlight (obtained from daily solar irradiation). It represents the total time during which the panels receive sunlight with an intensity equal to the standard irradiance level used to rate the panel.

The temperature dependence factor, n , is calculated using this expression:

$$n = 1 - [\gamma_{vmp}(T_{cell} - T_{stc})] \quad (\text{Ariyo et al.2016}) \quad (2.2)$$

Where,

γ_{vmp} = temperature coefficient of solar cells (a typical value for crystalline PV panels is 0.5%)

T_{stc} = cell temperatures at which STC (standard test conditions) ratings are performed. Usually 25 °C

T_{cell} is derived using its own expression

$$T_{cell} = T_{ambient} + G \times \frac{NOCT-20}{0.8} \quad (\text{Ariyo et al., 2016}) \quad (2.3)$$

Where,

$T_{ambient}$ = ambient temperature at place of panel installation

G = the solar irradiance

NOCT = the Nominal Operating Cell Temperature (usually 25 °C)

Haven used all these expressions to get the total panel capacity P_{solar} , finding the number of panels is done by simply dividing P_{solar} by the rating chosen for a single panel. The rating of a single panel is gotten based on a pre-defined list of options available on the market.

In designing a solar power system, the first step is knowing how much power is actually demanded. This is done through a load survey. The total power required for a given type of load (say, lighting loads), is given by the rated power of a single quantity of that load, multiplied by the total number or quantity of the load.

$$Total\ Rated\ Power\ (kW) = Power(kW) \times Quantity \quad (2.4)$$

The daily energy consumption in watt hour / day is given by:

$$Average\ Power = Total\ Rated\ Power \times Load\ Factor \quad (2.5)$$

Using peak sunlight hours, equation 2.1 from Ariyo et al (2016) can be expressed as:

$$Peak\ array\ power\ (kW) = \frac{Daily\ energy\ consumption\ (kWh/day)}{Peak\ sun\ hours\ (h) \times efficiency} \quad (2.6)$$

Part of the configuration of the solar panels also involves determining the output voltage of the array of panels. This output voltage will determine whether the panels will be connected in series or parallel (or both) to achieve the desired output.

2.6 ENERGY STORAGE SYSTEMS

Earlier, we said that solar panels collect the “blood” of the system (solar energy). After converting this solar energy to electrical energy, it has to be stored to be delivered during periods of no or low sunlight. We can therefore compare the energy storage system to the “heart” of our solar system — pumping power through the system.

We will discuss energy storage systems as consisting of both the battery technology, and also the charge controller used to regulate the battery charging and discharging.

2.6.1 Battery Technology

Electrochemical storage systems are what are commonly used to store energy for off-grid solar systems. The following parameters are usually used in discussions concerning battery systems:

- 1) Capacity: Batteries are rated by their voltage output and their capacity in ampere-hours (Ah). This “capacity” represents how much charge the batteries can store and deliver over time.
- 2) Depth of Discharge (DoD): A battery’s depth of discharge is a measure of how much of a battery’s capacity has been discharged compared to its full capacity. Batteries often degrade when they are regularly deeply discharged, and it could cause damage. To prevent such a reduction in lifespan, the DoD shouldn’t be too high. LiFePO₄ batteries can have a DoD of up to 90% though (Eve Energy Co., Ltd., 2019).

There are different battery technologies that are suitable for solar energy applications. We outline some of them along with their use cases.

a) Lead-Acid Battery

Lead acid technologies are the oldest form of battery energy storage and they are a common choice for uninterrupted power supply applications (Chen et al., 2009). They are used in the following applications:

- 1) Backup power supply systems.
- 2) Grid-independent electrical systems.

Lead acid technologies have the following advantages as outlined by Daniel Akinyele et al. (2017)

1. Cheap and readily available.
2. Reliable.
3. Easy to replace.
4. Uninterrupted power supply

Shortcomings of lead-acid technology

In a review of battery storage technologies and their impact in stand-alone PV systems, Daniel Akinyele et al (2017) outlined these shortcomings of lead-acid batteries:

1. Slow charge.
2. Environmental hazard due to a toxic component.
3. Low power density.
4. High maintenance requirement.

b) Sodium-Sulphur Technologies

These technologies were developed by NGK Insulators and Tokyo Electric Power in the year 1987. NaS (Sodium-Sulphur) are one of the most proven systems for mega-watt scale applications (Rastler D.M., 2010). By virtue of their higher round-trip efficiency (ratio of energy output to energy input during a full charge-discharge cycle), they are used for power quality and power time shift purposes. Specific applications include:

- 1) High-Power Energy Management.

Its advantages are:

- i. Relatively high power and energy density.
- ii. They are efficient.
- iii. Economical for power quality and peak shaving purposes.
- iv. The shortcomings to this technology though are:
 - v. Heat source requirement.
 - vi. High cost.
 - vii. Significant self-discharge.

c) Nickel-Cadmium Batteries

Like the lead-acid technologies, they are among the oldest battery technologies. The applications for this type of battery include:

- i. Emergency reserve for communication services.

- ii. Power tools.
- iii. UPS (Uninterrupted power supply).

The advantages of using this form of batteries are:

- i. High mechanical resistance.
- ii. Suitable for telecommunication devices.
- iii. Low maintenance requirement.
- iv. Relatively high energy density

Shortcomings:

- i. High cost.
- ii. Like the lead-acid battery, there is an environmental hazard due to the toxic heavy metal cadmium.
- iii. Memory effect which reduces the capacity.

d) Lithium-ion batteries

These batteries are traditionally used in smaller appliances like mobile phones and laptops. It's round-trip efficiency (RTE) is about 100%, distinguishing it from other battery technologies. The applications of lithium-ion batteries include:

- 1) Electric vehicles.
- 2) Plug-in hybrid electric vehicles.

Advantages:

- 1) Almost 100% efficient.
- 2) Fast response to charge and discharge operations.
- 3) Relatively high power and energy density.

Shortcomings of the lithium-ion batteries:

- 1) High cost compared to other battery technologies.

2) Degradation at high temperatures.

e) Flow batteries

This battery technology is designed to store its energy in its electrolyte solution, which is opposite of other conventional batteries which store energy in the electrodes. They are categorized into two — redox flow batteries and hybrid flow batteries. Daniel Akinyele et al (2017) gives a summary that outlines the advantages and shortcomings of the redox type flow batteries.

Advantages of redox flow batteries:

1) Useful for large-scale applications.

Shortcomings:

1) High cost.

2) Complex standardization.

Of all these technologies, it is worthy of note that the lead-acid battery is a mature technology, and it presents a cheap energy storage option (although it has an environmental hazard as mentioned before).

Now that we have reviewed some of the battery technologies, let us discuss the method used to size the batteries for a stand-alone solar system.

2.7 BATTERY SIZING

From basic physics, the charge capacity of a battery is given from the equation:

$$Energy = Q \times V \tag{2.7}$$

This becomes:

$$Q = \frac{Energy}{V} \tag{2.8}$$

Where,

Q = Charge capacity of battery in ampere-hour (Ah)

Energy = Energy supply required by the solar system in watt-hour (Wh)

V = Voltage of battery array in volts (V)

With a depth of discharge (DoD) of 80-90% though, our battery capacity must be approximately 1.11 to 1.25 times the maximum discharge value. We further multiply this capacity by what (Ariyo et al., 2016) terms autonomy factor, to account for days without any charging.

This can be expressed by the equation:

$$\text{Required Battery Capacity (Wh)} = \frac{\text{Average Load} \times \text{Autonomy}}{\text{DoD} \times \text{Efficiency}} \quad (2.9)$$

Where,

$$\text{Average Load} = \text{Peak Load} \times \text{Load Factor} \quad (2.10)$$

Finally, the number of batteries needed in the array is gotten by dividing this total battery capacity by the individual battery capacity.

The number of parallel paths is determined by the Ah capacity:

$$\text{No. of Parallel Paths} = \text{Total Ah capacity} / \text{Ah capacity of one unit} \quad (2.11)$$

2.8 CHARGE CONTROLLERS

As part of our discussion on energy storage systems, we now want to go on to talk about the charge controllers used in regulating the charge and discharge of these battery systems. First, let us outline why charge controllers are needed in the design of solar power systems in the first place.

2.8.1 Purpose of charge controllers

- 1) Overcharge protection: As implied in their name, charge controllers “control” the charging of a battery, stopping its charging when it reaches its peak capacity. This is essential because it prevents overvoltage which can reduce the battery (and hence the system) lifespan, even causing safety risks.
- 2) Prevention of over-discharge: Some charge controllers perform a load disconnection to prevent the batteries from discharging more than the depth of discharge (DoD). As mentioned earlier, this is vital to maintain the lifespan of the battery – that is the very purpose of having a maximum depth of discharge.
- 3) Voltage and current regulation: Charge controllers perform the function of making sure the voltage and current delivered to the battery are within the safe limits that the battery can accommodate. This is essential for protection in the event of surges and spikes in voltage levels.
- 4) Improving charging efficiency: MPPT (Maximum Power Point Tracking) charge controllers improve charging efficiency by adjusting the solar panel’s operating voltage to make sure that the battery gets the maximum available power from the solar panel.

2.8.2 Charge controller technologies

Nowadays, two charge controller types mostly used are the pulse width modulation (PWM) and the maximum power point tracking (MPPT) controllers (Tulika Majaw et al., 2018). They are both great options to use in the design of solar power systems.

a) Pulse width modulation (PWM) charge controllers

A PWM charge controller controls the average current flowing into the battery by using pulses. When the battery level is low, the pulse is turned on for a higher percentage of the time than it is off (high duty cycle). When the battery approaches full voltage however, the average current is reduced. The purpose of this is to allow the battery to be fully charged with less stress applied to it.

Tulika Majaw et al (2018) gives these benefits for the PWM charge controller.

- 1) Reduces battery heating and gassing.
- 2) Maximum high average battery capacities.
- 3) Equalization of battery cells.
- 4) Automatic adjustment for battery aging.

Its disadvantages though are:

- 1) PWM controllers possess limited capacity for system growth.
- 2) They cannot be used effectively with 60A panels.

b) Maximum power point tracking (MPPT) charge controllers

The MPPT is a power electronic device used to improve the efficiency of the solar panel. They are capable of extracting a much higher percentage of the available power from the solar panel, compared to PWM controllers. The advantages of the MPPT charge controller are outlined below:

- 1) They offer an increase in efficiency of up to 30% (Tulika Majaw et al., 2018).
- 2) MPPT charge controllers are used to correct the variations in the I-V characteristics of the PV cell.

It has these shortcomings though:

- 1) MPPT charge controllers are more expensive.
- 2) Generally, they are larger in size.

2.8.3 Factors Affecting Choice of Charge Controller in Stand-Alone Solar System Design

Based on the previous review, the following factors would affect what charge controller should be used in a solar power system.

- 1) **Cost:** The MPPT charge controllers, despite having higher efficiency, are more expensive. Therefore, the cost of having less efficiency from using a PWM charge

controller has to be weighed against the cost of spending more for an MPPT charge controller.

- 2) **Lifespan:** PWM charge controllers have longer expected lifespan (B. Swarnakar and A. Datta, 2016), and so we must consider the cost of having to change an MPPT charge controller in a shorter duration of time than a PWM charge controller.
- 3) **Provision for future expansion:** An MPPT charge controller will allow for increase in number of solar panels (hence panel voltage output), without as much loss in efficiency.

This factor must be considered if the possibility exists of future expansion of the system. But in the case of this project , the charge controller is integrated into the inverter that will be used

2.9 INVERTER SYSTEMS IN SOLAR INSTALLATIONS

Solar inverters are the driving force behind solar energy systems. From small systems like household appliances to large-scale applications like farmlands and manufacturing industries, every photovoltaic system requires a way to convert direct current (DC) power created by solar panels to alternating current (AC) power. This is the main function of inverters - to convert direct current (DC) generated by solar panels into alternating current (AC) required for the operation of electrical appliances. Inverter systems act as the bridge between the PV array and the load or utility grid, ensuring stable and efficient operation of the solar power system.

2.9.1 What is a solar inverter?

An inverter is a device that transforms direct current (DC) into alternating current (AC) required for most electrical applications. Whether converting the DC energy stored in the battery to AC or converting the DC power generated from the solar panels into AC for direct supply, the solar inverter finds relevance in both applications. They serve as a vital link connecting the PV setup to the electrical distribution panel.

2.9.2 Classifications of Solar Inverters

a) Based on System Functionality

1. Off-Grid Inverters:

They are used in standalone solar systems that are not connected to the utility grid. They derive their power from solar panels and battery storage.

Key Features:

- i. Requires a battery bank
- ii. Supplies AC power to loads directly from stored solar energy
- iii. Often includes built-in solar charge controllers
- iv. Applications: Rural areas, remote communities, backup systems

2. Grid-Tied (On-Grid) Inverters:

They operate in coordination with the utility grid, convert DC power to AC and synchronize it with the grid. They find application in homes, offices, and universities connected to the grid.

Key Features:

- i. No batteries required
- ii. Includes anti-islanding protection (shuts off during grid outage)
- iii. High efficiency and cost-effective for net metering

3. Hybrid Inverters

They combine the features of off-grid and grid-tied inverters.

Key Features:

- i. Can work with solar panels, batteries, and the grid simultaneously

- ii. Prioritizes solar, then battery, then grid as backup
- iii. Advanced energy management and load shifting
- iv. Applications: Smart homes, institutions, energy-resilient installations

b) Based on Installation Architecture

1. Central Inverters:

They are large, powerful inverters that handle the output of many solar panel strings. They are mostly employed in industrial or utility-scale solar projects.

Key Features:

Installed in large utility-scale solar farms

Economical for high-capacity systems (>100kW)

Simple design, but single point of failure

2. String Inverters:

Each “string” (series) of solar panels is connected to one inverter.

Key Features:

- i. Widely used in residential and commercial installations
- ii. Easier to install and maintain
- iii. Lower cost per watt compared to micro-inverters
- iv. Limitation: Affects performance when one panel in the string is shaded

3. Micro-inverters:

They are small inverters attached to individual solar panels. They find application in residential, irregular roofs, shade-prone locations.

Key Features:

- i. Performs MPPT for each panel independently
- ii. Maximizes energy production in shaded or complex roof layouts
- iii. High upfront cost, but scalable and efficient

4. Power Optimizers (with String Inverters):

They are module-level DC-to-DC converters used with a central string inverter.

Key Features:

- i. Panel-level MPPT like micro-inverters
- ii. Lower cost than full micro-inverter setups
- iii. Increases efficiency under shading

c) Based on the output waveform

- A. Square wave inverters: They are inverters that give a square AC waveform as output. They are quite old, outdated, and only suitable for resistive loads.
- B. Modified sine wave inverters: They are inverters that output an approximate sine wave. They are inexpensive, often used in small backup systems.
- C. Pure sine wave inverters: They are inverters that output a smooth sine wave. They are standard in all modern PV systems, and safe for all.

2.10 EVOLUTION OF INVERTERS

a) Transformer-less Inverters Topologies

Transformer-less inverters are solar inverters designed without an internal galvanic isolation transformer between the DC input (from PV panels) and the AC output (to the grid). They use high-frequency switching and advanced circuit topologies (e.g, H5, H6, or Neutral Point Clamped (NPC)) to convert DC to AC directly without magnetic isolation. Their topologies have become increasingly popular in PV systems due to the benefits of higher efficiency, light weight, and reduced cost and size.

Conventional inverters use transformers to achieve galvanic isolation between the DC (direct current) side of the PV array and the AC (alternating current) output. However, they are more bulky, more costly, and experience greater energy losses due to inherent resistance and magnetic hysteresis. Eliminating the transformer enables the transformer-less inverters to achieve higher efficiency, a smaller physical footprint, and reduced material costs. This makes them an attractive option, especially for grid-connected systems where isolation is not mandatory.

Despite these advantages, the absence of a transformer presents specific challenges, particularly in terms of safety and reliability. Leakage currents and ground fault currents become prominent issues because, without a transformer, there is no inherent isolation between the PV system's DC side and the grid-connected AC side.

b) Multilevel Inverters

Multilevel inverters are widely used in applications requiring high power levels, high voltage, and superior output quality, making them ideal for PV systems, especially in stand-alone setups and large-scale installations. Multilevel inverters are advanced inverter topologies that produce AC voltage in multiple steps (levels), closely approximating a sine wave, using multiple DC voltage sources or capacitors. The primary goal of multilevel inverters is to produce a sinusoidal-like AC waveform with minimal distortion by combining multiple DC voltage levels. By increasing the number of voltage levels, multilevel inverters can generate smoother output waveforms, reducing harmonic distortion and filtering requirements. This enhances efficiency and power quality, which are crucial in high-power PV systems to meet the standards of grid-tied systems and ensure reliable operation in stand-alone applications. In PV systems, multilevel inverters offer benefits such as high efficiency, lower electromagnetic interference (EMI), and improved power quality, which are essential for applications ranging from residential solar installations to large/industrial solar applications. They are also scalable and modular, making it easier to design systems that meet specific power and quality requirements by increasing the number of levels or modules.

2.11 STAND-ALONE VS GRID-TIED SOLAR SYSTEM

Solar photovoltaic (PV) systems are typically configured as either stand-alone (off-grid) or grid-tied (on-grid) systems. The choice between these two depends on factors such as energy demand, grid reliability, cost, and application. For the 300 kW solar project for the Faculty of Engineering, a stand-alone configuration is proposed to ensure reliable and uninterrupted power supply despite unstable grid conditions.

Solar photovoltaic (PV) systems are commonly designed as either stand-alone (off-grid) or grid-tied (on-grid) systems. A grid-tied system connects directly to the utility grid and supplies power to both the building and the grid. While it can reduce electricity bills and support net metering, it depends heavily on grid stability. If the grid fails, the system typically shuts down for safety reasons, resulting in power loss.

A stand-alone system, on the other hand, operates independently from the grid. It generates electricity from solar panels and stores excess energy in batteries for later use. This setup is especially useful in areas with unreliable or no grid access, as it guarantees a continuous supply of power even during outages.

For the 300 kW solar PV project planned for the Faculty of Engineering, a stand-alone configuration has been selected. This choice is based on the frequent grid failures experienced on campus and the critical need for constant power supply in laboratories, classrooms, and administrative offices. The system will consist of solar panels, battery storage, charge controllers, and inverters to ensure stable and uninterrupted electricity. It will be designed to meet the faculty's peak power demand while providing backup energy during low-sunlight hours.

a) Stand-alone solar system

Stand-alone systems operate independently of the public grid and consist of solar panels, charge controllers, inverters, and batteries for energy storage. They are ideal for areas with poor or unreliable grid connections. A stand-alone solar system, also known as an off-grid system, is designed to function independently of the national or public electricity grid. It generates electricity using solar photovoltaic panels and stores the energy in batteries for use

during periods when solar generation is low, such as at night or during cloudy weather. The system typically includes key components such as solar panels, charge controllers, inverters, and deep-cycle batteries for energy storage.

This type of system is ideal for remote areas, rural communities, or institutions that experience frequent grid failures. It provides complete energy autonomy and is often used for powering schools, health clinics, farms, security systems, and homes that are far from existing power infrastructure.

Advantages Of Stand-Alone Solar Systems

1) Continuous and Reliable Power Supply:

One of the biggest benefits of a stand-alone system is that it ensures an uninterrupted power supply. Since the system is independent of the public grid, it is not affected by grid outages or fluctuations. For example, in regions where the grid goes off multiple times a day, a well-designed off-grid solar system can still keep essential equipment running such as laboratory computers in a university, or lighting and refrigeration in a rural health clinic. This is especially important for critical operations that cannot afford downtimes.

2) Independence from External Energy Providers:

With a stand-alone system, users are no longer dependent on electricity companies or fuel suppliers. This reduces the risk of unexpected tariff increases or fuel shortages. For example, a small-scale farmer using solar to run irrigation pumps and charge battery-powered equipment doesn't need to worry about the price of diesel or unreliable utility services. Over time, this energy independence can lead to significant cost savings and better control over energy usage.

3) Supports Critical Operations During Outages:

In environments where consistent power is crucial such as university laboratories, telecom towers, or hospitals, stand-alone systems can keep essential systems running even when the grid is completely down. For instance, a faculty research lab running

long-duration experiments can rely on solar power without worrying about interruptions from power failures.

Disadvantages Of Stand-Alone Solar Systems

1) High Initial Cost Due to Large Battery Storage

One of the major drawbacks of stand-alone systems is the upfront cost, especially due to the need for high-capacity battery storage. Batteries are necessary to store excess energy generated during the day for use at night or during cloudy days. For example, a 300 kW solar system for a faculty building may require hundreds of kilowatt-hours of battery storage, which can be expensive. Although the investment pays off in the long run, the starting capital can be a barrier for some institutions or households.

2) Requires Regular Maintenance of Batteries and Charge Controllers

Unlike grid-tied systems that have fewer components, stand-alone systems require regular monitoring and maintenance. Batteries degrade over time and need to be checked for proper charging and discharging cycles. Charge controllers, which manage the power flow from panels to batteries, also need periodic inspection. For example, in a remote health center using an off-grid system, improper battery maintenance could lead to power loss during the night, compromising essential services like vaccine refrigeration.

3) Needs Careful Load and Capacity Planning

Off-grid systems must be carefully sized to meet the energy demands of the user. If the system is under-sized, it may not meet the required load during cloudy days or high-usage periods, leading to power shortages. If it's over-sized, it leads to unnecessary expense. Accurate calculation of daily load consumption, peak demand, and battery autonomy is essential. For instance, a faculty building running equipment like projectors, computers, lighting, and fans must be assessed to ensure the system can handle maximum load without running out of stored energy.

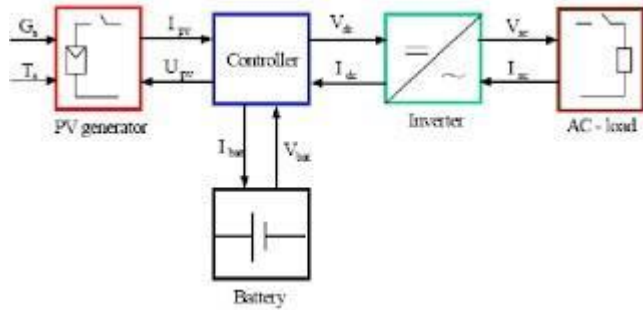

b) Grid-tied solar systems:

Grid-tied systems are connected directly to the utility grid. Generated energy is first used to supply the local load, while excess power can be exported to the grid. These systems typically do not require batteries, making them more cost-effective for grid-connected areas. Grid-tied solar system, also known as an on-grid system, is connected directly to the public electricity grid. It is designed to supply power to local electrical loads (such as lights, appliances, and equipment) while any excess energy generated by the solar panels can be exported back into the grid. These systems typically operate without battery storage, relying instead on the grid to balance energy supply and demand.

When the solar panels produce more electricity than is needed at that moment, the extra energy flows into the grid. Conversely, if the solar output is not enough to meet the demand, electricity is automatically drawn from the grid. This setup makes grid-tied systems ideal for homes, schools, and businesses located in areas where the grid is stable and electricity is available most of the time.

Advantages Of Grid-Tied Solar Systems

1) Lower Installation Cost:

Grid-tied systems are generally more affordable to install than stand-alone systems because they do not require large battery banks for energy storage. Batteries are often the most expensive component of a solar system. By eliminating them, the overall cost is reduced. For instance, a 100 kW grid-tied solar installation for a university lecture building would cost significantly less than a similar off-grid system, making it easier to implement in budget-sensitive projects.

2) Possible Revenue from Net Metering (Where Applicable)

In some regions or countries, grid-tied solar users can benefit from a policy called net metering. This allows them to receive credit or payment for any surplus electricity they export to the grid. For example, during weekends or holidays when power usage is low, a school's solar system may feed extra electricity into the grid and earn energy credits that reduce future bills. However, the availability of net metering depends on local energy regulations and utility companies.

3) Minimal Maintenance:

Because grid-tied systems have fewer components mainly solar panels and inverters, they require less maintenance than off-grid systems. There are no batteries to monitor or replace, and inverters typically have long lifespans. This makes them easier to manage over time, especially in urban or semi-urban settings where professional servicing is accessible.

Disadvantages Of Grid-Tied Solar Systems

1) Power Loss During Grid Outages Unless Paired with Batteries:

One major downside of a grid-tied system is that it does not function during a power outage unless it includes a backup battery system or hybrid inverter. This is a built-in safety feature to prevent solar electricity from back feeding into the grid and endangering utility workers. For example, if there is a blackout during the day, a grid-tied solar system will shut down even if the sun is shining and panels are generating power, leaving the building without electricity.

2) Dependent on Grid Stability:

The efficiency and reliability of a grid-tied system are closely tied to the stability of the local electricity grid. In areas with frequent grid disturbances such as voltage fluctuations or complete outages the system may experience interruptions or even fail to perform efficiently. For example, if a technical fault in the grid causes a sudden voltage dip, the inverter might disconnect temporarily, leading to a momentary loss of power in connected devices.

3) Less Practical in Areas with Frequent Power Failures:

In locations where power outages are frequent or prolonged, a grid-tied system offers limited benefit. Since it cannot operate without the grid, such a system would be unreliable during emergencies or peak usage times. For instance, in a town where electricity may be off for several hours each day, a grid-tied system would be less effective than a stand-alone or hybrid solution that can provide consistent backup.

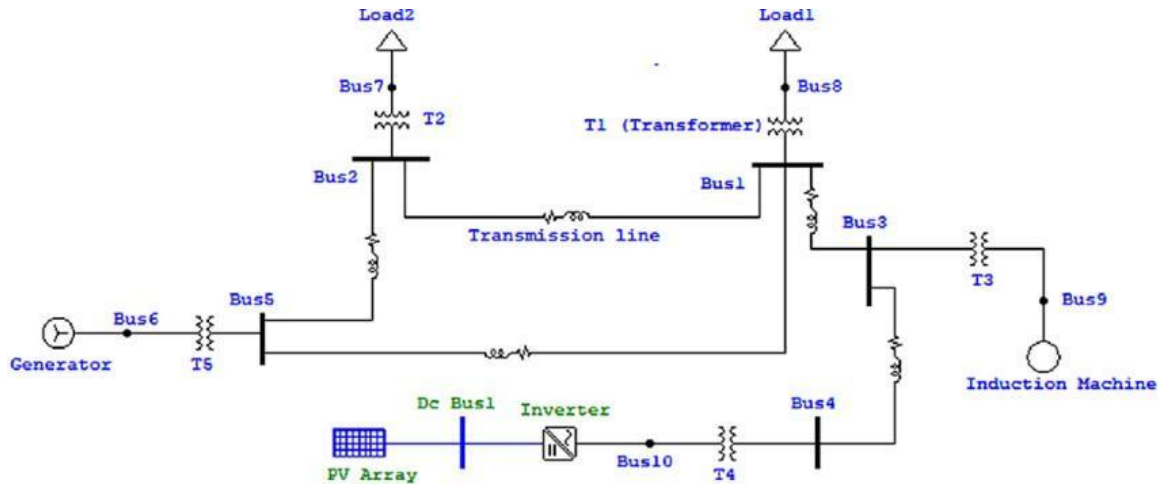

Figure 2.2 A Solar Power System

Table 2.2 Comparative overview of stand-alone and grid-tied systems

Feature	Stand-alone System	Grid-tied System
Grid Dependency	Fully independent	Relies on grid for backup
Energy Storage	Requires battery bank	Optional or absent
Reliability	High (even during outages)	Dependent on grid stability
Cost	Higher (due to storage requirements)	Lower (minimal storage)
Best Use Case	Remote/unreliable grid areas, critical facilities	Urban areas with stable grids and metering options

2.12 REVIEW OF SIMILAR PROJECTS AND EXISTING INSTALLATIONS

Now we proceed to the third aim of our literature review – we examine similar projects involving the design of stand-alone solar systems and identify the approach generally used. We would take a systematic approach in which we go over two similar projects, and then we outline the method they used in design, grouping this into these subheadings:

- 1) Siting of system.
- 2) Choice and sizing of panels.
3. Sizing of charge controllers.
- 3) Battery system sizing.
- 4) Inverter sizing.
- 5) Cable sizing.
- 6) Key insights/approach.

These two projects will be sufficient to infer some overall considerations that are currently being taken when designing a solar stand-alone system.

2.12.1 Project one: design considerations of stand-alone solar photovoltaic systems – W. Ali et al., 2018

This paper outlined an organized approach in designing stand-alone solar systems. It gives key equations that can be used in the sizing of system components, and the technical considerations to take when designing them.

a) Siting of System

W. Ali et al. (2018), outlined the following points to be carefully considered when locating a suitable site for the panels.

- 1) Orientation and direction of the site to be selected (to ensure as much sunlight as possible is gotten from the panels).
- 2) The total available land area of the site under consideration.
- 3) Possible routes for wiring from the site of panels to the site of battery and inverter.
- 4) Type and structure of roof.
- 5) Shade considerations (Locate the site at a point with minimum shade).

b) Choice and sizing of panels

In calculating the size of panels needed, the following points in assessing the amount of solar energy derivable from the panels were mentioned. It was mentioned that they should be “considered cautiously”.

- 1) In calculating for size of panels using the hours of sunlight (H_{sun} as mentioned in equation 2.1), DO NOT use the sun-shine hours. Use the peak-sun hours or insolation.
- 2) Do not make the average annual sun-shine hours equal to the insolation.
- 3) For system design, use the lowest mean daily insolation value from all the days of the year. This ensures that the solar panels will still be able to power the needed load even in periods of minimum sunlight. This is an intelligent approach and a key insight from this article.

Not much mention was made on the factors determining the choice of the type of the panel.

c) Sizing of charge controllers

The article outlines the following:

- 1) The current rating of the charge controller depends on the short-circuit current rating of the solar panels.

$$I_{charge-controller} = I_{sc} \times 1.3 \quad (2.12)$$

- 2) The voltage rating is the same as the nominal voltage of the battery system.

d) Battery system sizing

Speaking on the type of battery system, it was stated that the lead-acid battery was commonly used because of these reasons:

- 1) Availability.
- 2) Cost-effectiveness.
- 3) Lifespan/longevity.

To select and size the batteries, the following factors to consider were mentioned:

- 1) Total load.
- 2) Size and efficiency of inverter.
- 3) Depth of Discharge (DoD).
- 4) Battery nominal value.
- 5) Days of autonomy

The article stated that the days of autonomy (number of cloudy days in a row), is a very important factor to consider. Two alternative equations were given to calculate for the battery capacity, but they didn't explicitly account for the depth of discharge, which we feel is also an important factor.

e) Inverter sizing

The different parameters considered in choosing an inverter were mentioned:

- 1) Cost.
- 2) Reliability.
- 3) Frequency: For instance, in a Nigerian context we operate on a frequency of 50Hz, hence an inverter operating on 60Hz should not be chosen.
- 4) Voltage regulation.
- 5) Efficiency.

The size of the inverter is chosen based on these factors:

- 1) Solar panel output.
- 2) Battery system voltage.
- 3) Peak load demand.

Speaking on the last factor, the output power of the inverter should not just be equal to peak load demand, but more than it. If for instance a motor or compressor is being supplied, it could draw an initial load that is a multiple of its average power, and so a correction factor must be used in sizing the inverter.

$$(VA)_{inverter} = (VA)_{total-load} \times CF \quad (2.13)$$

Where CF is the correction factor for safety. Having a value of 1.25 for regular loads, and 3 for motor loads.

This concept can also be expressed as:

$$Inverter\ Size\ (W) = Total\ Load \times Safety\ Factor \quad (2.14)$$

f) Cable sizing

Discussing on cable sizing, two goals are set:

- 1) Minimize voltage drop.
- 2) Minimize I²R losses.

The expression for cable size was given in terms of the maximum permissible voltage drop, and the measured length of cable required to supply power to load.

g) Key insights/approach

This project intelligently mentioned the need not to use average sun-shine hours to calculate the amount of solar energy derivable from the panels. Another key insight was the need to size the solar panels based on the minimum insolation value, to ensure the system can still supply the needed load on days when sunlight is poor.

2.12.2 Project two: Smart design of stand-alone solar pv system for off grid electrification projects – P. Mohanty and T. Muneer, 2014

In this paper, guidelines for sizing and designing of solar power systems for system optimization are presented. The paper also provides detailed guidelines for selecting the battery system, taking into account the need to satisfy energy demand during the night and in cloudy conditions.

a) Siting of System

Some points mentioned in Project One are also mentioned in the Project Two paper. In addition though, the need of performing a survey after selection of the site is mentioned. This is essential so as to collect some input parameters that will enable us perform optimum design. These parameters collected during the survey include:

- 1) Incident solar radiation.
- 2) Ambient temperature (which affects panel efficiency).
- 3) Wind velocity.

By doing a survey, the possibility of any seasonal shading problem can also be checked.

b) Choice and sizing of panels

As a means to determine the capacity of the solar panels, the solar energy resource available must be taken into account. The paper mentioned that the following information should be gotten:

- 1) Number of sunny and overcast (cloudy) days in a year.
- 2) Solar radiation on a horizontal surface.

It was mentioned that since the information gotten is the amount of solar energy on a horizontal surface, the fact that the solar panels tilt on some roofs and are not perfectly horizontal must be taken into account. This is done by introducing a correction factor into the energy calculations.

Apart from the size of panels, factors that affect our choice of the type of panel were mentioned:

- 1) PV electrical characteristics (such as power tolerance).
- 2) PV temperature tolerance.
- 3) PV efficiency, dimensions and weight.
- 4) PV quality requirement, standards and specifications.
- 5) PV module warranties and guarantees.

c) Sizing of charge controllers

Not much mention was made on the sizing of charge controllers in isolation from the inverters.

d) Battery system sizing

In selecting battery size, the article suggested a smart approach involving segregating daytime load from night-time energy requirements. The concept is this – why supply the daytime load requirement from the battery when the solar panel already handles that? Why not use only the nocturnal energy requirements to size your battery, since the battery is only useful at that time? Of course, consideration must still be made for cloudy days and fluctuations during the day, so correction factors are added.

Days of autonomy are still accounted for in this method, as well as the Depth of Discharge (DoD).

This smart approach also affects the sizing of the panels. Instead of sizing the panels to supply general energy requirements, the capacity of the panels can be instead split into two:

- 1) Capacity required to supply daytime loads.
- 2) Capacity required to charge the battery.

The paper further gave guidelines on the selection of the type of the battery. The following characteristics to consider were mentioned:

- 1) High charging current capability.
- 2) Cycle life and temperature.
- 3) Battery Ah efficiency.
- 4) Good reliability under deep discharge conditions.
- 5) Low cost per Ah.
- 6) Low self-discharge rate.
- 7) Wide operating temperature,
- 8) High recharge efficiency.
- 9) Good power density.

e) Inverter sizing

To size the inverter, three steps were given:

- 1) Calculate the total connected AC load.
- 2) Rate the output capacity of the inverter to be the nearest highest value to the total connected load, such that: *Capacity or rating of inverter \geq total connected AC Load*

Many different factors affecting the choice of the specific inverter were mentioned. A few are:

- 1) AC voltage and frequency range.

- 2) DC voltage range.
- 3) AC harmonic current from inverter.
- 4) Conversion efficiency.
- 5) Operational environment (including temperature requirements).
- 6) Standby power consumption: For a stand-alone solar power system, we definitely would not want the inverter to consume much power from the PV panels even when it is not supplying load.
- 7) Inverter cost.
- 8) Inverter size and weight.

f) Cable sizing

For system optimization, it was mentioned that wiring be designed to minimize voltage drop.

g) Key insights/approach

Several beautiful takeaways were gotten in the review of this paper. The project outlined how the tilt of the panels must be taken into consideration when performing solar energy availability calculations. It mentioned many factors affecting the choice of the particular product to choose when deciding on PV panels, batteries and inverters to use. The intelligent approach of separating daytime load from nocturnal load when sizing both the panels and the batteries was also a key takeaway.

2.12.3 Overall considerations in the design of stand-alone solar systems

As can be seen from the above review of literature, there are some key considerations that are made when designing solar power systems.

Safety: Correction factors must be added when sizing inverter systems to prevent overload damage when inductive loads are started. Also, in sizing the cables, the I^2R losses must be reduced to prevent heating and fire risks.

Reliability: The system we design must be able to supply peak demand even in periods of low sunlight. For this reason, many factors such as days of autonomy and minimum solar

insulation must be taken into account. Our system must be able to serve its purpose – it should supply power.

Cost: An important consideration in the design is cost. Cost determines whether we choose an inverter system with very high efficiency or one with slightly lower efficiency but cheaper cost. Cost determines the trade-offs we make.

It is also noted that cable sizing is done so as to minimize I²R losses, and to do this effectively, one must first calculate the current delivered through the cable. For a three-phase system, this is given by

$$I = \frac{P}{\sqrt{3} \times V \times pf} \quad (2.15)$$

Where,

P = Power delivered in Watts,

I = current in amps,

V = Line-to-line voltage,

pf = Power factor

We have achieved the aims of our literature review. Now, we proceed to the methodology of our project.

CHAPTER 3

METHODOLOGY

3.1 DESIGN CONSIDERATION AND ANALYSIS

In this chapter, we analyse the decisions and considerations made in designing the solar power system.

a) Design considerations

These are the important factors and conditions that must be taken into account in the design, they are given below.

- 1) Geographical location: The system is installed in the University of Benin, Faculty of Engineering. This is important because the location determines certain constants such as:
 - i. Average peak sun hours: Average number of hours per day during which sun light is strong enough to be useful. Sun hours, also called peak sun hours, refer to the equivalent number of hours per day during which solar irradiance averages 1,000 watts per square meter (W/m^2) — the standard for full sunlight used in solar panel ratings.

In this case average peak sun hours = 5.6 hours per day (Mercury Direct, 2023). We round down to 5 hours.

- ii. Ambient temperature: Solar panels and batteries are sensitive to temperature.
 - iii. Generally, higher temperatures leads to decrease in efficiency.
 - iv. Wind direction and speed: Affects the mounting structure and angle.
 - v. Latitude and tilt angle: The angle at which the earth is tilted is important to optimize sunlight. In this case, no tilt is needed (because we are near the equator).
 - vi. Dust and air pollution: Dust settling on panel surfaces reduces efficiency. During the harmattan season, dust becomes a problem, a sprinkler might be necessary.
- 2) System type: In a stand-alone solar power system, the system will not charge from the grid or send excess power to it. But in cases of low solar power, the buildings served can also switch to grid power or any other power source.

- 3) **Autonomy:** This is the number of days the system can deliver power without sunlight.

3.2 LOAD ESTIMATION AND ANALYSIS

This is a detailed analysis of the electrical power consumption of the served area. The data given here were obtained by careful inspection of each area to be served by the solar power system.

a) Ratings Of Each Appliance

- 1) Ceiling fan – 165 W
- 2) Socket (13 amps) – 200 W
- 3) Estimated load for an office – 500 W
- 4) Printers – 100 W
- 5) Refrigerators – 100 W
- 6) Bulbs – 40 W
- 7) LED ceiling light – using an estimate of 18 W
- 8) Speakers – 200 W

b) Load Factors

- 1) Bulb – 0.9
- 2) Socket – 0.6
- 3) Fans – 0.9
- 4) Printers/Photocopiers – 0.4
- 5) Refrigerators – 0.8
- 6) Speakers – 0.2

3.2.1 LOAD ESTIMATION TABLE FOR THE FACULTY OF ENGINEERING

This table consists of the total power consumption in kilowatt, and the total daily energy used in watt hour per day of each type of appliance in the faculty. This data was gotten by a series of careful survey carried out by the project students.

Recall equations 2.4 and 2.5

$$\text{Total Rated Power (kW)} = \text{Power (kW)} \times \text{Quantity} \quad (2.4)$$

$$\text{Average Power} = \text{Total Rated Power} \times \text{Load Factor} \quad (2.5)$$

TABLE 3.1 LOAD ESTIMATION TABLE FOR THE FACULTY OF ENGINEERING

Appliance	Quantity	Power (kW)	Load Factor	Total Rated Power (kW)	Average Power (kW)
SOCKETS	1,799	0.2	0.6	359.8	215.88
SPEAKERS	5	0.2	0.2	1.0	0.2
BULBS	1,423	0.04	0.9	56.92	51.23
FANS	447	0.165	0.9	73.755	66.38
FLUORESCENT BULBS	6	0.2	0.9	1.2	1.08
100W LED LIGHTS	2	0.1	0.9	0.2	0.18
TOTAL	3,282	–	–	492.875	334.95

The total daily consumption is $334,947.5 \text{ W} \times 24\text{hrs} = 8038.74$ kilowatts hour per day, peak load is 492.875 kilowatts.

3.3 INVERTER SIZING

As mentioned in the literature review, inverter sizing depends on the Total Load (kW), which is obtained by adding up the peak power ratings (W) of all appliances.

This project requires us to design two solar power systems, one with a 300kW capacity and another with a 10kW capacity (for select loads). We will track both separately, one after the other.

Recall equation 2.14

$$\text{Inverter Size (W)} = \text{Total Load} \times \text{Safety Factor} \quad (2.14)$$

A safety factor is added to make sure the inverter can handle unexpected load surges.

Safety factor = 1.25 (Votmatic Energy Solutions, 2024).

We have been given a fixed value of 300kW for the inverter size, so we will calculate for the total load:

$$\text{Total load} = 300 \text{ kW} / 1.25 = 240 \text{ kW}$$

This is the total load the solar power system can power.

The inverter chosen has a 300 kW capacity and a DC input rated voltage of 480V.

3.4 LOAD SEPARATION

From the previous sections, the peak load estimated is more than the inverter capacity, so the system will be unable to power all the loads in the faculty at all times. Therefore, we will need to carry out load separation.

Load separation is the process of dividing electrical loads into groups or separate circuits based on priority, their type, or location.

a) IMPORTANCE OF LOAD SEPARATION

- 1) It prevents overloading of the power system at any point in time.
- 2) It helps to save cost, i.e, money need not be wasted on inverters of higher capacity.
- 3) It helps to prioritize essential loads over the non-essentials.

b) LOAD SEPARATION METHOD

The total load is divided into two groups: essential load and secondary load. The essential loads are removed from their former distribution board and connected to a new distribution board which is supplied by the inverter. This ensures that non-essential loads are not supplied by the inverter system. This concept is illustrated with the diagrams below:

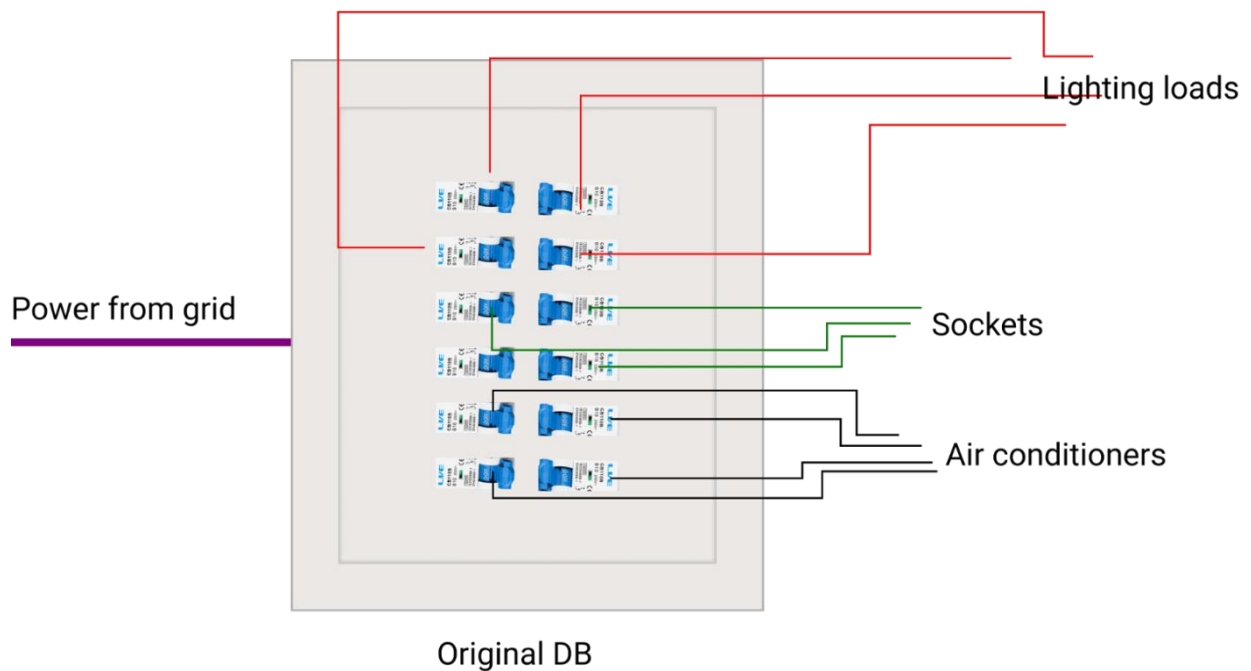

Figure 3.1 Original DB

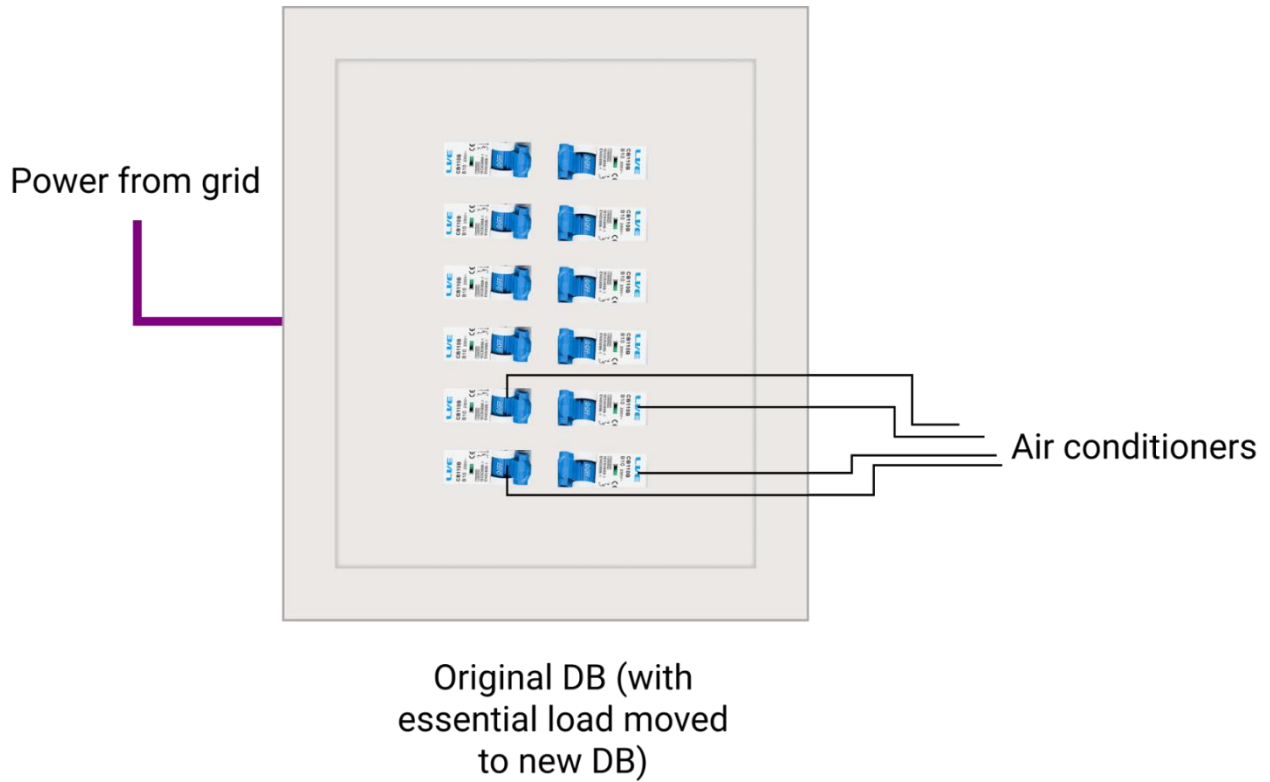

Figure 3.2 Original DB (with essential load moved to new DB)

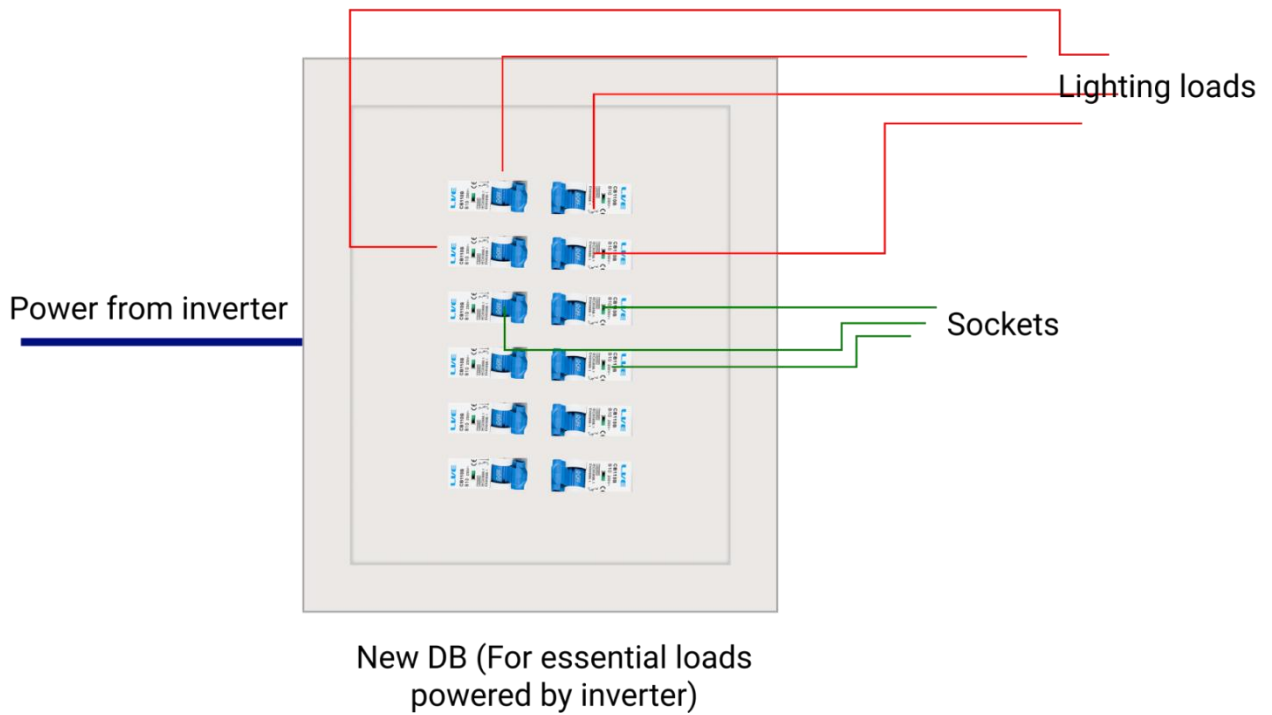

Figure 3.3 New DB (For essential loads powered by inverter)

3.4.1 LOAD CENTERS AND CABLE LENGTHS OF THE DISTRIBUTION NETWORK IN ENGINEERING

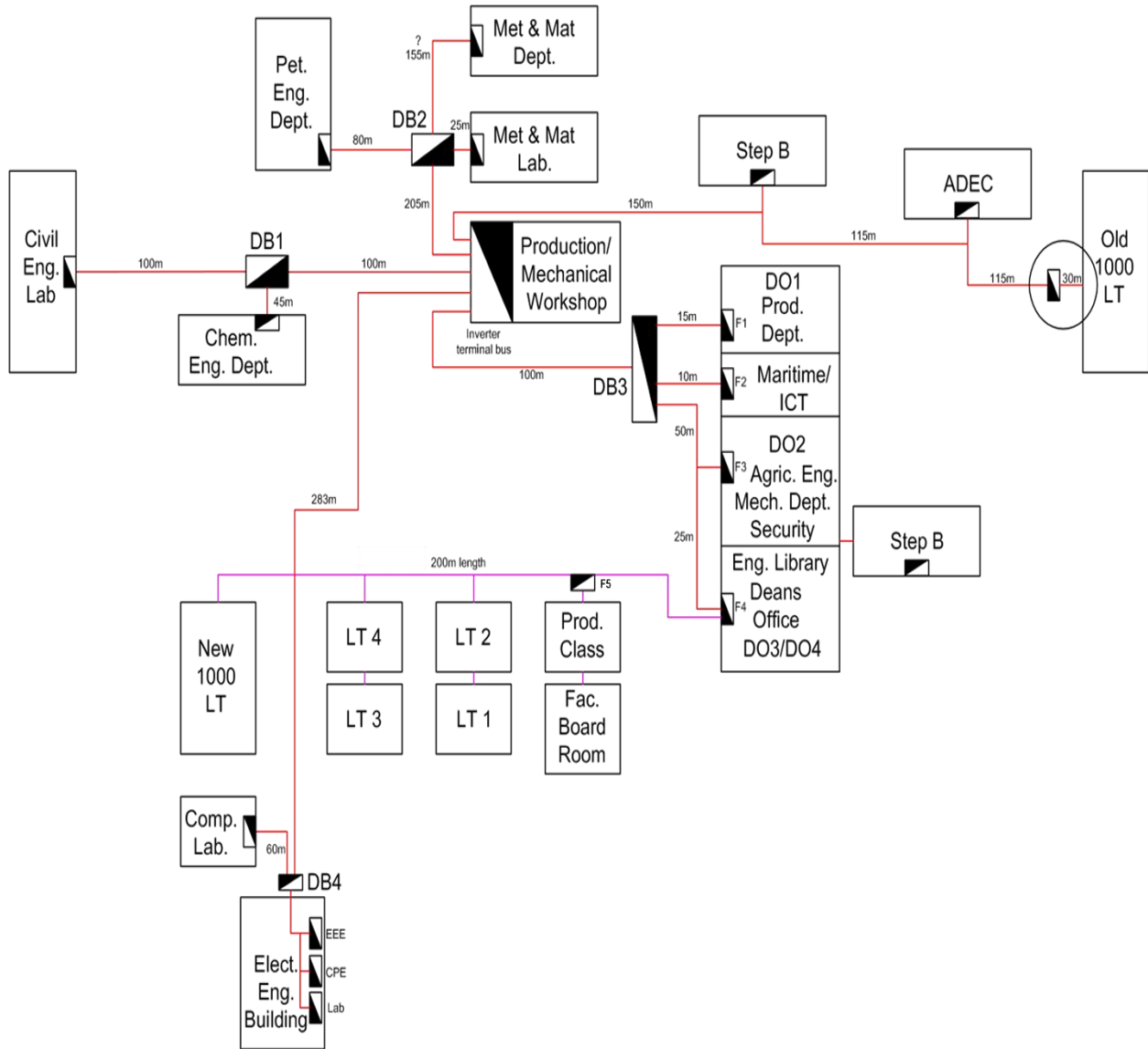

Figure 3.4 Load Centers and Cable Lengths of the Distribution Network in Engineering

3.4.2 LOAD SEPARATION FOR 300kW POWER SYSTEM

240kW is the maximum safe peak power output; the goal is to divide the total load into essential and secondary, with the essential loads connected to the new distribution board. The essential loads include lighting loads, sockets and fans, while all other loads are considered as secondary loads. The essential loads should be within this safe peak power output.

Table 3.2: THE LOAD FOR EACH LOCATION IN THE FACULTY

LOCATION	PEAK LOAD (KW)
ELECTRICAL CAR PARK	0.540
FACULTY CAR PARK	0.810
DO1	6.102
DO2	6.822
DO3	8.970
DO4	4.662
LIGHT BULBS OUTSIDE DO1-DO4	1.152
CHEMICAL ENGINEERING	35.102
CIVIL ENGINEERING	68.924
CPE LAB	18.325
NEW 1000LT BUILDING	25.442
OLD 1000LT	14.748

MARITIME	12.816
SECURITY WING	2.685
LIBRARY WING	4.423
DEAN'S OFFICES	5.088
MECHANICAL DEPARTMENT OFFICES	11.748
PRODUCTION DEPARTMENT OFFICES	4.992
LT1	6.276
LT2	3.726
LT3	3.366
LT4	3.510
ELECTRICAL BUILDING	67.681
STEP B / IDE FOUNDRY	4.626
PETROLEUM ENGINEERING	21.810
FACULTY WORKSHOP	30.126
MET AND MAT BUILDING 1	35.433
MET AND MAT BUILDING 2	29.838
ADEC	28.422
TOTAL	468.17

As seen from Table 3.2 above, the total essential load in the faculty still exceeds the maximum safe peak power output of the system being designed. Hence, we will need to isolate some load by giving priority to certain essential load in some locations over others pending when there is an expansion of the system to accommodate all essential load, or possibly to single-handedly power the entire faculty. The isolated load and final load for each location is shown in Table 3.3 below

Table 3.3 THE ISOLATED LOAD FOR EACH LOCATION IN THE FACULTY

LOCATION	PEAK LOAD (kW)	ISOLATED LOAD(kW)	FINAL LOAD(kW)
ELECTRICAL CAR PARK	0.540	0	0.540
FACULTY CAR PARK	0.810	0	0.810
DO1	6.102	2.519	3.583
DO2	6.822	3.960	2.862
DO3	8.970	7.082	1.888
DO4	4.662	1.802	2.860
LIGHT BULBS OUTSIDE DO1-DO4	1.152	0	1.152
CHEMICAL ENGINEERING	35.102	12.469	22.633
CIVIL ENGINEERING	68.924	41.839	27.085
CPE LAB	18.325	16.411	1.913
NEW 1000LT BUILDING	25.442	14.280	11.162
OLD 1000LT	14.748	8.315	6.433
MARITIME	12.816	12.816	0

SECURITY WING	2.685	1.919	0.766
LIBRARY WING	4.423	1.440	2.983
DEAN'S OFFICES	5.088	5.088	0
MECHANICAL DEPARTMENT OFFICES	11.748	9.480	2.268
PRODUCTION DEPARTMENT OFFICES	4.992	3.840	1.152
LT1	6.276	6.276	0
LT2	3.726	3.726	0
LT3	3.366	3.366	0
LT4	3.510	3.510	0
ELECTRICAL BUILDING	67.681	27.600	40.080
FACULTY BOARD ROOM	3.335	3.335	0
STEP B / IDE FOUNDRY	4.626	0	4.626
PETROLEUM ENGINEERING	21.810	8.040	13.770
FACULTY WORKSHOP	30.126	15.959	14.167
MET AND MAT BUILDING 1	35.433	19.438	15.995
MET AND MAT BUILDING 2	29.83	17.761	12.078
ADEC	28.422	25,200	3.222
TOTAL			194.03

3.4.3 LOAD SEPARATION FOR 10kW POWER SYSTEM

In this power system, 8kW is the maximum safe peak power output. The goal is to divide the total load into essential and secondary, just like before. The essential load should be within this safe peak power output. The locations to be powered by this system are shown in the table below.

Table 3.4 THE LOAD FOR EACH LOCATION

LOCATION	PEAK LOAD (kW)
LT 1	6.276
LT 2	3.725
LT 3	3.366
LT 4	3.51
Board room	3.335
Deans office	5.088

We will now isolate some of the load from others in order for the total load to fall below 8kW.

We split the load for every location (except the faculty board room) thus:

- Essential load: Light Bulbs
- Non-Essential loads: Fans, sockets, etc.

For the faculty board room:

- Essential load: Light bulbs and fans

- Non-Essential loads: Sockets

The load isolation is carried out physically on the distribution board in each location (i.e, the appliances grouped as non-essential will be electrically isolated from the inverter in the distribution board).

Table 3.5 THE ISOLATED LOAD FOR 10kW SYSTEM

LOCATION	PEAK LOAD (kW)	ISOLATED LOAD(kW)	FINAL LOAD(kW)
LT 1	6.276	5.628	0.648
LT 2	3.725	3.113	0.612
LT 3	3.366	2.753	0.613
LT 4	3.510	2.754	0.756
Faculty board room	3.335	1.600	1.736
Dean's office	5.088	3.720	1.368
Total			5.733

3.5 Battery Sizing

Using equation 2.9 and 2.10

$$\text{Required Battery Capacity (Wh)} = \frac{\text{Average Load} \times \text{Autonomy}}{\text{DoD} \times \text{Efficiency}} \quad (2.9)$$

$$\text{Average Load} = \text{Peak Load} \times \text{Load Factor} \quad (2.10)$$

a) BATTERY SIZING FOR THE 300kW SYSTEM

Peak load = 194.03 kW (from load separation)

Average load = peak load × load factor

Given average load factor = 0.5

The justification for this low load factor comes from the fact that the battery is meant to supply nighttime loads since the panels are already properly sized to provide enough power during the day. The location under consideration (the faculty of engineering) is one whose peak load is during the day, and the load dips at night.

Therefore,

Average load = 194 × 0.5

= 97 kW

Days of autonomy = Out-of-office time (6pm – 8am) = 14 hrs

Depth of discharge = 90% (LiFePO₄ battery)

Efficiency = 92%

$$\text{Required Battery Capacity (Wh)} = \frac{\text{Average Load} \times \text{Autonomy}}{\text{DoD} \times \text{Efficiency}}$$

$$\text{Required Battery Capacity (kWh)} = \frac{97 \times 14}{0.9 \times 0.92}$$

= 1640.1 kWh

To know the number of parallel connections needed for the battery, we need to find the Ah rating of the battery.

From equation 2.8,

$$Q = \frac{\text{Energy}}{V} \quad (2.8)$$

And using a battery bank of 480V (DC input of inverter)

$$Q = 1640.1 \times 1000 \text{ Wh} / 480$$

$$= \mathbf{3416.9Ah}$$

The battery unit we use for our design has a capacity of 51.2V and 2000Ah (100kWh).

No of series connections = $480V / 51.2V = 9.3 \approx 9$ (We can round down since the capacity will still be met because we round up the number of parallel paths)

No of parallel paths = Total Ah capacity / Ah capacity of one unit

$$= 3416.9 / 2000 = 1.71, \text{ rounded up to } 2$$

Total number of battery units required = $9 \times 2 = \mathbf{18 \text{ units of } 100kWh \text{ batteries}}$

b) BATTERY SIZING FOR THE 10kW SYSTEM

Peak load = 5.733 kW (From load separation)

Average load = peak load × load factor

Given average load factor = 0.5

Average load = 5.733 × 0.5

= 2.8665 kW

Days of autonomy = Out-of-office hours (6pm – 8am) = 14 hrs

Depth of discharge = 90% (LiFePO₄ battery)

Efficiency = 92%

$$\text{Required Battery Capacity (Wh)} = \frac{\text{Average Load} \times \text{Autonomy}}{\text{DoD} \times \text{Efficiency}}$$

$$\text{Required Battery Capacity (kWh)} = \frac{2.8665 \times 14}{0.9 \times 0.92} = 48.47 \text{ kWh}$$

Required Battery Capacity (kWh) = 48.47 kWh

From equation 2.8,

$$Q = \frac{\text{Energy}}{V} \tag{2.8}$$

And using a battery bank of 51.2V (DC input of inverter)

$$Q = 48.47 \times 1000 \text{ Wh} / 51.2$$

$$= \mathbf{946.68 \text{ Ah}}$$

The battery unit we use for our design has a capacity of 51.2V and 300Ah (15kWh).

$$\text{No of series connections} = 51.2\text{V} / 51.2\text{V} = 1$$

$$\text{No of parallel paths} = \text{Total Ah capacity} / \text{Ah capacity of one unit}$$

= 946.68 / 300 = 3.16, rounded to 3 (We can round down since rounding up will give us far more capacity than required)

Total number of battery units required = $3 \times 1 = 3$ **units of 15kWh batteries in parallel**

As a means of balancing cost considerations with demand for uninterrupted power, 2 units of batteries can be used instead, as daytime load will still be assured.

3.6 PV ARRAY SIZING

Using equation 2.6:

$$\text{Peak array power}(kW) = \frac{\text{Daily energy consumption (kWh/day)}}{\text{Peak sun hours}(h) \times \text{efficiency}} \quad (2.6)$$

a) PV ARRAY SIZING FOR THE 300 KW SYSTEM

Daily energy = Daytime energy + Out-of-office-hours energy

From the load isolation, the peak load is $248.7543 \times 0.78 = 194$ kW

Daytime energy during office hours (8am-6pm) = 194×0.85 (load factor) $\times 10$ hours
= 1649 kWh

Out-of-office-hours energy (6pm-8am) = 194×0.5 (load factor) $\times 14$ hours
= 1358 kWh

Daily energy = 1649 kWh + 1358 kWh
= 3007 kWh/day

Peak sun hours = 5 hrs

Efficiency = 85 percent

$$\text{Peak array power (kw)} = \frac{3007}{5 \times 0.85}$$
$$= 707.53 \text{ kW}$$

Number of Solar Panels

Assume use of 800W panels, 120V

Number of Panels = Peak array power / power rating of one solar panel

$$\frac{707.53 \times 1000}{800} = 885 \text{ panels}$$

Number of series connections = Total inverter DC input / Voltage rating of one panel

$$= 480\text{V} / 48\text{V}$$

$$= 10 \text{ series connections}$$

Number of parallel connections = Total number of panels / Number of series connections

$$= 885 / 10$$

$$= 88.5 \text{ parallel connections}$$

We round up to be able to meet the required capacity, so we have **89** parallel paths

The total number of panels needed = $89 \times 10 = \mathbf{890 \text{ panels}}$

b) PV ARRAY SIZING FOR THE 10 kW SYSTEM

Daily energy = Daytime energy + Out-of-office-hours energy

From the load isolation, the peak load is $7.35 \times 0.78 = 5.733\text{kW}$

Daytime energy during office hours (8am-6pm) = 5.733×0.9 (load factor) $\times 10$ hours

$$= 51.6 \text{ kWh}$$

Out-of-office-hours energy (6pm-8am) = 5.733×0.5 (load factor) $\times 14$ hours

$$= 40.131 \text{ kWh}$$

Daily energy = $51.6 \text{ kWh} + 40.131 \text{ kWh}$

$$= 91.731 \text{ kWh/day}$$

Peak sun hours = 5 hrs

Efficiency = 85 percent

$$\begin{aligned}\text{Peak array power (kw)} &= \frac{91.731}{5 \times 0.85} \\ &= 21.6 \text{ kW}\end{aligned}$$

Number of Solar Panels

Assume use of 600W panels, 52V

$$\begin{aligned}\text{Number of Panels} &= \text{Peak array power} / \text{power rating of one solar panel} \\ &= 21.6 \times 1000 / 600 = 36 \text{ panels}\end{aligned}$$

$$\begin{aligned}\text{Number of series connections} &= \text{Total inverter DC input} / \text{Voltage rating of one panel} \\ &= 51.2 \text{ V} / 52 \text{ V} \\ &= 0.98 \text{ series connections} \\ &\approx 1 \text{ series connections}\end{aligned}$$

$$\begin{aligned}\text{Number of parallel connections} &= \text{Total number of panels} / \text{Number of series connections} \\ &= 36 / 1 \\ &= 36 \text{ parallel connections}\end{aligned}$$

The total number of panels needed = **36 panels in parallel**

3.6.1 PV ARRAY CAPACITY SIMULATION AND ERROR CALCULATION

In order to ensure that the calculated number of panels for the PV array and its arrangement actually meets the power requirements, a simulation of the PV array was carried out in MATLAB (and engineering simulation software) to mimic real life operation of the panels

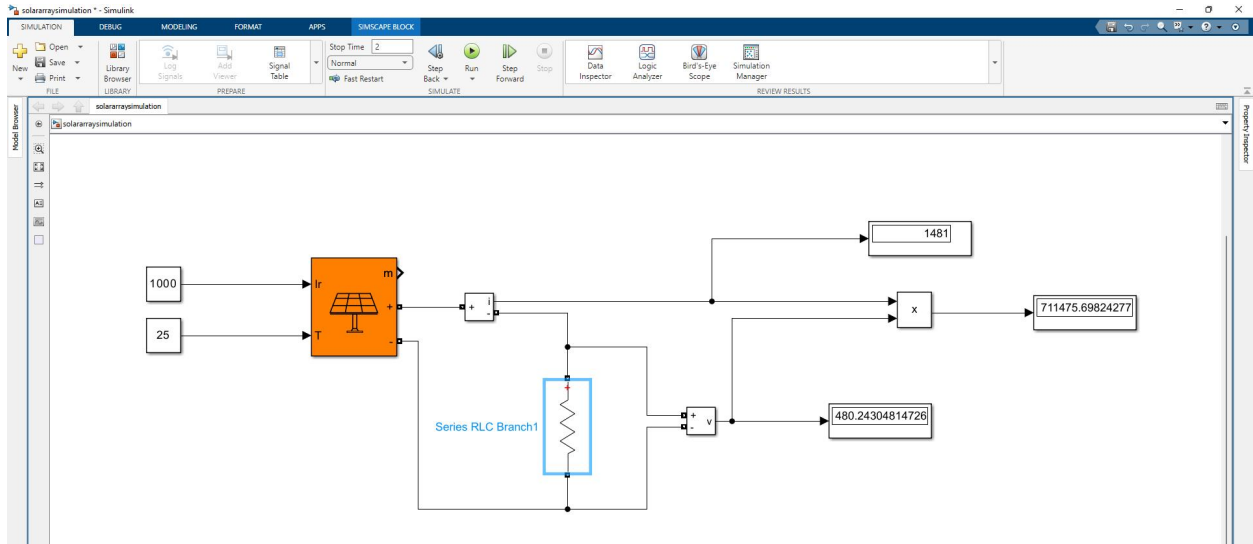

Figure 3.5 MATLAB Simulation of PV Array Capacity

After running the simulation, using the values of number of PV cells, number of parallel paths, number of series paths, power of a single cell, solar irradiation and ambient temperature gotten from our calculations, an output power of 711475.698 Watts was obtained which is very close to the previously calculated value of 707530 watts. This ascertains that indeed the calculated number of panels and its arrangement in our calculations can sufficiently provide the required peak power.

Given slight difference in the simulated and calculated values, we have to calculate the value of the difference (error)

$$\begin{aligned} \text{Error} &= \frac{\text{simulate value} - \text{calculated value}}{\text{simulated value}} \times 100 \\ &= \frac{711475.698 - 707530}{711475.698} \times 100 \\ &= 0.555 \% \end{aligned}$$

The error gotten is 0.555%. This value is very small and has no effect on the system and as such will be neglected.

3.7 CHARGE CONTROLLER SIZING

Charge controller sizing involves selecting a controller with the correct current (Amps) and voltage ratings to handle the power from the solar panels and match the battery bank. In this project, we will not be carrying out any calculations on the charge controller sizing for our systems because the inverter system is hybrid – that is, it has an in-built charge controller (MPPT type).

3.8 SYSTEM LAYOUT AND CONFIGURATION

Table 3.6 System components and their functions in the solar system design

S/N	COMPONENT	DESCRIPTION/FUNCTION
1.	Solar Panel (PV modules)	Converts the energy trapped from sunlight to DC voltage.
2.	Hybrid Inverter	Converts DC power to AC power.
3.	Lithium Ion Battery	Stores the energy trapped from the sunlight
4.	Charge Controller	Regulates the voltage from PV panels to batteries
5.	AC/DC Breakers	It is used for protection of the system
6.	Wires and Cables	For interconnections within the system
7.	Changeover Switches	It is used to switch the power source

SYSTEM CONFIGURATION (INTERACTION BETWEEN THE COMPONENTS)

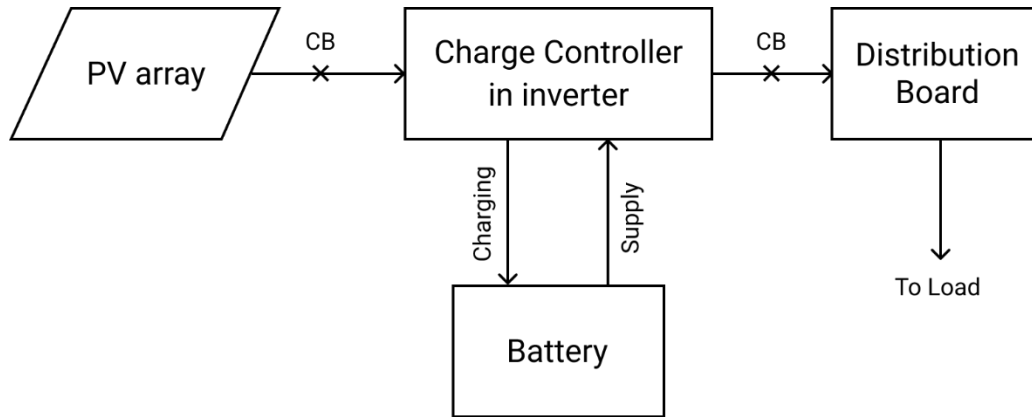

Figure 3.6: System Configuration (Interaction Between The Components)

The operation of the system is divided into three major parts:

- 1) Power generation
- 2) The charging of the battery/storing of energy
- 3) The supply of power to the load.

a) SOLAR PANELS AND CHARGE CONTROLLER:

The PV array generates DC electricity when exposed to sunlight. Strings are connected to a DC combiner box equipped with fuses, and other surge protection devices.

The output voltage from the panels varies based on the intensity of sunlight and specifications of the product; some products output more voltage than others.

However, whatever the panels generate must be within an acceptable range stated on the inverter user manual.

Knowing that the intensity of sunlight is not constant all day, it is obvious that the voltage generated will continually vary with the intensity of sunlight. To regulate this variation, the power generated from the solar panel is made to first pass through the charge controller (which is embedded in the inverter). This helps to ensure that the voltage supplied to the battery for storage is within an acceptable range. This is the only way the system can work smoothly - when the

amount of charge flowing into the system is within the specified operating range of the battery and inverter.

This process makes up the first part of the system operation- storing energy by charging the battery.

b) INVERTER AND BATTERY

The inverter used is a hybrid inverter (i.e. a smart all-in-one inverter) that integrates an MPPT charge controller. By “all-in-one”, we mean DC power regulation, battery management and DC-AC conversion are handled in a single unit. The interaction between the battery and the inverter is two-way;

- 1) When the inverter serves the purpose of power regulation, the interaction starts at the inverter and ends at the battery terminals. Regulated power flows through the inverter to the battery. This is the process by which the battery gets the power it stores.
- 2) When the inverter serves the purpose of a DC-AC converter, the interaction is from the battery to the inverter. The DC power stored in the battery is converted to AC as it passes through the inverter to supply the load. This is the second phase of the system operation.

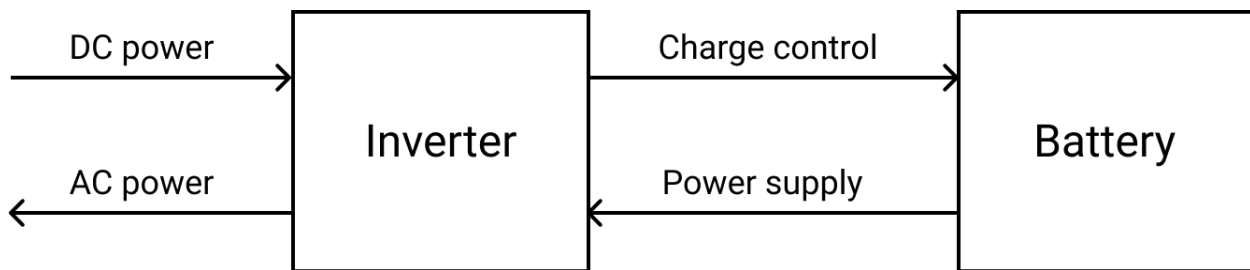

Figure 3.7 Inverter And Battery

c) AC/DC BREAKERS

In cases where high power is generated, there is a possibility of experiencing surges in the supply voltage or current. This may be due to lightning or any other electrical malfunction in the system. The AC/DC breaker regulates this surge by tripping when the power flowing through the system exceeds a nominal range. The breakers are positioned such that one is on the DC side (between

the solar panels and charge controller) and another on the AC side (between the inverter and supply to the load). This way, the system is protected from surges and electrical malfunctions.

d) CHANGEOVER SWITCHES

In the system, the changeover switch is the component that ensures the load is supplied constantly, from either the solar system or the national grid. With the changeover switch in place, the transition between sources is quick and safe. The incorporation of changeover switches guarantees that the solar and generator outputs never connect directly together.

The changeover switch is connected between the inverter output and the distribution board.

e) PHYSICAL LAYOUT

The panels are mounted on the rooftop at the faculty workshop in order to have direct access to sunlight – which is the source of the power. They are inclined at an angle to the horizontal for maximum solar capture. Combiner boxes are placed near the PV array clusters to reduce DC cable losses.

The batteries and inverters are housed in the faculty control room, together with the DC/AC protection panels. This helps to simplify wiring, facilitate maintenance, and improve efficiency of the system. For maximal operation of the system, the room is well-ventilated and equipped with adequate fire protection.

Distribution boards are strategically placed within different buildings/zones in the faculty to serve designated areas.

3.9 CABLE SIZING

To obtain the size of cable required for any electrical connection, we use equation 2.15

$$I = \frac{P}{\sqrt{3} \times V \times pf} \quad (2.15)$$

Where P is the power in watts

V is the line-to-line voltage = 400V

pf is the power factor = 0.78

$$\therefore I = \frac{P}{\sqrt{3} \times 400 \times 0.78} = \frac{P}{540.4}$$

The table below is a chart showing the appropriate cable size for each building and facility in the Faculty of Engineering, University of Benin. The values in this chart were obtained following the standard set by IEC 60364-5-52 (2009), IEC 60287-1-1 (2014), IEC 62548 (2016) and IEC 60364-7-712 (2017).

Table 3.7 Cable Sizing Chart For All Sections in the Faculty of Engineering

LOCATION	CONSUMPTION, P (KW)	CURRENT RATING (A)	CABLE SIZE(mm ²)
		Three-phase $I = \frac{P(Watts)}{540.4}$	Three Phase
ELECTRICAL CAR PARK	0.54	1.0	1.5
FACULTY CAR PARK	0.81	1.5	1.5
DO1	6.102	11.29	1.5
DO2	6.822	12.62	1.5

DO3	8.97	16.6	2.5
DO4	4.662	8.63	1.5
LIGHT BULBS OUTSIDE DO1-DO4	1.152	2.13	1.5
CHEMICAL ENGINEERING	35.1025	64.96	16
CIVIL ENGINEERING	68.9239	127.54	50
CPE LAB	18.3249	33.9	6
NEW 1000LT BUILDING	25.442	47.08	10
OLD 1000LT	14.748	27.29	6
MARITIME	12.816	23.72	4
SECURITY WING	2.685	4.97	1.5
LIBRARY WING	4.4145	8.17	1.5

DEAN'S OFFICES	5.088	9.42	1.5
MECHANICAL DEPARTMENT OFFICES	11.748	21.74	4
PRODUCTION DEPARTMENT OFFICES	4.992	9.24	1.5
LT1	6.276	11.6	1.5
LT2	3.726	6.89	1.5
LT3	3.366	6.22	1.5
LT4	3.51	6.5	1.5
ELECTRICAL BUILDING	67.6935	125.27	50
STEP B / IDE FOUNDRY	4.626	8.56	1.5
PETROLEUM	21.81	40.35	10

ENGINEERING			
FACULTY WORKSHOP	30.126	55.75	16
MET AND MAT BUILDING 1	35.433	65.57	16
MET AND MAT BUILDING 2	29.838	55.21	16
ADEC	28.422	52.59	16
FACULTY BOARD ROOM	3.335	6.17	1.5

POWER DISTRIBUTION LAYOUT IN THE FACULTY OF ENGINEERING

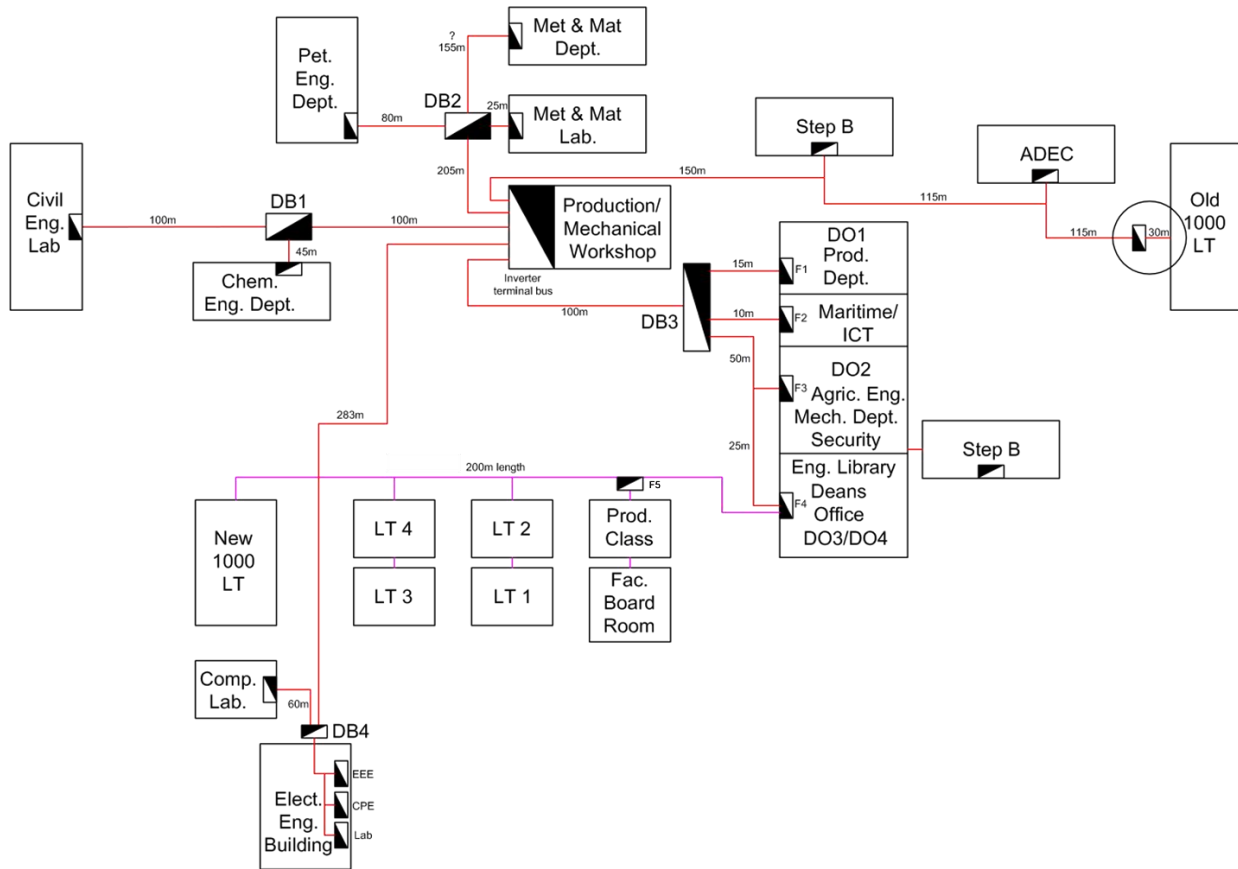
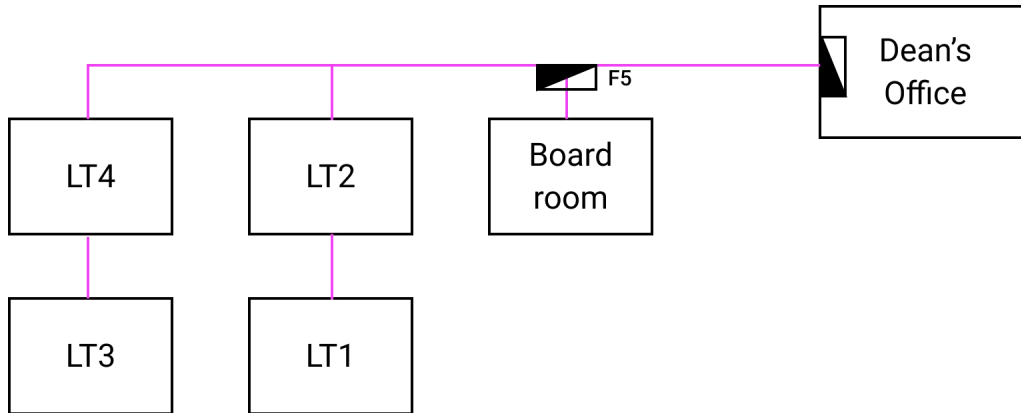

Figure 3.4 Load Centers and Cable Lengths of the Distribution Network in Engineering

Table 3.8 CABLE SIZING CHART FOR 300kW SYSTEM POWER DISTRIBUTION				
NAME OF DISTRIBUTION BOARD	CONNECTED BUILDINGS	TOTAL CURRENT DRAWN (A)	SIZE OF CABLE REQUIRED (mm^2)	
STEP B	STEP B	8.56	1.5	
ADEC	ADEC	52.59	16	
OLD 1000LT	OLD 1000LT	27.29	6	
DB2	1. MET & MAT DEPT	161.14	70	

	2. MET AND MAT LAB 3. PET. ENG. DEPT.		
DB1	1. CHEM. ENG. DEPT 2. CIVIL ENG. LAB	192.95	95
DB4	1. ELECT. ENG. BLDG. 2. COMPUTER LAB	159.17	70
F1	1. DO1 2. PROD. DEPT.	20.53	2.5
F2	1. MARITIME 2. ICT	23.71	4
F3	1. DO2 2. AGRIC. ENG. 3. MECH. DEPT. 4. SECURITY	39.34	10
F5	1. FACULTY BOARD ROOM 2. LT1 3. LT2 4. LT3 5. LT4 6. NEW 1000LT	84.48	25
F4	1. ENG. LIBRARY 2. DEAN'S OFFICE 3. DO3 4. DO4 5. F5	127.29	50
DB3	1. F1 2. F2 3. F3 4. F4 5. F5	278.12	185

POWER DISTRIBUTION LAYOUT FOR 10kW SYSTEM



NAME OF DISTRIBUTION BOARD	CONNECTED BUILDINGS	TOTAL CURRENT DRAWN (A)	SIZE OF CABLE REQUIRED (mm²)
F5	1. FACULTY BOARD ROOM 2. LT1 3. LT2 4. LT3 5. LT4	37.40	10
DEAN'S OFFICE	DEAN'S OFFICES	9.415	1.5

Figure 3.8: Power Distribution Layout for 10kW System

3.10 CIRCUIT BREAKER SIZING

In the 300 kW solar photovoltaic (PV) system designed for the Faculty of Engineering, circuit breakers are installed in the new distribution boards where the load to be powered by the photovoltaic system are now connected. The selection and sizing of each circuit breaker are

based on parameters such as rated voltage, current capacity, and prospective short-circuit current, in accordance with International Electro-technical Commission (IEC) 60947-2 (2016), 60898-1 (2015), and IEC 60364-4-41 (2005) standards.

This section outlines the ratings and selection criteria of the circuit breakers employed in the system, ensuring proper coordination, operational reliability, and effective protection under all expected conditions.

a) STEPS TAKEN TO OBTAIN SIZE OF CIRCUIT BREAKERS IN THE DISTRIBUTION BOARDS

1. Calculate the continuous AC current (per phase) using equation 2.15
2. Design using a standard continuous-load multiplier of 125% of the continuous current (i.e. multiply by 1.25) to account for thermal rise and continuous operation.
3. Select the nearest standard breaker rating \geq the 125% design current (IEC 60898/60947-2).
4. Check the breaker interrupting capacity (kA) to ensure that the breaker chosen has a fault-breaking rating (kA) \geq PSCC (Prospective Short-Circuit Current) with margin (IEC 60364-5-52).
5. Cable sizing: Check cable ampacity tables to ensure chosen cable ampacity \geq design current after applying derating factors such as ambient temperature, grouping, insulation type, installation method (IEC 60364-5-52). Check voltage drop to ensure it is within allowable percentage ($\leq 3\%$ for branch circuits and $\leq 5\%$ for final circuits).

Table 3.10 CIRCUIT BREAKER SIZING FOR MAINS TO DISTRIBUTION BOARDS				
S/N	NAME OF DISTRIBUTION BOARD	TOTAL CURRENT DRAWN (A)	1.25 × LOAD (A)	SIZE OF CIRCUIT BREAKER REQUIRED (A)
1.	STEP B	8.56	10.70	16
2.	ADEC	52.59	65.74	80
3.	OLD 1000LT	27.29	34.11	40
4.	DB2	161.14	201.42	250
5.	DB1	192.95	241.19	250
6.	DB4	159.17	198.96	200
7.	F1	20.53	25.66	32
8.	F2	23.71	29.64	32
9.	F3	39.34	49.18	50
10.	F5	84.48	105.60	125
11.	F4	127.29	159.11	160
12.	DB3	210.87	263.59	300

Table 3.11 SIZE OF CIRCUIT BREAKERS IN STEP B DISTRIBUTION BOARD						
BREAKER	LOCATION	CONNECTED LOAD	CONSUMPTION (kW)	CURRENT (A)	CURRENT × 1.25	BREAKER SIZE (A)
B1	FOUNDRY	Sockets	0.6	1.11	1.387	3
B2	WORKSHOP/ STEP B	100W LED lights and Bulbs	0.504	0.933	1.166	3
B3		Surrounding lights	0.36	0.666	0.833	3
B4	INDUSTRIAL	Sockets	0.84	1.554	1.943	3
B5	ENG.	Bulbs	0.54	0.999	1.25	3
B6	WORKSHOP	Fans	1.782	3.298	4.123	6

Table 3.12 SIZE OF CIRCUIT BREAKERS IN ADEC DISTRIBUTION BOARD						
BREAKER	LOCATION	CONNECTED LOAD	CONSUMPTION (kW)	CURRENT (A)	CURRENT × 1.25	BREAKER SIZE (A)
B1	COMPUTER HALLS 1 & 2	Sockets	23.28	43.08	53.85	60
B2		Bulbs	2.016	3.731	4.664	6
B3	OFFICES	Sockets	1.92	3.553	4.441	6
B4		Bulbs	0.144	0.266	0.333	3
B5		Fan	0.594	1.099	1.374	3
B6	OUTSIDE LIGHT	Bulbs	0.468	0.866	1.083	3

Table 3.13 SIZE OF CIRCUIT BREAKERS IN OLD 1000LT DISTRIBUTION BOARD						
BREAKER	LOCATION	CONNECTED LOAD	CONSUMPTION (kW)	CURRENT (A)	CURRENT × 1.25	BREAKER SIZE (A)
B1	OLD 1000LT	Sockets	3.84	7.105	8.881	10
B2		Bulbs	2.592	4.796	5.995	6
B3		Fans on left wing	4.158	7.694	9.618	10
B4		Fans on right wing	4.158	7.694	9.618	10

Table 3.14 SIZE OF CIRCUIT BREAKERS IN DISTRIBUTION BOARD 1						
BREAKER	LOCATION	CONNECTED LOAD	CONSUMPTION (kW)	CURRENT (A)	CURRENT × 1.25	BREAKER SIZE (A)
B1	CHEMICAL ENGINEERING		35.1025	64.96	81.2	100
B2	CIVIL ENGINEERING		68.9239	127.54	159.43	200

Table 3.15 SIZE OF CIRCUIT BREAKERS IN DISTRIBUTION BOARD 2						
BREAKER	LOCATION	CONNECTED LOAD	CONSUMPTION (kW)	CURRENT (A)	CURRENT × 1.25	BREAKER SIZE (A)
B1	MET AND MAT BUILDING 1		35.433	65.57	81.96	100
B2	MET AND MAT BUILDING 2		29.838	55.21	69.01	100
B3	PETROLEUM ENG. DEPT.		21.81	40.35	50.44	60

Table 3.16 SIZE OF CIRCUIT BREAKERS IN DISTRIBUTION BOARD 3						
BREAKER	LOCATION	CONNECTED LOAD	CONSUMPTION (kW)	CURRENT (A)	CURRENT × 1.25	BREAKER SIZE (A)
B1	DB F1		11.094	20.53	25.66	32
B2	DB F2		12.816	23.71	29.64	32
B3	DB F3, F4, F5		90.046	166.63	208.29	250

Table 3.17 SIZE OF CIRCUIT BREAKERS IN DISTRIBUTION BOARD 4						
BREAK ER	LOCATIO N	CONNECT ED LOAD	CONSUMPTI ON (kW)	CURRE NT (A)	CURRE NT × 1.25	BREAK ER SIZE (A)
B1	ELECTRIC AL BUILDING		67.6935	125.27	156.59	200
B2	CPE LAB		18.3249	33.9	42.38	60

Table 3.18 SIZE OF CIRCUIT BREAKERS IN DISTRIBUTION BOARD F1						
BREAK ER	LOCATI ON	CONNECT ED LOAD	CONSUMPTI ON (kW)	CURRE NT (A)	CURRE NT × 1.25	BREAK ER SIZE (A)
B1	DO1		6.102	11.29	14.11	16
B2	PROD. DEPT.		4.992	9.24	11.55	16

Table 3.19 SIZE OF CIRCUIT BREAKERS IN DISTRIBUTION BOARD F2						
BREAKER	LOCATION	CONNECTED LOAD	CONSUMPTION (kW)	CURRENT (A)	CURRENT × 1.25	BREAKER SIZE (A)
B1	MARITIME CLASSES AND OFFICES	Sockets	4.44	8.216	10.27	16
B2		Bulbs	0.504	0.933	1.17	3
B3		Fans	1.039	1.923	2.4	3
B4	MARITIME	Sockets	4.92	9.104	11.38	16
B5		E	Bulbs	0.576	1.066	1.33
B6	COMPUTER LAB	Fans	1.3365	2.473	3.09	6

Table 3.20 SIZE OF CIRCUIT BREAKERS IN DISTRIBUTION BOARD F3						
BREAKER	LOCATION	CONNECTED LOAD	CONSUMPTION (kW)	CURRENT (A)	CURRENT × 1.25	BREAKER SIZE (A)
B1	DO2		6.822	12.62	15.78	16
B2	MECHANICAL DEPARTMENT OFFICES		11.748	21.74	27.18	32
B3	SECURITY WING		2.685	4.97	6.21	10

Table 3.21 SIZE OF CIRCUIT BREAKERS IN DISTRIBUTION BOARD F4						
BREAKER	LOCATION	CONNECTED LOAD	CONSUMPTION (kW)	CURRENT (A)	CURRENT × 1.25	BREAKER SIZE (A)
B1	DO3		8.97	16.6	20.75	32
B2	DO4		4.662	8.63	10.79	16
B3	DEAN'S OFFICES		5.088	9.42	11.78	16
B4	LIBRARY WING		4.4145	8.17	10.21	16

Table 3.22 SIZE OF CIRCUIT BREAKERS IN DISTRIBUTION BOARD F5						
BREAKER	LOCATION	CONNECTED LOAD	CONSUMPTION (kW)	CURRENT (A)	CURRENT × 1.25	BREAKER SIZE (A)
B1	LT1		6.276	11.6	14.5	16
B2	LT2		3.726	6.89	8.61	10
B3	LT3		3.366	6.22	7.78	10
B4	LT4		3.51	6.5	8.13	10

B5	FACULTY BOARD ROOM		3.335	6.17	7.71	10
B6	NEW 1000LT BUILDING		25.442	47.08	58.85	60

Haven gone through the system design in this chapter, we proceed to explain the process involved in installing the solar system to power the Deans' Office, LT1, LT2, LT3, LT4, and the faculty boardroom.

CHAPTER FOUR

RESULT ANALYSIS AND DISCUSSION

4.1 COMPONENT SELECTION AND SPECIFICATION

The main components selected for the 10KW solar system include:

1. Lithium-ion battery

Although they are more expensive in terms of cost, lithium ion batteries hold an advantage over other kinds of batteries because they have fast response to charge and discharge operations and have a very high efficiency of almost 100%.

Table 4.1 Specification and Description of Battery Used

SPECIFICATION	DESCRIPTION
Model	PFLB15000
Energy capacity	48V / 300Ah /15KWh
Operating voltage	43.2 – 58.4V



Figure 4.1 Batteries Used

2. SRNE Hybrid Inverter

A hybrid inverter is preferred because of its ability to combine solar power and battery charger capacities all in one device, high energy conversion efficiency and it's overall cost effectiveness.

Table 4.2 Specification and Description of Inverter Used

SPECIFICATION	DESCRIPTION
Model	ASP48100S200-H
AC output power	10KW
Battery input	48Vdc (40V-60V)
PV charge to battery current	200Adc



Figure 4.2 Inverter Used

3. Change over switch
4. **Protection:** Breakers, Surge protective device, Adjustable current and voltage relay
5. **Monitoring system:** Wi-Fi

TOOLS USED:

1. Insulated screw driver and spanner
2. Insulated plier
3. Digital multimeter
4. Hammer
5. Adhesive duct Tape
6. 70mm² and 35mm² DC cables
7. Personal protective equipment

4.2 WIRING AND CONNECTION DIAGRAM

The schematic of the solar system is shown below:

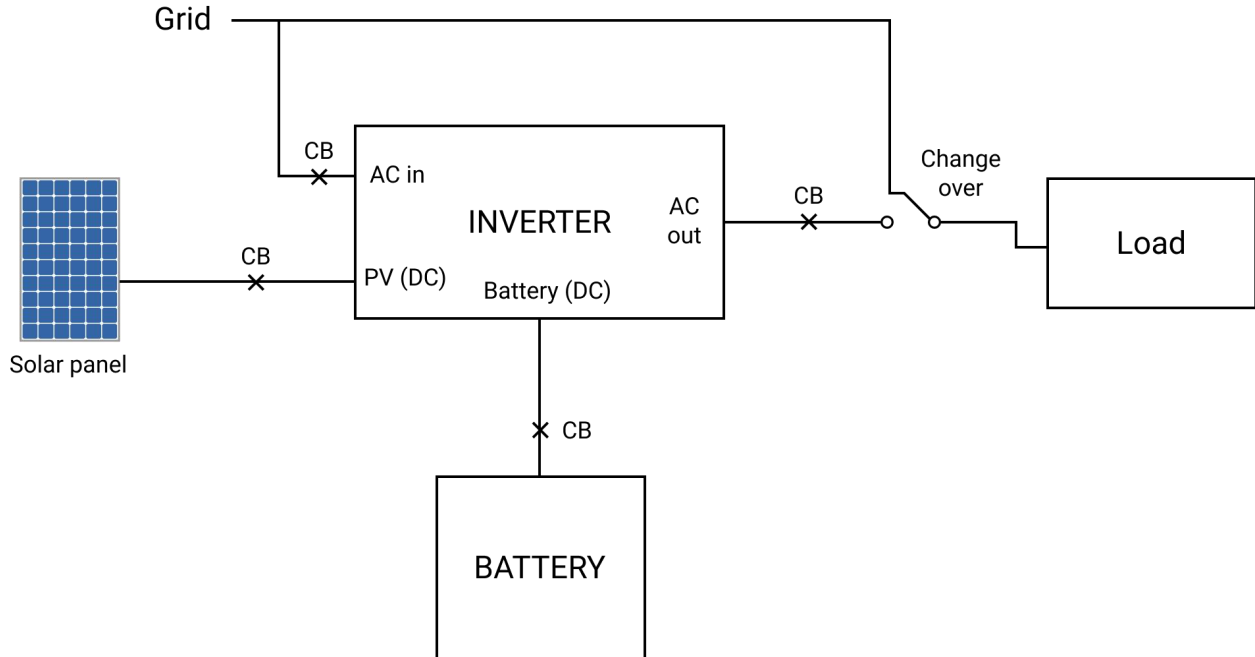

Figure 4.3 Wiring and Connection Diagram

4.3 INSTALLATION PROCESS

4.3.1 Clearing of the installation area

Before installation began, the designated installation area was cleaned. This was done to ensure safe working environment and to ensure proper ventilation in the working area. Dust and debris were removed from the installation area to ensure smooth working of the battery and inverter.

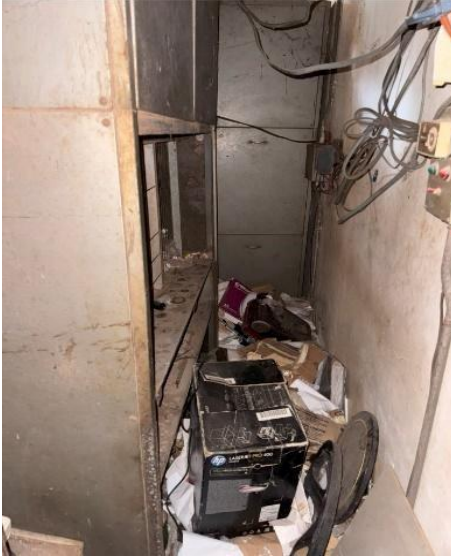

Figure 4.4 Clearing of Installation Area

4.3.2 Unboxing and inspection of batteries:

Each battery was carefully taken out of the box and carefully inspected.

- Visual inspection: Each battery was checked for physical damage or swelling.
- Terminal check: Verified terminal polarity and installation materials
- Voltage verification: A multimeter was used to check the factory voltage of both batteries. They fell within the range of 48 – 51.2V.
- Mounting: The batteries were moved and placed at the dedicated installation position.



Figure 4.5 Unboxing and Inspection of Batteries

4.3.3 Unboxing and inspection of inverter:

The 10 kW inverter was also carefully unboxed and we confirmed that the specifications matched the design.

The inverter was carefully mounted on a vertical wall with screws to hold it firmly in position.

4.3.4 Mounting of change over switch and protective devices

To ensure proper organization and protection of the system control and safety components, a plastic protective box was used. This box was properly mounted on the wall near the inverter to house the relays, surge protective device and circuit breakers. After securely mounting the box, the **adjustable voltage and current relays, breakers** and Surge protective device were carefully arranged inside the box.

The change over switch was also mounted on the wall after the protective device with enough spacing from the protective device and close to the DB (distribution board).



Figure 4.6 Protective devices

4.3.5 Connection and wiring

1) DB AND CHANGE OVER CONNECTION: The change over switch was mounted close to the existing distribution board for easy access and minimal cable length. After mounting, the **electrical connections were made** to allow integration between the inverter (solar output), the grid supply, and the load circuits. During the connection process:

- Separating load from the DB: The load was isolated from the DB and wired to pass through the change over switch.
- The inverter output was connected to one side of the change over switch.
- The grid supply was connected to the other side of the change over switch.

This arrangement allows for manual selection of power source (solar or grid) supplying the load depending on battery status or power availability.

2) BATTERY AND INVERTER CONNECTION: The two batteries were connected in

parallel through a circuit breaker with a 35mm² cable. This was done in order to maintain the system voltage (48V) while doubling the amp-hour capacity. The positive terminal of Battery 1 was connected to the positive terminal of Battery 2. The negative

terminal of Battery 1 was connected to the negative terminal of Battery 2. This was then connected to the positive and negative terminal of the circuit breaker.

Total capacity achieved:

Voltage: 48V (constant)

Storage: 15KWh * 2 = 30KWh total energy

A 70mm² **positive cable** was connected from the circuit breaker to the inverter's **positive DC input**, and the same for the negative. All connections were tightened properly. A **continuity and voltage test** was performed to ensure everything was properly connected before powering up the inverter.

- 3) **INVERTER AND OUTPUT CONNECTION:** From the grid terminal, a **wire was tapped** and connected to the **protective device box** mounted on the wall. Inside the box, the wire was routed through an **AC breaker**, an **adjustable AC relay**, and then connected to the **AC input of the inverter**. This setup allows the inverter to receive grid power for charging the batteries and assisting in load supply. The grid power was measured using a multimeter to be 230V.

The AC output of the inverter was routed through the protective devices and was then connected to the other side of the change over.

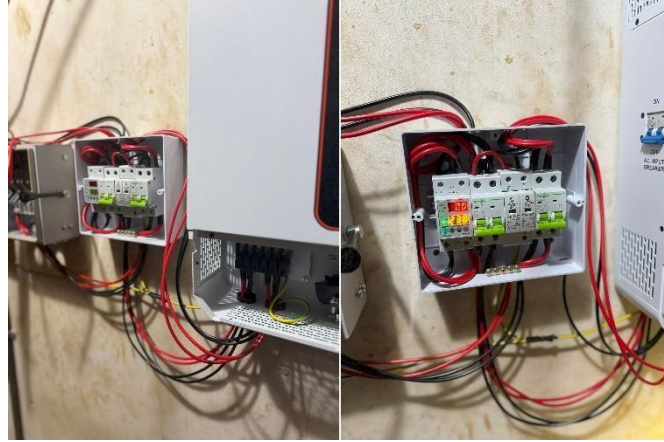

Figure 4.7 Inverter and Output Connection

4.4 SAFETY CONSIDERATIONS

Safety is an important aspect in electrical installation. We placed strong emphasis on safety to ensure both the protection of the system components and the people who will interact with it for maintenance in the future. The following considerations were implemented during the installation:

1) Component Isolation and Protection

- Protective devices like Adjustable current and voltage relay, circuit breaker were installed on both AC and DC sides to allow for complete isolation during maintenance or emergency situations. The adjustable voltage and current relays were used to monitor and automatically disconnect power in the event of abnormal voltage or frequency from the grid or inverter.
- A circuit breaker was placed in between the battery and the inverter to also protect the battery.

2) Earthing and Surge Protection

The earthing system helps prevent electrical shock in the event of insulation failure and provides a path for **surge discharge** during lightning events or grid faults.

3) Secure Mounting and Environmental Safety

The battery room was cleaned to avoid dust accumulation which can increase risk of short circuit. All equipments were securely mounted on the wall.

4) Complete Insulation

The adhesive duct tape was properly used to insulate exposed joints. This was done to prevent short circuit.

5) Correct Cable Sizing and Routing

All cables were sized based on load current, distance, and voltage rating.

6) Testing and Verification

- All wiring connections were checked to ensure tightness and continuity using a digital multimeter.
- The voltage level was measured at each level. A 233V was measured at the output level and 230V at the input level.
- **Polarity checks** were conducted on DC terminals to prevent damage.



Figure 4.8 Connection of Protective Devices

4.5 Maintenance Considerations

While installing the solar power system, several decisions were made with future maintenance, repairs, and possible system upgrades in mind. These considerations ensure that the system remains serviceable, safe, and adaptable over its lifespan.

First, the layout of components was arranged to allow easy physical access to the panels, charge controller, inverter, and batteries. This means that future technicians can reach and work on each part without dismantling other sections unnecessarily. The wiring was routed neatly through accessible conduits and trunking, avoiding sharp bends or hidden runs that would make fault tracing difficult.

Extra cable length was allowed where possible, especially in panel and battery connections. This means that if a wire needs replacing, re-terminating, or repositioning, there will be enough slack to work with without having to install new lengths entirely. Similarly, cable sizes were chosen with a slight capacity margin to handle small increases in load if extra panels or batteries are added in the future.

Clear labelling was applied to all cables, fuses, and breakers to make identification straightforward. This reduces the time spent diagnosing faults or making changes later. In addition, the protective devices (such as circuit breakers and surge protectors) were installed in a way that makes them easy to isolate and replace without shutting down the entire system unnecessarily.

Finally, the mounting structures were chosen with upgrade potential in mind. The panel frames can accommodate extra modules if needed, and the battery enclosure has space for additional units. All installation records, including wiring diagrams and component specifications, were documented and stored for future reference.

By taking these steps, the solar system is not only functional today but is also prepared for safe, efficient maintenance and future expansion.

4.6 BILL OF ENGINEERING AND MEASUREMENT EVALUATION FOR THE 10kW SYSTEM (DATE: 24TH OCTOBER, 2025)

TABLE 4.3 BILL FOR THE 10kW SYSTEM			
ITEM	PRICE PER UNIT (₺)	QUANATIT Y	COST (₺)
10 kW SRNE Hybrid Inverter	1,820,000	1	1,820,000
15 kWh Lithium Ion Battery	2,400,000	2	4,800,000
600 W Panels	115,000	36	4,140,000
Ac Breaker	10,000	1	10,000
Dc Breaker	10,000	1	10,000
Enclosure Box	8,000	1	8,000
10 mm ² Cable	6,500/m	200	1,300,000
1.5 mm ² Cable	1,000/m	50	50,000
Aluminium Rails	15,000	4	60,000
Bolts and Nuts	400	64	25,600
TOTAL			12,448,600

TABLE 4.4 BILL FOR 300 kW SYSTEM			
ITEM	PRICE PER UNIT (₺)	QUANTITY	COST (₺)
312 kW 480V Solar Hybrid Inverter	35,650,000	1	35,650,000
800 W solar panel	150,000	890	133,500,000
100 kWh LiFePO4 battery	32,900,000	18	592,200,000

Aluminium Rails	15,000	200	3,000,000
Bolts and Nuts	800	1,400	1,120,000
1.5mm cable	1,000/m	30m	30,000
2.5mm cable	1,600/m	15m	24,000
6mm cable	3,500/m	125m	437,500
10mm cable	6,500/m	210m	1,365,000
16mm cable	8,500/m	130m	1,105,000
25mm cable	14,500/m	25m	362,500
35mm cable	20,000/m	315m	6,300,000
50mm cable	31,000/m	150m	4,650,000
70mm cable	43,000/m	100m	4,300,000
120mm cable	72,000/m	488m	35,136,000
185mm cable	104,500/m	100m	10,450,000
240mm cable	135,000/m	25m	3,375,000
300mm cable	175,000/m	150m	26,250,000
TOTAL			859,255,000

CHAPTER FIVE

CONCLUSION

The successful completion of this project is indicative of progress made towards advancement of sustainable energy solution within the university environment. The development and installation of this standalone photovoltaic system for the faculty of engineering demonstrates the possibility and economic viability of transitioning from conventional power supply like the National Grid system to renewable power supply especially in a country like Nigeria where there is high solar power potential and increasing energy demand.

By carrying out data collection, load analysis and system design; we were able to propose a solution that fits the faculty's power needs while reducing reliance on the National grid. The implementation of this project does not only help to reduce power outage and reduce cost of power supply, but also promotes supply of reliable power and contributes to the University's commitment to environmental sustainability.

Despite the numerous challenges encountered while undertaking this project – including restricted access to some facilities, unavailability of staff, time constraint amongst others – careful planning, alternative data sources and engaging certain key personnel helped to resolve these issues to a large extent.

In conclusion, this project has provided us with practical and hands-on experience in implementing solar energy solution within the academic environment. It serves as a good contribution towards the integration of solar energy into the power supply system in institutions of higher learning and similar settings. Further research and collaboration with industry professionals can enhance the efficiency, scalability and integration of such systems, ultimately supporting a broader transition to clean energy across the educational sector and beyond.

5.1 RECOMMENDATION FOR FUTURE WORK

With maximum, the outcomes and limitations of this project give a heads-up on critical factors to be considered in future research and areas where developmental efforts should be strengthened in order to improve power security in the faculty of engineering. In light of the above, we recommend that future researchers consider:

1. Smart monitoring and automation: Future projects should incorporate the use of smart systems and IoT –based devices to improve the operation and performance of the system, detect faults and schedule maintenance.
2. Safety and economic impact assessment: Future projects should include assessment of the environmental impact to evaluate long-term benefits and socio-economic effects of solar energy adoption within the faculty.
3. Hybrid system integration: Subsequent works should consider exploring other renewable energy options such as wind or small-scale hydro systems and integrate them into the solar setup to create a hybrid system thereby enhancing stability and reliability of power supply in the faculty especially during prolonged periods of low solar irradiance.
4. Financing models: Future projects should consider the possibility of securing government subsidies, public/private partnerships and other financing models to fund large-scale solar projects of this nature, ensuring long-term finance viability.
5. Load expansion feasibility: Detailed feasibility study should be carried out to determine the scalability of the current system to power additional facilities or departments within the faculty based on future energy demands.

Addressing the above stated areas will enable future researchers to enhance the efficiency and reliability of solar energy systems for institutional use thereby promoting sustainable energy within the academic environment

REFERENCES

- Akinyele, D., Belikov, J., and Levron, Y. (2017). Battery storage technologies for electrical applications: Impact in stand-alone photovoltaic systems. *Energies*, 10 (11), Article 1760.
- AFSIA. (2025). *Nigeria adds 63.5 MWp solar capacity in 2024*. Africa Solar Industry Association Report.
- Ali, W., Sohail, S., and Hussain, S. (2018). Design considerations of stand-alone solar photovoltaic systems. *International Journal of Renewable Energy Research*, 8(2), 794–803.
- Ariyo, F.K., Famutimi, B.D., Olowu, T.O., Akintade, S.A., Abbas, A., 2016. Web-Based Application for the Sizing of a Photovoltaic (PV) Solar Power System. *American Journal of Engineering Research (AJER)* 219–222.
- Chen, H., Cong, T. N., Yang, W., Tan, C., Li, Y., and Ding, Y. (2009). Progress in electrical energy storage system: A critical review. *Progress in Natural Science*, 19(3), 291–312.
- Chineke, T. C., & Igwiro, E. C. (2008). *Urban and rural electrification: Enhancing the energy sector in Nigeria using photovoltaic technology*. *African Journal of Science and Technology*, 9(1), 102–108
- Dambhare, M. V., Bhole, S. M., and Dharmadhikari, S. P. (2021). Review of solar photovoltaic cell technologies. *Materials Today: Proceedings*, 46, 4353–4358.
- EVE Energy Co., Ltd. (2019, May 1). *LF90K 3.2 V 90 Ah LiFePO₄ battery cell – Product specification (Version A)* [Datasheet].
- Gul, M. S. (2016). Review on recent trend of solar photovoltaic technology. *SAGE*, 492.
- IEC 60947-2. (2016). Low-voltage switchgear and controlgear – Part 2: Circuit-breakers. International Electrotechnical Commission, Geneva.

IEC 60898-1. (2015). Circuit-breakers for overcurrent protection for household and similar installations – Part 1: Circuit-breakers for a.c. operation. International Electrotechnical Commission, Geneva.

IEC 60364-4-43. (2008). Low-voltage electrical installations – Part 4-43: Protection for safety – Protection against overcurrent. International Electrotechnical Commission, Geneva.

IEC 60364-4-41. (2005). Low-voltage electrical installations – Part 4-41: Protection for safety – Protection against electric shock. International Electrotechnical Commission, Geneva.

IEC 60364-5-52. (2009). Low-voltage electrical installations – Part 5-52: Selection and erection of electrical equipment – Wiring systems. International Electrotechnical Commission, Geneva.

IEC 60287-1-1. (2014). Electric cables – Calculation of the current rating – Part 1-1: Current rating equations (100% load factor) and calculation of losses. International Electrotechnical

IEC 62548. (2016). Photovoltaic (PV) arrays – Design requirements. International Electrotechnical Commission, Geneva.

IEC 60364-7-712. (2017). Low-voltage electrical installations – Part 7-712: Requirements for special installations or locations – Solar photovoltaic (PV) power supply systems. International Electrotechnical Commission, Geneva.

Majaw, T., Deka, R., Roy, S., and Goswami, B. (2018). Solar charge controllers using MPPT and PWM: A review. *ADBU Journal of Electrical and Electronics Engineering (AJEEE)*, 2(1), 1-4.

Mercury Direct. (2023). *Understanding solar peak sun hours: A comprehensive guide for Nigeria*. Mercury Direct Nigeria. Retrieved October 24, 2025, from <https://mercurydirect.com.ng/understanding-solar-peak-sun-hours-a-comprehensive-guide-for-nigeria/>

Mohanty, P., and Muneer, T. (2014). *Smart design of stand-alone solar PV system for off-grid electrification projects*. Springer.

Mughal, N., Bano, S., and Kazmi, R. (2018). A review of photovoltaic technologies. *International Journal of Renewable Energy Research*, 8(4), 2231–2239.

Oji, J., Idowu, O. A., and Kareem, B. (2012). Utilization of solar energy for power generation in Nigeria. *International Journal of Energy Engineering*, 2(2), 54–59.

Omubo-Pepple, V. B., Israel-Cookey, C., and Alaminokuma, G. I. (2009). Effects of temperature, solar flux and relative humidity on the efficient conversion of solar energy to electricity. *European Journal of Scientific Research*, 35(2), 173–180.

Optimised Power Products. (n.d.). *Nigeria: Power Factor Correction by Optimised Power Products*. Retrieved October 24, 2025, from <https://optimisedpowerproducts.com/nigeria/>

Oyedokun, T. (2024, December 15). *What frequent collapse of national grid means for Nigeria's development*. Business Day Nigeria.

Oyedepo, S. O. (2012). Energy and sustainable development in Nigeria: The way forward. *Energy, Sustainability and Society*, 2(1), 15.

Rastler, D. M. (2010). *Electricity energy storage technology options: A white paper primer on applications, costs and benefits*. Electric Power Research Institute (EPRI).

Rezvani, M., Gholami, A., Gavagsaz-Ghoachani, R., Phattanasak, M., and Zandi, M. (2022). A review of the factors affecting the utilization of solar photovoltaic panels. *2022 Research, Invention, and Innovation Congress (RI2C)*. IEEE.

Swarnakar, B., and Datta, A. (2016). Design and implementation of PWM charge controller and solar tracking system. *International Journal of Renewable Energy Research*, 5(5), 1214-1217.

Uyigüe, E., and Agbo, F. (2007). *Promoting renewable energy and energy efficiency in Nigeria*. Community Research and Development Centre (CREDC).

Voltmatic Energy Solutions. (2024, August 8). How to calculate the size of an inverter for your solar power system [Blog post]. Voltmatic Energy Solutions.

<https://voltmaticenergysolutions.co.ke/how-to-calculate-the-size-of-an-inverter-for-your-solar-power-system/>

Xu, L., Liang, L., and Li, H. (2020). Effect of dust accumulation on the efficiency of solar PV panels. *Sustainable Energy Technologies and Assessments*, 38, 100690.

Zhao, J., Wang, A., and Green, M. A. (1998). 19.8% efficient honeycomb textured multicrystalline and 24.4% monocrystalline silicon solar cells. *Applied Physics Letters*, 73(14), 1991–1993.