



**DESIGN OF AN INTERNET OF THINGS (IOT)BASED SMART HOME
AUTOMATION SYSTEM**

BY

ALBERT, EROMONSELE GODWIN

ENG1604118

OSAGIEDE, OSAHON OSAGIE

ENG1604196

OSAGIE, JAPHET ELOGHOSA

ENG1608011

OZIEGBE, EHIMEN RAPHEAL

ENG1604201

ODAFE, OMOGEKOMA PRINCE

ENG1604170

**DEPARTMENT OF ELECTRICAL/ELECTRONIC ENGINEERING
FACULTY OF ENGINEERING
UNIVERSITY OF BENIN, BENIN CITY**

DECEMBER, 2022



**DESIGN OF AN INTERNET OF THINGS (IOT)BASED SMART HOME
AUTOMATION SYSTEM**

BY

ALBERT, EROMONSELE GODWIN	ENG1604118
OSAGIEDE, OSAHON OSAGIE	ENG1604196
OSAGIE, JAPHET ELOGHOSA	ENG1608011
OZIEGBE, EHIMEN RAPHEAL	ENG1604201
ODAFE, OMOGEKOMA PRINCE	ENG1604170

**BEING A PROJECT SUBMITTED IN PARTIAL FULFILLMENT OF THE
REQUIREMENT FOR THE AWARD OF ENGINEERING (B.ENG) IN THE
DEPARTMENT OF ELECTRICAL AND ELECTRONICS ENGINEERING,
FACULTY OF ENGINEERING, UNIVERSITY OF BENIN, BENIN CITY.**

DECEMBER, 2022

CERTIFICATION

This is to certify that this project work titled “DESIGN OF AN INTERNET OF THINGS(IOT) BASED SMART HOME AUTOMATION SYSTEM)”, was carried out by ALBERT

EROMOSELE GODWIN (ENG1604118), OSAGIEDE OSAHON OSAGIE (ENG1604196), OSAGIE JAPHET ELOGHOSA (ENG1608011), OZIEGBE EHIMEN RAPHEAL (ENG1604201) and ODAFE OMOGEKOMA PRINCE (ENG1604170) in the Department of Electrical/Electronic Engineering, University of Benin, Benin City, Edo State, Nigeria.

.....

Engr. E. Osa

Supervisor

.....

Date

.....

Prof. (Mrs.) P. E. Orukpe

Head of Department (HOD)

.....

Date

DEDICATION

This work is dedicated to Almighty God for his guidance and protection all through this research work and seeing the completion a successful one. This project is also dedicated to our parents and guardians who gave us the opportunity and encouragement to grow and reach the end of an important phase in our lives.

ACKNOWLEDGEMENT

We would like to acknowledge Almighty God who gave us the guidance to choose Electrical/Electronic as a course of study and also see us through right to the very end of this bachelor's degree.

We would like to say that there are so many people to thank, however, we will like to thank the Electrical/Electronic Engineering department, University of Benin, for providing the platform on which we were engaged with this project.

We want to say a big thank you to our project supervisor, Engr. E. Osa for his constant support, patience and guidance. A big thank you to the Head of Department (Electrical/Electronic Engineering) Prof. (Mrs.) Patience E. Orukpe.

We are grateful to all staff and students of the department of Electrical/Electronic Engineering for making our period in University of Benin a time worthwhile and a successful one.

We want to thank our families for the encouragement and financial support throughout our time spent in the University of Benin, they encouraged us all through our years of learning and also appreciate our siblings for their care and vital support.

We are highly grateful.

TABLE OF CONTENTS

CERTIFICATION	ii
DEDICATION	iii
ACKNOWLEDGEMENT	iv
ABSTRACT	ix
LIST OF FIGURES	x
LIST OF TABLES	xi
LIST OF EQUATIONS	xii
ABBREVIATIONS	xiii
CHAPTER ONE	14
INTRODUCTION	14
1.1 BACKGROUND OF STUDY	14
1.1.2 Why Automation?	4
1. Home Automation	5
2. Building Automation	5
3. Office Automation	6
4. Power Automation	6
1.2 PROBLEM STATEMENT	6
1.3 AIM	6
1.4 OBJECTIVES	6
1.5 METHODOLOGY	7
1.6 SCOPE OF STUDY	7
1.7 PROJECT JUSTIFICATION	8
CHAPTER TWO	9
LITERATURE REVIEW	9
2.1 INTRODUCTION	9
2.2 HISTORY OF HOME AUTOMATION	11

2.3	RELATED WORKS	13
2.3.1	Home Automation System using Google assistance (B.tech student, Department of computer science and Engineering, presidency University, Bangalore)(Chenumalla, 2019).	13
2.3.2	Remotely controlled home automation system (Dept. of CSE, MNNIT Allahabad) (Dahwan, 2015).....	13
2.4	CATEGORIES OF HOME AUTOMATION SYSTEM	14
1.	Powerline carrier systems	14
2.	Wireless systems	14
3.	Hardwired systems	15
4.	Internet Protocol control system	15
2.5	HOME AUTOMATION IMPLEMENTATION PLATFORMS	15
2.5.1	Powerline communication	15
2.5.2	RS232	16
2.5.3	Ethernet	17
2.5.4	Bluetooth	18
2.5.5	Infrared	19
2.5.6	GSM	19
2.5.7	Microcontroller	20
2.5.7.1	Von-Neuman Architecture	21
2.5.7.2	Harvard Architecture	21
2.6	CONCEPT AND PRINCIPLE OF IOT BASED AUTOMATION SYSTEM.....	22
2.7	COMPONENT USED	22
2.7.1	TRANSFORMER	22
2.7.2	RECTIFIER	24
2.7.3	FILTER CAPACITOR	25
2.7.4	REGULATOR	25
2.7.4.1	DC-DC CONVERTER	25
2.7.5	MICRO CONTROLLER	26

2.7.5.1 IMPORTANT FEATURES OF ESP32-WROOM.....	26
2.7.5.2 REASONS FOR SELECTING ESP32-ROOM FOR THIS PROJECT	27
2.7.5.3 POWER REQUIREMENT	27
2.7.5.4 ESP32 PINS	28
2.7.6 RELAYS	28
2.7.6.1 OPERATING PRINCIPLES OF THE RELAY	28
2.7.7 TRANSISTORS	29
2.7.8 DIODES	29
CHAPTER 3	30
METHODOLOGY	30
3.1 INTRODUCTION	30
3.1.1 SYSTEM DESIGN AND OPERATION (BLOCK DIAGRAM)	30
3.2 POWER SUPPLY UNIT	31
3.2.1 FILTER CAPACITOR	31
3.2.2 TRANSISTORS	32
3.3 SOFTWARE APPLICATION	32
3.4 SETTING UP THE SYSTEM	33
3.5 HARDWARE ASSEMBLING AND PRINCIPLE OF OPERATION	35
3.6 CIRCUIT DIAGRAM	36
36	
CHAPTER 4	37
CONSTRUCTION, TESTING & RESULT	37
4.1. CONSTRUCTION	37
4.2. TOOLS USED	37
4.2.1. Soldering Iron and Soldering Lead	38
4.2.2. Vero-board	38
4.3. TESTING	38

4.3.1. PRE-IMPLEMENTATION TESTING	38
4.3.1.1. MOUNTING AND CONNECTION OF COMPONENTS	39
4.3.2. POST-IMPLEMENTING TESTING	40
4.4. TESTING OF PROTOTYPE	41
4.4.1 TESTING OUTLINE	43
4.5. COUPLING	45
4.6. PROBLEM ENCOUNTERED	45
4.7. PRECAUTION	45
4.8. BILL OF ENGINEERING MEASUREMENT AND EVALUATION OF QUANTITIES	46
CHAPTER 5	47
CONCLUSION AND RECOMMENDATION	47
5.1. CONCLUSION	47
5.2. LIMITATION	48
5.3. RECOMMENDATION AND FUTURE WORKS	48
REFERENCES	49
APPENDIX	50
PIN LAYOUT	50
CODE	53

ABSTRACT

The Internet of Things (IoT) describes a kind of network which interconnects various devices with the help of internet. IoT assists to transmit data with among devices, tracing and monitoring devices and other things. IoT make objects 'smart' by allowing them to transmit data and automating of tasks, without human interference. A health tracking wearable device is an example of simple effortless IoT in our life. A smart city with sensors covering all its regions using diverse tangible gadgets and objects connected with the help of internet is another example.

However, there are still a lot of challenges and issues that need to be addressed to achieve the full potential of IoT. These challenges and issues must be considered from various aspects of IoT such as applications, challenges, enabling technologies, social and environmental impacts etc. This project presents a simple method for developing Wi-Fi and Bluetooth Home Automation System that monitors the electrical energy consumption of our houses with real-time tracking. A custom node microcontroller unit (ESP) serves as the main control unit. It is interfaced with sensors that give the real-time status of the surroundings and also monitor various appliances like lights, fans, etc. Light bulbs and sockets are used to represent the house hold appliances. Communication between human and electrical devices is orchestrated via an android application namely Blynk. Test results of the designed system show that the electrical appliances can be turned On and Off by the Smart arrangement.

LIST OF FIGURES

Fig. 1.1 – Applications of Home Automation System.....	2
Fig. 2.1 – Top Consumers List For Most Desired Smart Home Devices.....	9
Fig. 2.2 –History Of Home Automation	11
Fig. 2.3 –Bluetooth Based Home Automation	17
Fig. 2.4 – Mobile Based Home Automation.....	19
Fig. 2.5–12V /1.5A Transformer.....	22
Fig. 2.6 – Rectifier.....	23
Fig. 2.7– Filter Capacitor.....	24
Fig. 2.8 – Dc-Dc Converter	24
Fig. 2.9 – Esp32-wroom.....	25
Fig. 2.10 – Relays.....	27
Fig. 2.11 – Transistors.....	28
Fig. 2.12 – Diode.....	28
Fig. 3.1– Block Diagram Of The Smart Home Automation System.....	29
Fig 3.2 – Power Supply Unit.....	30
Fig 3.3 –Blynk Application Interface.....	33

LIST OF TABLES

Table 3.1 – Configuration Of The Blynk Mobile App.....	32
Table 4.1 –Result Of Voltage Regulator Test.....	38
Table 4.2 – Device 1,2,3 (13A Socket).....	40
Table 4.3 – Device 3,4,5 (Lamp Holder With Load).....	41
Table 4.4 –Displaying Outage For Daily Supply.....	42
Table 4.5 – Reliability Table For Power Outage.....	43
Table 4.6- List of component Used.....	45

LIST OF EQUATIONS

Equation 2.1–Secondary Voltage To The Primary Turn Of The Transformer.....	22
Equation 2.2 – Primary Voltage To Secondary Turn Of The Transformer	23
Equation 2.3 – Equation For The Voltage To Turn Ratio Of The Transformer.....	23
Equation 3.1–Equation For The Capacitance Of The Capacitor.....	30
Equation 3.2 – Equation For the Resistance Of The Transistor.....	31

ABBREVIATIONS

BAS – Building Automation System
HASs – Home automation Systems
IoT – Internet of Things
IP – Internet Protocol
MCU – Microcontroller Units
IC – Integrated Circuit
LED – Light Emitting Diode
IDE – Integrated Development Environment
RID – Radio Frequency Identification.
CPU – Central Processing Unit
SCADA – Supervisory Control And Data Acquisition
USB – Universal Serial Bus
WIFI— Wireless Fidelity
GND – Ground
LAN –Local Area Network
AC – Alternating current
DC – Direct Current
DTE – Data Terminal Equipment
DCE – Data Communication Equipment
PAN – Personal Area Network
GFSK – Gaussian Frequency Shift Keying
GMSK – Gaussian Minimum-Shift Keying
GPS – Global positioning System
ISM – Industrial Specific And Medical
SIG – Special Interest Group
IR – Infrared
LE – Low Energy
LV – Low Voltage
HV – High Voltage

EN – Enable pins

RMS – Root Mean Square

PCB – Printed Circuit Board

GSM – Global System For Mobile Communcation

IFTTT – If This Then That

CCTV – Close Circuit Television

TV – Television

IN -In-out pins

L – Length

R – Resistance

C – Capacitance

VCC – Voltage Common Collector

NC – Normally Closed

NO – Normally Open

GPIO – General Purpose Input/Output

CHAPTER ONE

INTRODUCTION

1.1 BACKGROUND OF STUDY

Digitization has altered the entire planet in the 21st century. Smartphones are utilized by people from diverse backgrounds. A few years ago, there was a huge shift in the way that phones were produced, and today, they are utilized for a variety of purposes besides making phone calls. In a similar fashion, dwellings have evolved from ordinary to intelligent. Because of the development of IoT, this change became possible. As a result of the rapid expansion of the Internet of Things, smart homes are able to incorporate a variety of sensors, appliances, and robotics. As a result, several applications and use cases have been created for the human race. Recent integration of cloud services with home automation systems has enabled real-time status updates and monitoring. It has opened up new opportunities for controlling things from anywhere in the world. Furthermore, we may witness a dramatic increase in demand for home automation systems for a variety of reasons. It provides protection for the homes, aids disabled individuals, and most significantly, integration of these systems is economical.

Imagine how convenient it will be to turn on your air conditioning system ten minutes before you go home on a hot January afternoon. How about having a security system that detects and alerts you to smoking, excessive electrical power usage, attempted break-ins, and unauthorized movement in your home? This is what home automation is all about, and its applications are limitless. In reality, sophisticated home automation systems are currently being developed that can manage an inventory of household objects, monitor their usage via RFID (Radio Frequency Identification) tags, generate a shopping list or automatically order replacements, and produce a shopping list. The smart home currently offers the following features: a smart refrigerator, smart washing machine, smart television, smart coffee maker, smart apparel, etc. Typically, smart houses include an alert system. It is a vital component of a home automation system because it provides security not just for the home but also for the appliances. It provides monitoring and control for numerous home appliances. For instance, we can use an app to control the lights/fans in a certain room of the house. It also contributes intelligence. For instance, we can define a threshold for a temperature sensor, and when that threshold is exceeded, the fans in that room can automatically turn ON/OFF. As jobs can be automated, intelligence also contributes to energy savings.

Home automation has made it possible to have what is commonly referred to as a smart home', a home that can detect and identify you, automatically adjust the lighting to your predefined taste, open doors automatically, play your favorite music, water your flowers in the morning,

turn on the security lights at night and turn them off in the morning, heat water for bathe and tea, and stream to you anywhere in the world via the internet a live video of what is happening in an area of your house. It makes it feasible to integrate lighting, entertainment, security, telecommunications, heating, and air conditioning into a centralized system. This allows you to make your home an active participant in the management of your hectic life. Today, it is difficult to find a home without a home automation system, which can range from a remote control for the television to an automated air conditioning system that maintains a predetermined temperature.



Fig. 1.1 – Applications of Home Automation System) (Maksuki, 2021)

The ease with which we can turn on or off our appliances, lighting points, and sockets necessitated the development of a home automation system that allows us to remotely operate our appliances, lighting points, and plugs from a central location. The problem of forgetting to turn off appliances before going to bed or leaving the house has frequently resulted in fires and explosions in homes. The purpose of a home automation system is to provide assistance and support in order to meet some of the demands of the elderly and disabled in the house, as the elderly and disabled frequently have a desperate desire to regulate their home environment. There is also a need to regulate energy use in the home, as leaving the lights, fans, air conditioner, television, home theater system, and stereo on when they are not in use costs energy. In addition, leaving one's comfort zone to manually turn off unnecessary home appliances might be difficult after a long day or when one is simply too lazy to rise. Since ancient times, the concept of "Home Automation" has existed. The phrases "Intelligent Home" and "Smart Home" were coined to describe the concept of networking appliances and devices in the home. Home automation systems (HAS) give a tremendous opportunity for study in the development of new disciplines in engineering, computer, and architecture.

HASs are becoming increasingly prevalent and are swiftly penetrating this new market. In spite of this, end users, especially the disabled and old, do not generally accept these devices due to their complexity and expense. Home automation systems encounter a number of obstacles, including inflexibility, a high total cost of ownership, trouble attaining security, and poor management. Smart phones are becoming increasingly prominent as CPUs, entertainment features, storage capacities, and communication channels improve. Bluetooth, which is mostly used for data exchange, adds new characteristics to mobile phones. Ericsson, a Swedish telecommunications company, developed Bluetooth technology in 1994. Smartphone integration highlights Bluetooth's advantages. It has transformed how people use digital gadgets at home and in the workplace, replacing wired digital devices with wireless alternatives. This is a whole new innovation to domestic users and home owners as it allows to save energy and control lighting and electrical appliances even without being physically present at where these actions ought to have been taken. The use of Home Automation has considerably grown over the years as more ways to make the technology easier and better for the end users.

This is an entirely new idea for residential users and property owners, as it enables energy conservation and remote control of lighting and electrical equipment. The use of Home Automation has increased significantly over the years as additional methods have been developed to make the technology more user-friendly and beneficial.

1.1.2 Why Automation?

Automation is the utilization of control systems and information technology to control equipment, industrial machinery, and processes, thereby eliminating the need for human interaction. Automation is a step beyond mechanization in the context of industrialization. Mechanization supplied human operators with machines to aid them with the physical demands of their jobs, whereas automation significantly reduced the need for human sensory and cerebral demands (Wikipedia, 2009). Automation has an ever-increasing role in the global economy and in daily life. Engineers try to combine automated devices with mathematical and organizational tools to develop complex systems for an ever-expanding variety of human activities and applications. Currently, automation cannot replace a large number of human functions in industrial operations. Modern mechanical and computer systems are incapable of pattern recognition, language recognition, and language synthesis at a level comparable to that of humans. Currently, human experience is required for jobs

requiring subjective evaluation or synthesis of complex sensory data, such as odors and sounds, and for high-level tasks like strategic planning. Automation has had a significant effect on a vast array of highly visible industries outside of manufacturing. Telephone operators have been mainly supplanted by automated telephone switchboards and answering machines. Automated systems carry out medical procedures such as primary screening in electrocardiography or radiography and laboratory analysis of human genes, blood plasmas, cells, and tissues with a great deal more speed and precision. Teller machines have decreased the requirement for bank visits to acquire cash and conduct transactions. In general, automation was responsible for the transformation of the global economy from agricultural to industrial in the nineteenth century and from industrial to service-based in the twentieth century.

Depending on the area of usage, there are various types of intelligent automation systems, which we will briefly describe in the next section:

1. Home Automation

Home automation may refer to a growing practice of increased automation of domestic appliances and features in residential dwellings, especially through electronic means that enable things that were impractical, prohibitively expensive, or simply not conceivable in the preceding decades. In addition to climate controls, door and window controls, pet feeding, plant watering, and so on, home automation also covers the control of multimedia home theaters, animal feeding, and so forth. But there is a distinction in that home automation emphasizes comfort through ergonomics and ease of use more than commercial automation.

2. Building Automation

The functionality supplied by the control of a building is described by building automation. A computerized, intelligent network of electrical devices meant to monitor and regulate the mechanical and lighting systems of a building. An example of a distributed control system is a system for building automation. The building automation system's (BAS) fundamental operation maintains the building climate within a predetermined range, provides illumination based on an occupancy schedule, monitors system performance and device failures, and sends email and/or text alerts to building engineering staff. In comparison to uncontrolled buildings, the BAS feature decreases energy and maintenance expenses.

3. Office Automation

Office automation refers to the diverse computer hardware and software used to digitally create, gather, store, manipulate, and transmit office data required to complete fundamental tasks and objectives. Raw data storage, electronic transfer, and the administration of electronic business information are the fundamental functions of an office automation system. Office automation helps to optimize or automate existing office processes.

4. Power Automation

Power automation refers to the automated control and monitoring of power plants, substations, and transformers for efficacy, efficiency, and fault detection. It has made it feasible to have a dependable municipal or national electrical system, which frequently consists of remote and difficult-to-access transformers and power subsystem devices. It enables the monitoring of many power units, the transmission of their status and health information, and even the automatic detection and rectification of faults. SCADA (Supervisory Control and Data Acquisition) is an example of a power automation system.

1.2 PROBLEM STATEMENT

Millions of power consumers face a formidable hurdle when attempting to save energy at home. As a result of their personal responsibilities and manner of life, a large number of people are perpetually on the road.

This paper will examine how to reduce excessive electricity expenditure, improper control and monitoring of electrical devices and appliances resulting in overvoltage or device malfunction, and the inability to respond to emergency situations such as electrical faults due to the absence of the home owner.

1.3 AIM

This project attempts to develop and build a smart home automation system using Internet of Things technology (IOT).

1.4 OBJECTIVES

The project seeks to satisfy the following objectives:

- i. To design a home automation system using ESP32 WROOM microcontroller that saves electrical energy and cost of its users on running electrical appliances and devices.
- ii. To construct and implementing home automation system using available electronics and hardware.
- iii. To connect load appliances to the automated system.
- iv. To implement a communication channel between the controller and the automated system.
- v. To integrate a mobile application by which users can control and check the status of various appliances anywhere at any time.

1.5 METHODOLOGY

- i. The custom made IoT board is used to design the energy-efficient smart home automation system by utilizing an ESP32 microcontroller which has a WIFI module integrated along with it.
- ii. The automated system and associated electronics and hardware will be mounted on a wooden board.
- iii. Lamp holders with electric bulbs as well as other connections will be used to represent household appliances.
- iv. The smartphone, acting as wireless controller, will be connected wirelessly over the internet to the microcontroller to enable remote control of home appliances as well as communication on updated states of the appliances at any location.
- v. An application software, namely Blynk will be used to control and observe the status of the various loads.

1.6 SCOPE OF STUDY

This work is confined to the remote control and automation of just one residential apartment.

1.7 PROJECT JUSTIFICATION

This project will contribute expertise on how to construct smart home automation systems compatible with the Nigerian environment. This is due to the fact that the Nigerian power system is riddled with examples of overspending, faulty monitoring and regulation of electrical appliance usage, and faults such as overvoltage, spikes, etc. that cause emergency situations and other accidents.

CHAPTER TWO

LITERATURE REVIEW

2.1 INTRODUCTION

Home automation could refer to either the process of automating a home's systems or to the automating system itself, depending on the context. Increased convenience and high quality of life are two outcomes of installing home automation systems. Due to all the advantages it provides, home automation is a rapidly growing field of study. This is because we live in a time where the number of people using the internet and the number of programs it supports continues to rise. The term "home automation" describes the process of automating and, in some circumstances, remotely managing a home's many systems and appliances. We can find the roots of the modern home automation movement in the early 1970s. As time goes on, people expect to be able to remotely access, control, and monitor an increasing number of settings and parameters on any network-enabled appliance. This yearning has been on the rise. The goal of the international community is to automate as much of life as possible to make it simpler, safer, and less resource-intensive. Eventually, this system might be used to regulate the building's HVAC, lighting, machine operation, and even the locking of security doors.

More and more individuals are becoming aware of the need of greening their homes in today's world. The user of a smart house can better manage the amount of energy spent and realize more cost savings by regulating the lighting, window coverings, watering, and monitoring usage. Smartphone users are increasingly curious in the possibility of using their devices to manage their home electronics. This is because of the convenience and power of smartphones. With automatic appliance control, users can have things done before they even get home. The elderly and the physically impaired can greatly benefit from assistive technologies, and smart home control systems, which make use of mobile remote-control software, provide a solution. About 72% of respondents stated that self-adjusting thermostats were the most significant function, and 71% said that doors that can be shut from a distant place were the most important feature when considering the most wanted smart home gadgets. These numbers reflect the significance of these characteristics. Figure 2.1 illustrates the features of a smart house and the enthusiasm its users feel for the technology. Smart home research is on the rise, but not everyone can benefit from this technology just yet. The complexity and high cost of these systems make them less accessible to persons with

physical limitations or older adults. There is a fee associated with using the GSM network for communication, and that fee increases with each message sent. The proposed system should also have a straightforward GUI for controlling and monitoring the system's operations. With a webserver, you can reach consumers on all different kinds of mobile devices with just one website, making it the greatest option for dealing with this issue. When compared to native applications, which must have a variant designed for each device type, this is a significant advantage. The smart home control system proposed in this study has the potential to reduce the time and effort required to complete common household chores. Automated household appliances that respond to sensor reading and a user's manual push of a button can be included into a website interface to eliminate the need for human intervention and boost security. The control system's autonomous function, which relied on data gathered from sensors, allows it to perform its tasks in a timely and efficient manner. Access to the internet is required for the usage of IP networking apps and devices in the house, which allows users to operate their home appliances from almost anywhere using a laptop computer, mobile phone, tablet computer, or smart TV. The website's accessibility benefits everyone, but individuals with disabilities or age will find it especially helpful. This study provides a password-protected website as a solution to the security issue. In addition, a solar charger can be installed to restore power to the dead battery, fixing the underlying cause of the problem. This solar recharge controller may double as a backup supply in the event of a blackout. (Institute of Advanced Engineering and Science, 2017).

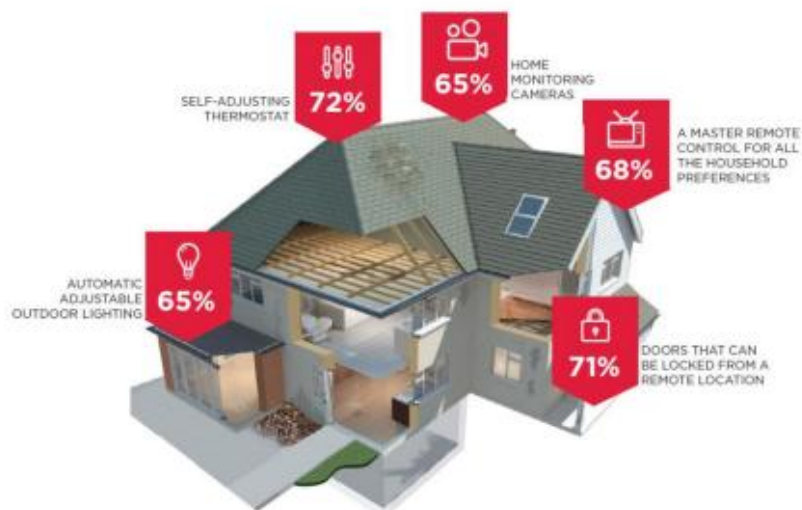

Fig. 2.1 – Top Consumers’ Lists for Most Desired Smart Home Devices(Singh, 2021)

2.2 HISTORY OF HOME AUTOMATION

People's lives today are significantly impacted by the fundamental automation systems in many ways. Motion sensing, intelligent thermostat control, adaptable luminescence, radio frequency identification, biometrics, infrared technology, radio frequency technology, CCTV security, and similar technologies have become very commonplace in recent years. There are already applications for highly developed automation technology, such as user recognition based on facial characteristics, voice-controlled commands, assistance with planning, and advice regarding activities of daily living. The number of people automating their homes is quickly becoming more common. According to ABI Research, there were 1.5 million home automation systems installed in the United States in 2012. If the market continues to grow at its current rate, shipments could reach over 8 million in 2017. John Chambers, the CEO of Cisco, believes that the market will be worth 19 trillion dollars by the year 2020 (Cheng, 2020). In the year 2014, Google spent \$3.2 billion (£2 billion) to acquire a company that was known as Nest Labs. Nest Labs, which is based in California, is a manufacturer of "smart" home appliances. After leaving his position as head of music at Apple in 2008, Tony Fadell, also known as the "godfather of the iPod," established the company that would later become known as Nest. Even though Nest has a large number of devices geared toward research, Nest Labs only has two products available on the market at this time: a smart smoke alarm and a smart thermostat. Nest intends to improve the intelligence of household appliances by incorporating into them a variety of one-of-a-kind features, such as a washing machine that will text its status and a refrigerator that can call. It is unknown how many features users desire in the home appliances they purchase for their homes. On the market right now, you can find a wide range of prices for home automation products, from very affordable to very pricey. Each possesses a method for communicating with the controllers of the devices. For instance, RF-based remotes can be used to turn lights on and off; smart plugs, which can be controlled by a mobile device such as a smartphone or tablet and which can then be used to control particular electronic devices; Since the 1970s, people have been able to use technology to detect motion. An excellent illustration of automation would be a door that opens automatically whenever someone walks in front of it. These are just a few examples of the many different kinds of intelligent systems that are out there. The most important thing is that they are intelligent.

History of Home Automation

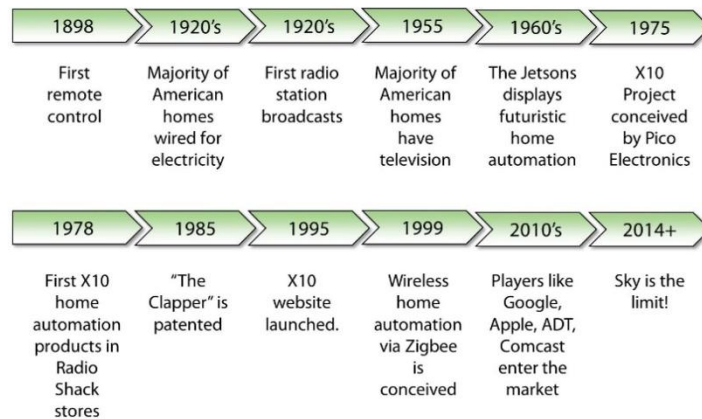

Fig. 2.2 – History of Home Automation (Dietrich, 2014)

Home automation has been around since before the first world war; in fact, the television remote, which is a basic form of home automation, was patented in the year 1893. (Wikipedia, 2009). Since then, a variety of home automation systems have developed, with the industry seeing a significant spike in growth after the Second World War. It has expanded thanks to a variety of unofficial studies and designs carried out by technology enthusiasts who are looking for a way to improve something they do at home with minimal effort on their part. In times past, communication was accomplished through laborious means, such as physically making the journey to the location of the other party, mailing letters, and so on. People are able to communicate with one another through a variety of channels such as e-mail, Facebook, GSM, and so on. Communication has been fundamentally transformed by the advent of the digital age; in today's world, the vast majority of people have access to mobile phones, and as a result, the world has truly become a global village. Mobile phones make it possible to get in touch with virtually anyone, anytime, anywhere, and about anything.

Many other projects involving home automation are currently being worked on in a variety of countries. Each one is distinct from the others in terms of its architecture, features, devices, elements, and algorithm. They were developed in response to particular requirements as well as the accessibility of components in the respective regions. Some of them are relatively inexpensive, while others can be quite costly. It is essential to have access to both hardware and software in order to function. After conducting extensive research, we were able to locate a large number of articles.

2.3 RELATED WORKS

2.3.1 Home Automation System using Google assistance (B.tech student, Department of computer science and Engineering, presidency University, Bangalore)(Chenumalla, 2019)

By using IoT, they were able to successfully control the appliances at different areas. The system was built to remotely control the home by using Node micro controller. This project was targeted towards the physically disabled or elderly persons through the use of voice control. The speech from the user will be given as the input to the microphone. The system cannot work if the speech recognition is poor. The microphone recognizes the speech given by the person and then sends it to the recognizing module which searches the IFTTT website. The system searches for the specific or related word even if there is any disturbance and when the command (OFF/ON) is given, the action is done. The result of this project was successful as the microcontroller was able to recognize command the google voice assistant application which was the voice recognition system in this case and sends these voice commands over the air through IoT to the microcontroller that processes the information and turned (ON/OFF) the appliances connected to the relays.

The micro controller used in this project is the Node MCU which has limited number of usable pins which reduces the number of appliances that can be added and controlled by this project whereas in our project the microcontroller used which is ESP32 has more usable pins and accommodates more connection of appliances.

2.3.2 Remotely controlled home automation system (Dept. of CSE, MNNIT Allahabad) (Dahwan, 2015)

This project presents an architecture that uses an android phone, a laptop computer, a microcontroller and a switching circuit. The android phone is used to run the designed application that controls the application. In this project, the laptop acts as a server communicating the commands to the microcontroller which in turn switches the relay that is connected to the appliances and the action is carried out to turn ON/OFF the appliances. The request to turn ON/OFF the device can also be given through the web interface. The microcontroller used in this project is the ATmega16 IC while the Wi-Fi module used is ESP8266. For this project the application on the android phone communicates with the laptop that acts as the server whereas in our project the mobile application communicates with the web server directly and the cloud server send the commands to the microcontroller

that sends instructions to the relay that turns ON/OFF the appliances. For this project there are lots of components required which include a laptop that acts as server, a microcontroller, a separate Wi-Fi module to communicate with the web server and having all these components can be expensive whereas in our project the ESP32 board has inbuilt microcontroller and Wi-Fi module and it is cheap to acquire.

2.3.3 Md Sarwar Kamal in (2017) Efficient Low-Cost Supervisory System for Internet of Things.

This paper proposed an efficient low-cost supervisory system for smart home automation that can be managed by IoT. The proposed system is based on Apriori algorithm and will help to monitor and control all the home appliances and electronic devices using the supervisory system. The environment is based on microcontroller (Arduino pro mini). WIFI module (ESP8266 Wi-Fi chip) some relays and an LCD. LCD notifies common parameters such as date, time, temperature and the device condition (ON/OFF). The result of this paper was actualized as they were able to control and monitor these devices and their rate and other physical quantities. However, there was considerable delay before the instructions are implemented due to the low processing ability of the microcontroller. Whereas for our project Esp32 which has a faster processor is used to achieve a faster delivery time of commands.

2.4 CATEGORIES OF HOME AUTOMATION SYSTEM

The following categories of home automation systems are classified according to their use of the carrier mode:

1. Powerline carrier systems

The type of home automation system that operates over the home's existing wiring, also known as the powerline carrier, is the one that costs the least. Lamp timers based on X10 are just one example of this category. More complex systems, which require installation by an experienced technician, are also included.

2. Wireless systems

There are also radio frequency technology-based wireless home automation systems available on the market today. They are typically employed for the purpose of operating lights, sometimes in conjunction with a system of lighting control that is hardwired.

3. Hardwired systems

Home control systems that are wired, also known as "hardwired," are the most expensive and reliable option. These systems are able to function over high-grade communications cable such as Category 5 or 5e, in addition to their very own "bus" cable that they have developed themselves. Because of this, it is advisable to prepare for them prior to the construction of a house. Because hardwired systems are capable of performing more tasks at once, as well as performing those tasks quickly and reliably, they are ideal for use in larger homes. They are also able to integrate additional systems within the home, effectively tying together a variety of systems such as the indoor and outdoor lighting, audio and video equipment, security system, and even the heating and cooling system into a single control package that is simple and straightforward to use.

4. Internet Protocol control system

A home automation system that is controlled by Internet Protocol (IP) utilizes the internet, assigns an Internet Protocol address to each device that is under its control, and establishes a local area network (LAN) in the residence. Therefore, it is possible to interact with the home over the internet, and there is also the possibility of live video streaming and control in real time.

2.5 HOME AUTOMATION IMPLEMENTATION PLATFORMS

Home automation can be implemented using a variety of different platforms, including Powerline, RS232 serial communication, Ethernet, Bluetooth, Infrared, and GSM. Infrared and Bluetooth are also viable options. Each platform has its own set of idiosyncrasies and areas in which it can be used (Soliman, 2017)

2.5.1 Powerline communication

The term "powerline communication" refers to a method of transmitting data over a conductor that is also used for the transmission of electrical power. In spite of the fact that electrical power is transmitted over high voltage transmission lines, distributed over medium voltage, and used inside buildings at lower voltages, powerline communication can be applied at each stage.

The imposition of a modulated carrier signal onto the wiring system is the fundamental mode of operation for all powerline communication systems. Different kinds of powerline

communications make use of various frequency bands, each of which is determined by the particulars of the signal transmission provided by the power wiring in question. As a result of the fact that the power wiring system was initially designed for the transmission of alternating current (AC) power, the power wire circuits have only a limited capacity for carrying higher frequencies when they are used in conventional applications. The issue of propagation is a factor that restricts the use of each and every type of powerline communication. There is a wide range of possible data rates when using a powerline communications system. Low-frequency carriers, which range from about 100 to 200 kHz, can be impressed on high-voltage transmission lines to carry one or two analog voice circuits, as well as telemetry and control circuits with an equivalent data rate of a few hundred bits per second; however, these circuits can be many miles in length.

2.5.2 RS232

The abbreviation RS232 refers to the "recommended standard number 232." A portion of the RS232 standard is implemented in the majority of computers' serial ports. The complete RS232 standard calls for a "D" connector with 25 pins, but only 22 of those pins are actually used. The majority of these pins are not required for typical PC communications. As a matter of fact, the vast majority of brand-new personal computers come with male D-type connectors that have only nine pins. This configuration sacrifices compatibility with the standard in favor of the use of connectors that are both less expensive and more space-efficient.

RS232 calls the devices that communicate with one another Data Terminal Equipment (DTE), and it calls the devices that communicate with one another Data Communication Equipment (DCE). The DTE is an end instrument that uses the male connector and either converts user information into signals or re-converts signals received. It does one of these two things. The Data Terminal Equipment, or DTE, is the functional unit of a data station that serves as either a data source or a data sink. Additionally, the DTE is responsible for ensuring that the data communication control function is carried out in accordance with the link protocol. While the DCE is a communication link control device that supplies the clock signal and employs the female connector, it is also responsible for controlling the connection. In contrast, the DTE closes the communication line while the DCE opens up a channel for communication to take place. A direct pin-for-pin connection is utilized in the process of connecting a DTE device to a DCE component. Nevertheless, they transmit and receive lines will need to be crossed in

order to connect two DCEs or DTEs. In most cases, a computer or other type of terminal device serves as the DTE, while a modem is utilized as the DCE.

2.5.3 Ethernet

The physical connection of two or more devices is accomplished through the use of Ethernet, which specifies a number of wiring and signaling standards. The original concept behind Ethernet was for computers to communicate with one another through the use of a shared coaxial cable that acted as a broadcast transmission medium. Although there are fundamental differences, the methods that were used show some similarities to radio systems. One of these differences is the fact that it is much simpler to detect collisions in a cable broadcast system as opposed to a radio broadcast. The communication channel that was provided by a common cable was compared to the ether, and it was from this analogy that the name "Ethernet" was derived (Wikipedia, 2009). Ethernet, which was initially a relatively straightforward concept, eventually developed into a sophisticated networking technology that is now the backbone of the majority of local area networks. Point-to-point links connected by Ethernet hubs and/or switches have been installed in place of the coaxial cable in order to cut down on the costs of installation, improve reliability, and make point-to-point management and troubleshooting possible. The transition of Ethernet from a coaxial cable bus to a hub-managed, twisted-pair network began with StarLAN. StarLAN was the first step in this evolution. The introduction of twisted-pair wiring resulted in a significant reduction in the costs associated with installation in comparison to other competing technologies, including the older Ethernet technologies. Ethernet stations communicate with one another by sending data packets, which are blocks of data that are individually sent and delivered. This takes place over the physical connection between the stations.

Even though Ethernet has undergone significant evolution, from a thick coaxial cable bus operating at 10 Mbits/s to point-to-point links operating at 1 Gbits/s and above, all generations of Ethernet (with the exception of early experimental versions) share the same frame formats (and, consequently, the same interface for higher layers), and they can be readily interconnected with one another. And because of the pervasiveness of Ethernet, the ever-falling cost of the hardware required to support it, and the decreased panel space needed by twisted pair Ethernet, the majority of computer and laptop manufacturers now build the functionality of an Ethernet card directly into the motherboards of these devices, eliminating

the need for the installation of a separate network card. This is because Ethernet is so widely used.

2.5.4 Bluetooth

Bluetooth is an open wireless protocol that enables devices, both fixed and mobile, to communicate and exchange data over short distances, thereby creating personal area networks (PANs). It was initially conceived as a cordless replacement for RS232 data cables but later evolved into its current form. It is possible to connect multiple devices, which eliminates the need to worry about synchronization issues. It is a standard as well as a communications protocol that was primarily designed for low power consumption. It also has a short range (1 meter, 10 meters, or 100 meters depending on the power class), and it is based on low-cost transceiver microchips that are embedded in each device. When devices are within Bluetooth range of one another, they are able to communicate with one another and share data. Due to the fact that the devices use a radio (broadcast) communications system, it is not necessary for them to be in direct visual contact with one another.

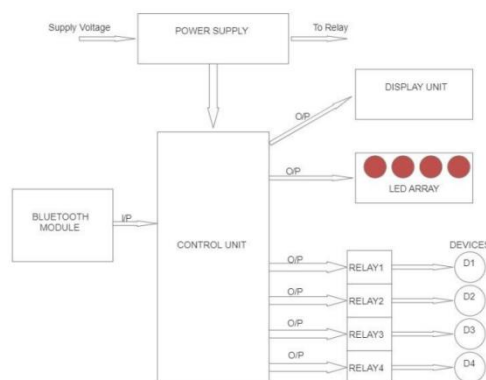

Fig. 2.3 –Bluetooth based home automation

Bluetooth makes use of a radio technology known as frequency-hopping spread spectrum, which breaks up the data that is being transmitted into chunks and sends those chunks over a range of frequencies that can reach up to 79. The modulation, in its most fundamental form, makes use of the Gaussian frequency-shift keying technique (GFSK). It is capable of achieving a raw data rate of one megabit per second. Bluetooth is a wireless technology that enables electronic devices such as mobile phones, telephones, laptops, personal computers,

printers, Global Positioning System (GPS) receivers, digital cameras, and video game consoles to connect with one another and share information via a safe, globally unlicensed short-range radio frequency band known as the Industrial, Scientific, and Medical (ISM) band operating at 2.4 GHz. The Bluetooth Special Interest Group is responsible for the development of and licensing of the Bluetooth specifications (SIG). Companies specializing in telecommunications, computing, networking, and consumer electronics are represented in the Bluetooth Special Interest Group (SIG) (Wikipedia, 2009).

2.5.5 Infrared

Infrared (IR) radiation is a type of electromagnetic radiation that has a wavelength that is shorter than that of microwave radiation but longer than that of visible light (400 - 700 nm). It is used for short-range communication among devices that are following the standards published by the Infrared Data Association and has a wavelength that ranges from 750 nanometers to 100 micrometers (IrDA)

Infrared light-emitting diodes, also known as LEDs, are used in IrDA devices such as remote controls. These LEDs emit infrared radiation, which is then focused by a plastic lens into a narrow beam. In order to encode the data, the beam is modulated, which means it is alternately turned on and off. In order to transform the incoming infrared radiation into an electric current, the receiver makes use of a silicon photodiode. It is only sensitive to the rapidly pulsing signal that the transmitter generates, and it filters out the gradually shifting infrared radiation that comes from the surrounding light. The use of infrared communications is beneficial for indoor use in locations with a high population density. Because infrared light cannot pass through walls, it will not disrupt the operation of other electronics in rooms that are adjacent to it. The transmission of commands from remote controls to home appliances is almost always done through infrared.

2.5.6 GSM

The Global System for Mobile Communication (GSM), which is the most widely used standard for mobile phone communication anywhere in the world, can be abbreviated as "GSM." It is utilized by over three billion people in in excess of 212 countries and territories across the world (Wikipedia, 2009).

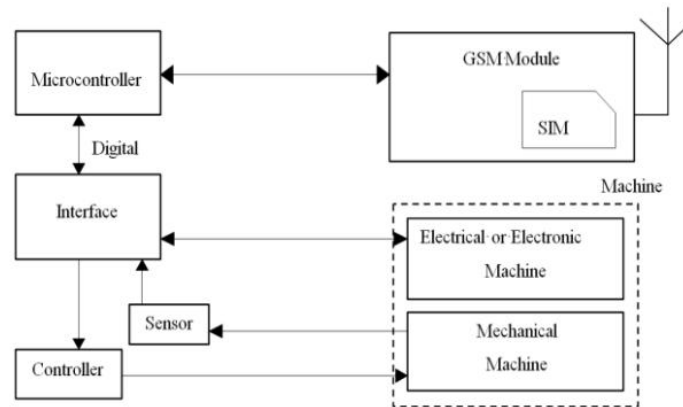

Fig. 2.4 – Mobile based home automation

GSM is primarily responsible for voice calling and the delivery of short messages (SMS). It functions as a cellular network, and mobile phones can connect to it by looking for other cells in the immediate area in order to establish a connection. Gaussian minimum-shift keying, also known as GMSK, is the kind of modulation that is used in GSM. It is a kind of continuous-phase frequency shift keying. Before being fed into a frequency modulator, the signal that is going to be modulated onto the carrier in GMSK is first smoothed with a Gaussian low-pass filter. This helps to significantly reduce the interference that is caused to neighboring channels (adjacent channel interference). The majority of countries around the world use either the 900 MHz or 1800 MHz frequency bands for GSM network operation. However, there are a few countries, such as the United States and Canada, that use the 850 MHz and 1900 MHz bands instead because the 900 MHz and 1800 MHz bands are already in use. GSM technology makes use of radio frequency channels with a bandwidth of 200 kHz that are time-division multiplexed. This allows for as many as eight users to access each carrier simultaneously.

2.5.7 Microcontroller

A microcontroller is a single-chip computer that is relatively inexpensive. The term "single-chip computer" refers to a type of computer in which the entirety of the computer system is contained within a single integrated circuit chip (Byte, 2002). The microcontroller that is contained within the silver of silicon encapsulation has features that are comparable to those of a typical personal computer. Its capacity to both store and executes one-of-a-kind programs gives it a high degree of versatility, and its ability to perform mathematical and logical operations enables it to simulate complex electronic and logical circuits.

Microcontrollers can be found in a wide variety of products and devices that can be controlled automatically. Some examples include the engine control systems found in automobiles, remote controls, office machines, appliances, power tools, and toys. As a result, microcontrollers do not operate in isolation; rather, they take input from one or more devices and then send that output to other microcontrollers that are part of the same system. In point of fact, they are accountable for the intelligence found in the vast majority of intelligent devices available on the consumer market.

Both the microcontroller's mode of operation and its overall design can be characterized by one of two general architecture types.

2.5.7.1 Von-Neuman Architecture

In this particular architecture, data and program instructions are kept in a single memory space that is shared by the entire system. There is only one data bus, and it is responsible for fetching both data and instructions. In addition, each time the central processing unit retrieves a program instruction, it may be necessary for it to carry out a number of read/write operations on the data memory space. It is necessary for it to wait until these subsequent operations are finished before it is able to fetch and decode the following instruction from the program. The benefit of this architectural design is that it is both straightforward and cost-effective. On some machines that use the Von Neumann architecture, the program has the ability to read from and write to the CPU registers, including the program counter. This can be risky because it allows the processor to be pointed to memory blocks that are outside of the program memory space. Additionally, careless manipulation of the processor can cause errors that require a hard reset to be performed.

2.5.7.2 Harvard Architecture

This architecture uses distinct memory areas for the storage of program instructions and data respectively. There are at least two and possibly more internal data buses, each of which enables simultaneous access to data as well as instructions. The central processing unit accesses the program memory bus in order to retrieve instructions. If the instruction that was fetched needs to perform an operation on data memory, the central processing unit (CPU) can retrieve the next program instruction while it uses the data bus for the operation that it needs to perform on the data. These reduce the amount of time required for the execution of code

but increase the complexity of the required hardware. The Harvard architecture can be found in the vast majority of modern microcontrollers. (Wikipedia, 2009).

2.6 CONCEPT AND PRINCIPLE OF IOT BASED AUTOMATION SYSTEM

An automated home is also referred to as a "smart home" on a global scale. A smart home is a home that is automated and can be controlled remotely from a mobile device or computer from any location on the planet. It is designed to conserve both the energy used by humans and the electric power. The system that is being proposed is a decentralized home automation system, and it is comprised of a server, a Wi-Fi module, and sensors. The server is in charge of controlling and monitoring all of the different sensors, and it can be easily configured to deal with additional hardware interface modules (sensors). Web server functionality is provided by the Arduino board, which features an integrated Wi-Fi module. Access to the Automation System can be gained locally through the web browser of any local personal computer by using the server IP, or it can be gained remotely through the web browser of any personal computer or mobile handheld device that is connected to the internet and has the appropriate web browser (internet IP). It has been decided to use Wi-Fi technology as the infrastructure for the network that will connect the server to the sensors. Wi-Fi was selected because it enables greater system mobility and scalability, as well as improved system security (via the utilization of a secure Wi-Fi connection).

2.7 COMPONENT USED

2.7.1 TRANSFORMER

Electrical Transformers are stationary devices that consist of two or more coils of wire and are used to transfer electrical energy by means of a changing magnetic field. Transformers can be either single- or three-phase. A transformer is an electrical device that changes the value of electrical energy from one form to another according to the principles outlined in Faraday's law of induction. This is made possible by connecting at least two separate electrical circuits through the utilization of a single oscillating magnetic circuit that is generated by the transformer.



Fig.2.5 - Transformer

OPERATION PRINCIPLES OF TRANSFORMER

Transformers use the principle electromagnetic induction such as mutual induction to perform their functions. A magnetic field from one coil wire can generate a voltage in another coil that is in close proximity to them through a process called mutual induction. The voltage and current of an electrical supply can be increased or decreased by using a transformer, but the frequency and amperage of the electricity can remain the same. The "winding" of a single-phase transformer is made up of two electrical coils of wire. The two sets of winding; primary and secondary. Both coils are wound independently around a closed magnetic iron "Core," though, Lamination are bonded together to form the core, which helps to lessen magnetic losses.

It is possible to determine the voltage induced across the secondary coil using Faraday's law of induction, which stipulates that:

$$V_s = N_s d\Phi/dt \dots \dots \dots (1)$$

Where;

Where V_s is the secondary coil's instantaneous voltage, N_s is the coil's number of turns, and Φ is the magnetic flux across a single turn of the coil. The flux is equal to the product of the magnetic flux density B and the area A through which it passes if the coil's turns are aligned at right angles to the magnetic field lines. While the magnetic field changes over time in response to the excitation of the primary, the area remains constant and is equal to the cross-sectional area of the transformer core.

An ideal transformer has a primary and secondary winding that share the same magnetic flux, so the voltage across the primary at any given moment is equal to the voltage across the secondary at the same moment.

$$V_p = N_p d\Phi/dt \dots\dots\dots(2)$$

Taking the ratio of the two equations for V_s and V_p gives the basic equation for stepping up or stepping down the voltage

$$V_s/V_p = N_s/N_p \dots\dots\dots(3)$$

The turn ratio, denoted as N_p/N_s , is the most important operational feature of any transformer. This is sometimes written as the reciprocal, N_s/N_p , when referring to step-up transformer. The Transformer used for this project is a 12V 1.5Amp transformer. The 12volt transformer was used to step down the 220v from the AC source to a voltage of 12volt/1.5A

2.7.2 RECTIFIER

Rectifier is an electrical device that converts AC current which reverses its direction periodically into DC current which flows in one direction. The AC current from the 12volts transformer is then pass through the rectifier which converts it into a dc output.

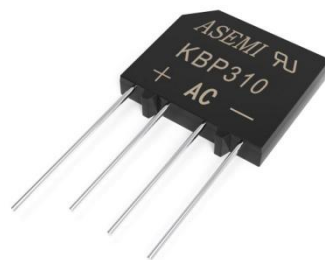

Fig.2.6-Rectifier

2.7.3 FILTER CAPACITOR

The dc voltage from the rectifier is pulsating as discuss above so to avoid having a pulsating dc voltage a Capacitor filter is connected in parallel with the output being filtered in this project a 1000 μ f.



Fig. 2.7-Filter Capacitor

2.7.4 REGULATOR

Regulators are linear integrated circuits used to provide a regulated constant output voltage. We do not need a voltage change in output voltage. There are two types of voltage regulator; Switching (DC-DC converter), Linear (Low-dropout regulators). The regulator used for this project is the Switching regulator (DC-DC converter which is discussed in the following section.

2.7.4.1 DC-DC CONVERTER

This is the type of regulator used in the power supply of this project, it was used to regulate the non-pulsating 12 volts DC voltage to 5 volts DC voltage which is required to power the



system.

Fig.2.8-DC-DC Converter

DC-DC converter was used in this project because;

- It is more efficient.
- It has a large load current. The minimum current required for the micro controller to operate is 1amp and this is produced from the output of the dc-dc converter unlike the Low dropout regulator.

2.7.5 MICRO CONTROLLER

The Esp32-wroom is a powerful, general Wi-Fi + BT(Bluetooth) Micro-controller module that is used for this project. This micro-controller is designed to target a large range of electrical applications, from low-power sensor networks to the most demanding jobs



Fig.2.9-Esp32-wroom

Specifically, the ESP32-D0WDQ6 chip is the brains of this module. The included chip was developed with scalability and flexibility in mind. The CPU has two independently tunable cores, and its clock speed ranges from 80 to 240 megahertz.

The chip also has a low-power co-processor that can be used instead of the CPU to save power while performing tasks that do not require much computing power, such as monitoring of peripherals

2.7.5.1 IMPORTANT FEATURES OF ESP32-WROOM

The ESP32-D0WDQ6 has two low-power Xtensa 32-bit LX6 microprocessors. Internal memory which contains the following:

- A total of 448 KB of ROM for booting and core functions.
- 520 KB of SRAM on-chip for data and instructions
- RTC FAST Memory, which is 8 KB of SRAM and can be used for data storage; it is accessed by the main CPU during RTC Boot from Deep-sleep mode.
- 8 KB of SRAM in RTC, known as RTC SLOW Memory, which can be accessed by the co-processor while in Deep-sleep mode. (*Esp32-wroom-32_datasheet_en V24*)

2.7.5.2 REASONS FOR SELECTING ESP32-ROOM FOR THIS PROJECT

- The versatility and broad applicability of the module are guaranteed by its incorporation of both Bluetooth Low Energy and Wi-Fi radios. Bluetooth allows the user to quickly connect to the phone or broadcast low energy beacons for its detection, while Wi-Fi provides for a wide range of physical movement and a direct connection to the Internet via a Wi-Fi router.
- The ESP32 chip's sleep current is less than 5 μ A, making it appropriate for battery powered and wearable electronics applications. To provide the greatest physical range, the module supports a data rate of up to 150Mbps and an output power of 20dBm at the antenna. As a result, the module has industry-leading specs and the best performance in terms of electronic integration, range, power consumption, and connectivity.

Esp32-wroom-32_datasheet_en V24)

2.7.5.3 POWER REQUIREMENT

The Esp32-wroom board usually operates between 2.2V to 3.6V but we supply 5V. There is an internal 3.3 voltage regulator to keep the voltage steady at 3.3V. The ESP32 can be powered via the VIN pin (External Supply Pin).

ESP32 requires 600mA of power. It draws up to 250mA during RF transmission and also draws over 200mA during boot or Wi-Fi operation. When we add numerous sensors or modules to the ESP32 Board, the power supplied through the Micro-USB Cable is not sufficient to power the board. This is because a computer USB connection can only give 500mA of current or less.

2.7.5.4 ESP32 PINS

The Esp32 has 48 GPIO pins but not all pins are exposed on the board and some cannot be used. The Esp32 has 30 GPIO pins which is visible on the board and has 25 GPIO pins which can be assigned to various functions. These pins are listed below;

Usable GPIO pins: D4 D13 D14 RX2 TX2D18 D19 D21 D22 D23 D25 D26 D27 D32 D33

VIN: is the input pin it cannot be configured as an output pin. It is the power pin of the board

GND: is the ground pin

2.7.6 RELAYS

Relays are electrically operated switch. They consist of input terminals for a multiple or single control signal. The relay uses an electrical signal from the Esp32 micro-controller to control an electromagnet which in turn connects or disconnect another circuit.

Relay has five (5) terminals namely; Normally open, normally closed, two coils and the common.



The relay used in this project is the 12V/ 10Amp relay

Fig.2.10-Relays

2.7.6.1 OPERATING PRINCIPLES OF THE RELAY

The Common of the relay is connected to the neutral from the power source. Electrical signal is passed into to the two coils connected to a transistor which is connected to the Esp32-wroom, by default the Common is in contact with the Normally close. When electrical signal is passed through the coils this causes the Common to contact the Normally Open.

2.7.7 TRANSISTORS

Transistors are semiconductor device that are used conduct and insulate electric voltage or currents. It acts as switch and also as an amplifier. They are used to control or regulate flow of electrical signals. The transistor used for this project is the NPN transistor (BC547).

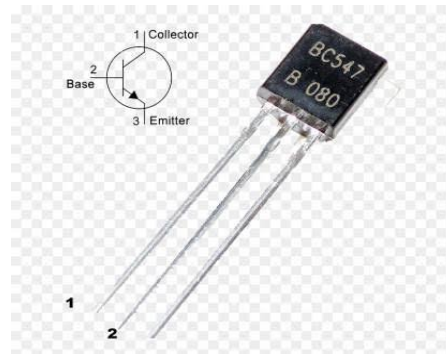

Fig.2.11-Transistors

2.7.8 DIODES

Diodes are two (2) terminal electronic device that conducts current in one direction. It has a low resistance in one terminal and a high resistance in the other. The diode can be used to convert AC to Dc electrical energy. It can also be used to prevent DC current from reserving in one direction (back feed DC current).

For this project, the diode was used to prevent the DC current entering the coil from flowing back to the transistors, since current in diode flow in one direction.

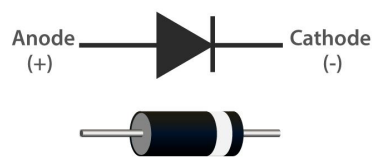

Fig.2.12-Diodes

CHAPTER 3

METHODOLOGY

3.1 INTRODUCTION

This chapter covers the project's analysis, selection of the materials and components, circuit design, and calculations.

3.1.1 SYSTEM DESIGN AND OPERATION (BLOCK DIAGRAM)

This section shows a block diagram to give a virtual representation of how the project will look like

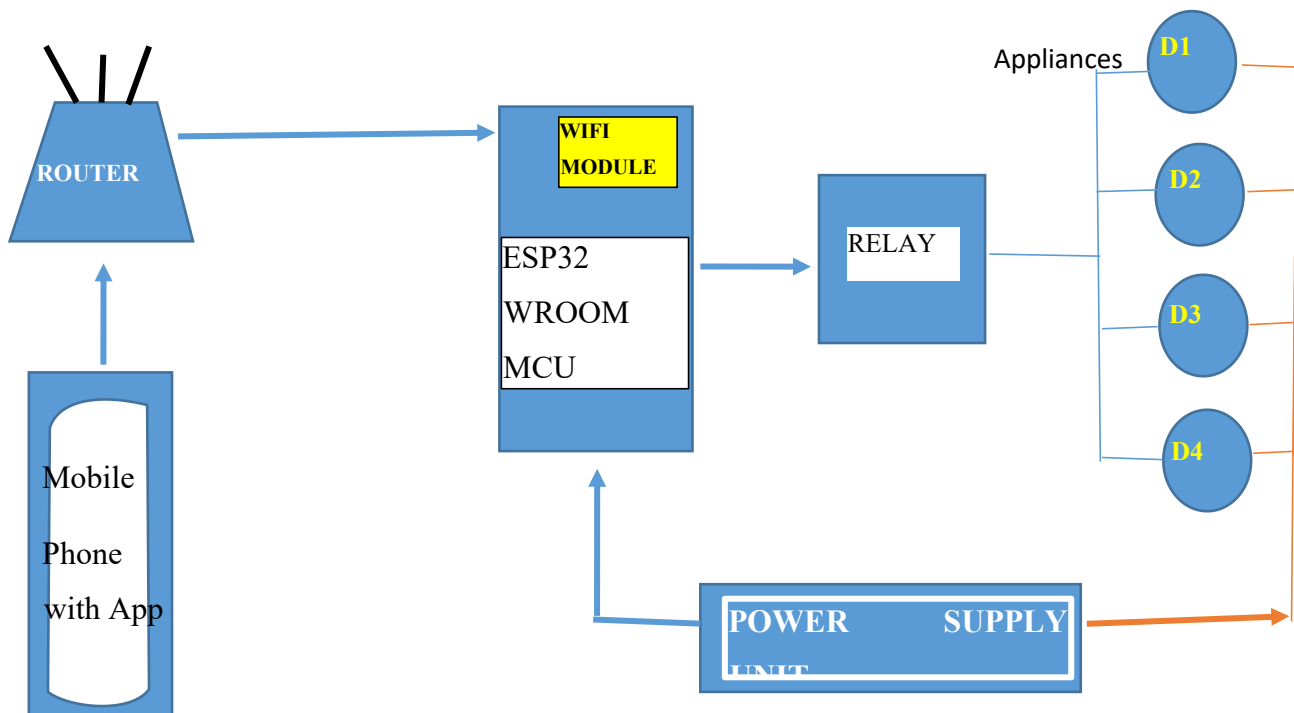

Fig.3.1-Block diagram of the smart home automation system

The block diagram above illustrates the schematic connection of the various components, which include the micro controller (ESP32-WROOM), relays, router, and mobile app (Blynk app).

3.2 POWER SUPPLY UNIT

One of the major units in the smart home automation system is the power supply unit. A 220V-50Hz AC supply is delivered to the circuit, while the Esp32-wroom needs a 5V DC supply. In order to achieve this, various electrical components are set up, including the transformer, rectifier, regulator, and capacitors. There is a need to convert from AC to DC and step down the voltage to 5V input voltage.

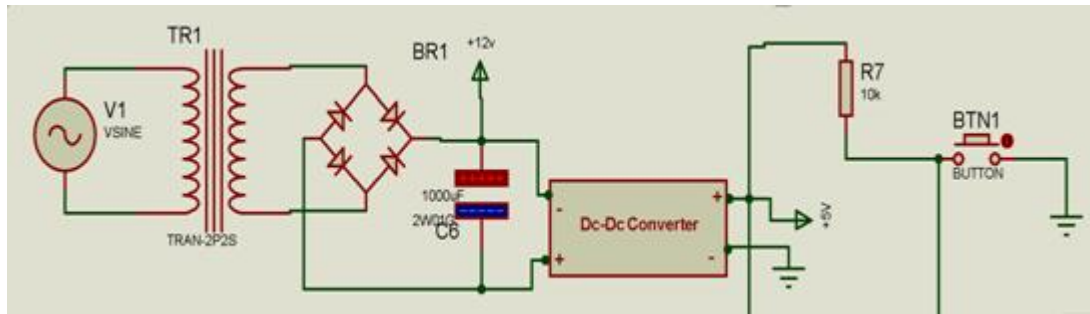

Fig 3.2-Power Supply Unit.

3.2.1 FILTER CAPACITOR

A Capacitor filter is connected in parallel with the output being filtered in this project a 1000µf.

CALCULATION FOR CAPACITOR USED

$$C = \frac{I \times T}{v} \dots \dots \dots (1)$$

C = capacitance

I = maximum output current (1000mA)

T = 10ms

V = peak voltage – voltage given to voltage regulator (12v)

Peak voltage = $V_{rms} \times 1.414$

$V_{rms} = 12v$

Therefore;

$$V = 12 \times 1.414 = 16.97v$$

Voltage drop each diode is 0.7 therefore as two diodes will be forward biased voltage drop will be ($2 \times 0.7 = 1.4$)

Therefore $16.97 - 1.4 = 15.57\text{v}$

When the capacitor discharges it must provide 7v DC to the regulator to work so therefore

$V = 15.57 - 7 = 8.57\text{v}$

$$C = \frac{1000 \times 10}{8.57} = 1166.86\mu\text{f}$$

1166.86 μf is a close value to 1000 μf therefore a capacitor of capacitance 1000 μf is suitable for this purpose.

3.2.2 TRANSISTORS

The transistor used for this project is the NPN transistor (BC547).

CALCULATION FOR TANSISTOR USED

$$I_B = 5\text{mA}$$

$$R_B = ?$$

$$V_{CC} = 5\text{V}$$

$$V_D = 0.7\text{V}$$

$$R = \frac{V_{CC} - V_D}{I_B} \dots\dots\dots(2)$$

$$R = \frac{5 - 0.7}{5 \times 10^{-3}} = 860\Omega$$

This shows that the base resistor should not be less than 860 Ω therefore we used 1K Ω since its the closest common value.

3.3 SOFTWARE APPLICATION

- **Blynk Application:** Allows us to develop stunning interfaces for your projects by utilizing the numerous widgets supplied.
- **Blynk Server:** Handles all communications between the smartphone and the hardware You can use our Blynk Cloud or set up your own private Blynk server. It's free source, can manage thousands of devices, and can even run on a Raspberry Pi.
- **Blynk Libraries:** Enable communication with the server and handle all incoming and outgoing commands for all popular hardware platforms. When a radio button in the Blynk application is pressed, a message is sent to the Blynk Cloud, where the unique

generated authentication token locates the exact hardware. It operates in the opposite direction as well.

3.4 SETTING UP THE SYSTEM

- The micro controller is programmed on an Arduino IDE (Integrated Development Environment) with commands to assign each pin of the Esp32 to the corresponding relays.
- Go to the web platform of Blynk (<https://blynk.io>) then create an account.
- After logging-in, start a new project.
- The project is given a name. The name given for this project is “Smart Home”,
- the hardware is selected as Esp32, the connection type is set as Wi-Fi then the project is created.
- This project uses a six (6) channel relay so six (6) buttons are dragged and dropped from the side bar to control each of the relays.
- Rename each button with same name corresponding to each digital pin when the micro-controller was programmed.

Table 3.1-Configuration of The Blynk Mobile Application

NAME	RELAY	APPLIANCE
DEVICE_1	RELAY 1	SOCKET
DEVICE_2	RELAY 2	SOCKET
DEVICE_3	RELAY 3	SOCKET
DEVICE_4	RELAY 4	BULB
DEVICE_5	RELAY 5	BULB
DEVICE_6	RELAY 6	BULB

- The Blynk application is downloaded from Google Play Store and then installed on the smart phone (infinix smart6, 2GB ram, 1.6GHz Octa-Core).
- Once the Blynk application installation is completed, the account created on the web is then logged-on the mobile application.
- The Blynk application setup is now complete.

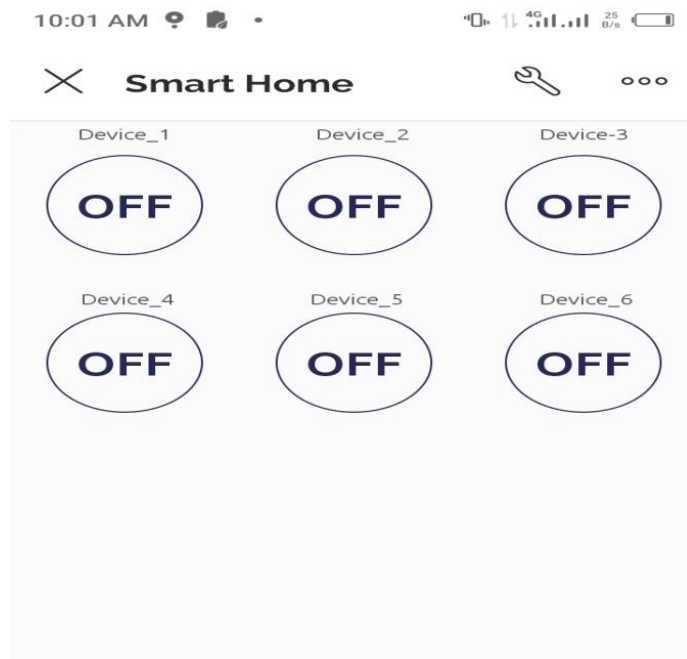

Fig.3.3-BLYNK Application Interface

- Another smart phone device is used as a router for this project to provide the Wi-Fi module a stable internet connection to the server for commands and updates.
- The hot-spot from the other device is first turned on and its password and username are customized to correspond to that which was used in the programming of the Esp32 micro-controller.
- The data connection on the other smart phone is turned on and the Wi-Fi module on the Esp32 board easily discovers the hot spot and connects automatically.
- When a button (DEVICE_1 for example) from the Blynk application is toggled ON, this sends the command to the server to update the state of RELAY 1 which then turns on the SOCKET.

3.5 HARDWARE ASSEMBLING AND PRINCIPLE OF OPERATION

A detailed explanation of the hardware assembling from the power supply unit to the appliances is given in figure 3.12 below. The principle of operation of the entire system is also described in this section;

- The 12V/1.5Amps transformer is supplied an AC voltage of 220V and this transformer steps down this voltage and delivers 12V AC.
- The 12V AC from the transformer is then converted to a DC voltage with the rectifier, the rectifier produces a pulsating 12V DC voltage.
- A capacitor of rating 1000uf/35V is used to filter the current to produce a non-pulsating dc current.
- The connection is made from the rectifier through the capacitor then to the switch regulator (DC-DC converter which in turn converts the 12V DC volt to a 5V DC voltage and 1Amps.
- 5V/1A from the regulator module is connected to the Esp32-wroom board through the VIN pin which supplies power to the ESP32 chip for operation.
- The output from the Esp32 GPIO pin is connected to a 1k Ω base resistor to limit excessive current to the base of the transistor.
- A transistor is connected to the coils of the 12V/10A relays and a diode is connected between the coil and the terminal of the transistor to avoid back flow of currents.
- The Common of the relays are connected to the neutral from the AC supplied voltage.
- Normally open terminal of the relay is connected to one terminal of the appliance. When there is an electrical signal the Common moves to the normally open and allows current to flow through to the appliance.
- The electric live wire from the power source is connected directly to one terminal of the appliance.
- For this project we have a prototype of six (6) home appliance which includes three (3) lamp holders with light bulbs and three (3) wall sockets.

3.6 CIRCUIT DIAGRAM

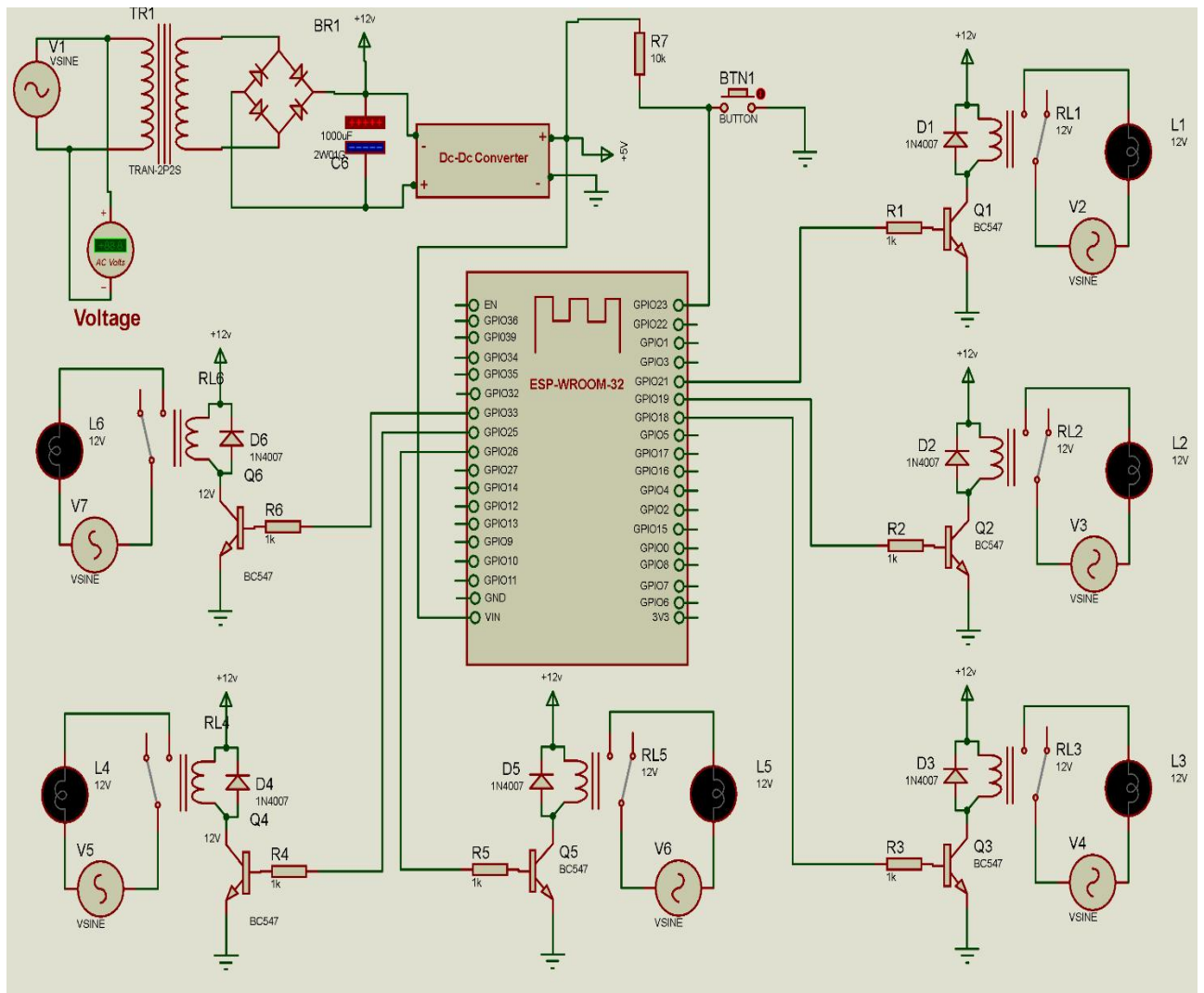

Fig 3.3-Circuit diagram of home automation system

CHAPTER 4

CONSTRUCTION, TESTING & RESULT

4.1. CONSTRUCTION

The circuit diagram was the first step in the actualization of the project, after much consideration and calculation had been carried out with respect to components bought.

Considerations included:

- i). Power Supply
- ii). Resistance of the resistors
- iii). Capacitance of the capacitor

Also, the workability of all other discreet components was verified before proceeding to pre-testing of some key components such as Power supply circuit, working and clicking relays on a breadboard. After this verification on the breadboard, we proceeded to the Vero-board.

The components for each section were assembled and soldered on a Vero-board. The power supply unit was built first followed by the input unit, control unit and lastly the output unit.

The power supply unit was tested and the expected voltage of 5VDC were achieved as expected. The output from the input unit was connected to the microcontroller (Esp32 w-room).

The main circuit was enclosed in a plastic casing to avoid short circuit, protect the components and ensure longevity.

4.2. TOOLS USED

The major tools used to ensure smooth and tested construction of the project are listed below:

- i. Soldering iron
- ii. Soldering lead
- iii. Pliers
- iv. Solder sucker
- v. Wire cutter
- vi. Hand Saw
- vii. Multi-meter

4.2.1. Soldering Iron and Soldering Lead

The soldering iron was mostly used in melting the soldering lead to ensure components like the relay, diode, IC setters and the microcontroller were firm on the Vero-board as well as joining wires etc.

4.2.2. Vero-board

Vero-board is the panel/board in which most of the soldering was carried out, and various components were placed on top. The board consists of holes which are arranged in matrix format. One of the important things to note while working with a Vero-board is:

- ❖ All the holes are connected (there is continuity) which can spoil the whole circuit and component, thereby we manually have to use a sharp object to cut the continuity on the board when connecting components that do not require continuity or connection and use jumper wires where necessary.

4.3. TESTING

Testing is one of the important stages in the development of any new product or repair of existing ones. It is a good design practice to always bread-board a circuit first and test its output before soldering on Vero-board since it could be difficult to trace faults in a finished work especially a complex circuit like ours. In the case of this project, we carried out two stages of testing:

- I. Pre-implementation testing
- II. Post-implementation testing

4.3.1. PRE-IMPLEMENTATION TESTING

1. Transformer

Firstly, continuity test was carried out in the transformer to check whether there is a short circuit or open circuit.

2. Voltage Regulator (7805)

Continuity test was carried out on this component and the following result was obtained as shown below:

Table 4.1 – Result Of Voltage Regulator Test

+/-	IN	GROUND	OUT
IN	---	HIGH	LOW
GND	LOW	---	LOW
OUT	LOW	HIGH	---

3. Diodes

A forward and reverse bias test was carried out on the diode.

4. Relay

With the use of a 12V battery, we were able to determine the state of the relay and its ability to click.

4.3.1.1. MOUNTING AND CONNECTION OF COMPONENTS

Most connections were made by soldering on the Vero-board or directly by the use of wire.

The following considerations were covered while working:

- The tip of the soldering iron was ensured to be to prevent continuity where not necessary.
- The space between each component considering the size of the casing we propose to use.
- A very thin and good soldering lead was used ensure melting of the lead with minimal heat.
- We tried our possible avoid soldering a component for a very long time to prevent damages.
- A multimeter was very handy for carrying out different test during the cause of the mounting test like: Insulation test, Continuity test. It was also used Voltages, Current and Resistance measurement at certain part and connection.

1. Circuit Board

Vero-Board was used for the physical connection of this project. Great care was taken to ensure that components were placed properly as designed in the circuit diagram. The components were soldered after placement was done to ensure firm connection. After all components are being soldered continuity test was carried out in between the lines of each component, to ensure there were no bridged lines or same potential of components not meant to be the same.

This was very important and necessary to avoid short circuit or flashing of component.

2. Power Supply Unit (PSU)

The Transformer T1 (240/12V) transformer was placed on the Vero-board, the wires for the High Voltage (H.V.) and the Low Voltage (L.V.) terminals were taken through the holes of the board and soldered under the board, the High Voltage (H.V.) terminals received the Live (L) and Neutral (N) from the main power source.

The Bridge Rectifier was placed closed to the transformer and its A.C inputs were soldered to the L.V side of the transformer, after this the filter capacitors, The Voltage Regulator (7805) which produces the 5volts.

3. Microcontroller (Esp32 WROOM)

A 40 pin IC Socket was placed on the board and soldered, we ensured all the pin was properly soldered, the firm soldering made it easy to remove and put the microcontroller

4.3.2. POST-IMPLEMENTING TESTING

After forming the circuit on the Vero-board, the different sectors of the complete system was tested to ensure every component was in good working condition for the project.

Proper calculations were done to ensure the workability and load management was done. Due to the calculations, we were able to know the certain ratings of component to buy in the market to enable us get the maximum workable condition of the project.

The Circuit was double checked with the use of the multi-meter for proper continuity and when needed, a sharp object was used to cut the back of the vero-board to break the

continuity. This is to ensure the circuit is in good working condition and the components are properly linked together as shown in the circuit diagram, all this was carried out before power was given to the power supply unit and then to the whole board.

4.4. TESTING OF PROTOTYPE

At the completion of the project, we had a total of 6 outlets namely;

- 13A Sockets (*3)
- Lamp holders (*3).

These outlets representing load appliances for the system were installed, plugged and tested with result obtained.

The table below shows the results obtained during a certain duration of the project being ON (that is the circuit being powered). The circuit was tested for a day.

NOTE: Heavy appliances (Microwaves, Pressing Iron etc.) cannot be plugged on the device as it could damage the corresponding relay. Therefore, a contactor can be used in place of the relay for heavy appliances.

RESULTS FOR PROTOTYPE TEST

Table 4.2 – Device 1,2,3 (13A Socket)

DATE	POWER STATUS	START	END	DURATION (Mins)	Device 1 STATE	Device 2 STATE	Device 3 STATE
26/11/2022	Power Supply	12:00am	6:00am	360	ON	ON	ON
	Power Outage	6:00 am	2:00pm	480	OFF	OFF	OFF
	Power Supply	2:00pm	6:00pm	240	ON	ON	ON
	Power Outage	6:00pm	9:00pm	180	OFF	OFF	OFF
	Power Supply	9:00pm	10:00pm	60	ON	ON	ON
	Power Outage	10:00pm	12:00am	120	OFF	OFF	OFF
27/11/2022	Power Supply	12:00am	7:00am	420	ON	ON	ON
	Power Outage	7:00am	2:00pm	420	OFF	OFF	OFF

	Power Supply	2:00pm	5:00pm	180	ON	ON	ON
	Power Outage	5:00pm	7:00pm	120	OFF	OFF	OFF
	Power Supply	7:00pm	10:00pm	180	ON	ON	ON
	Power Outage	10:00pm	12:00am	120	OFF	OFF	OFF

Table 4.3 – Device 3,4,5 (Lamp Holder With Load)

DATE	POWER STATUS	START	END	DURATION (Mins)	Device 4 STATE	Device 5 STATE	Device 6 STATE
26/11/2022	Power Supply	12:00am	6:00am	360	ON	ON	ON
	Power Outage	6:00 am	2:00pm	480	OFF	OFF	OFF
	Power Supply	2:00pm	6:00pm	240	ON	ON	ON
	Power Outage	6:00pm	9:00pm	180	OFF	OFF	OFF
	Power Supply	9:00pm	10:00pm	60	ON	ON	ON
	Power Outage	10:00pm	12:00am	120	OFF	OFF	OFF
27/11/2022	Power Supply	12:00am	7:00am	420	ON	ON	ON
	Power Outage	7:00am	2:00pm	420	OFF	OFF	OFF
	Power Supply	2:00pm	5:00pm	180	ON	ON	ON
	Power Outage	5:00pm	7:00pm	120	OFF	OFF	OFF
	Power Supply	7:00pm	10:00pm	180	ON	ON	ON

	Power Outage	10:00pm	12:00am	120	OFF	OFF	OFF
--	-----------------	---------	---------	-----	-----	-----	-----

4.4.1 TESTING OUTLINE

Load where connected to the 13amps socket.

- At Device1 a phone charger was plugged in.
- At Device 2 a standing fan was plugged to the circuit.
- At Device 3 it was left blank

Device 1:When there was power supply from 12:00am to 6:00am it was able to charge up a Redmi Note 9(3.8Volts) to 100% without basically overheating and basically no side effect. The power outage from our table are basically because of two reasons (i) The system or the socket was turned off (ii) There was no light to power the system.

Device 2:The standing fan was plugged to the circuit and it worked when there was supply given without any effect like heat e.t.c

Device 4,5,6: A fluorescent bulb of 9 watts was plugged to the circuit and all three lamp holders with the bulbs lit up during the duration of the power supply. So basically, the entire project worked perfectly.

Table 4.4-Displaying outage for daily supply

Date	Power Outage (mins)
26/11/2022	780
27/11/2022	660

FAILURE RATE (λ)

Failure rate is the number of failures which occurs per unit in a given time interval. It is expressed as

Failure rate (λ) = *number of failure*/total operating time of units

Total operating time of units = number of units – hours of operation

MTTF = 1/failure rate

Reliability

Reliability can be defined as the probability that a device/ system will function correctly when required to act, while availability is that, system will be able to perform its required function over a specific period of time.

Reliability (R) = $e^{-\lambda t}$

Where λ = failure rate

t = time of outage

Table 4.5-Reliability table for power outage

Date	Frequency	Outage Time(min)	MTTF(MIN)	Failure Rate	Reliability (%)
26/11/2022	3	780	480.77	0.0021	1.08
27/11/2022	3	660	480.77	0.0021	1.33

4.5. COUPLING

In the coupling of the project, we used a plastic casing and the circuit was placed inside the casing. The transformer was fastened to the casing with the use of bolt and nut, also the Vero-board was locked to the plastic casing with the use of bolt and nut.

The major reason for using a plastic casing is because it is a very good insulator, so that when there is a bridge it would not affect the board and any human-being in contact with the board.

Finally, after packaging the device was tested and it worked perfectly well.

4.6. PROBLEM ENCOUNTERED

Different problems were encountered during the course of the project which will be highlighted:

- Due to the heat from the soldering iron some component got damaged and needed replacement.
- The project took longer than expected due to power instability and continuous error in writing the code.
- After calculation to get the rating of some components to be used, they were not available in the market, an example being resistors.
- Time was also big challenge in the actualization of the project.

4.7. PRECAUTION

Due to certain problem encountered or from knowledge, certain precaution had to be taken:

- Most Importantly the design circuit was followed accurately
- The work station was well ventilated and no fan was on as it could affect the rate of soldering and the neatness of the soldering.
- The calculation for the rating of the component was done very carefully to avoid damaging any sensitive component with over voltage.

- When soldering we tried as much not to be on a certain component for too long as it may burn the component.
- For the output we tried it with lower demanding voltage devices like torch light to check out working condition of the system.

4.8. BILL OF ENGINEERING MEASUREMENT AND EVALUATION OF QUANTITIES

Table 4.6 List of components Used

S/N	COMPONENT	QUANTITY	PER COST (naira)	TOTAL COST (naira)
1	Microcontroller (Esp32-wroom)	1	10,000	10,000
2	Transistor (BC547)	10	50	500
3	1n4007	10	20	200
4	Crystal (16mHZ)	2	200	400
5	22pF	2	30	60
6	Veroboard	1	400	400
7	28pin IC socket	1	150	150
8	30A Socket	6	700	4,200
9	Lamp Holder	6	300	1,800
10	Electrical wires	5yards	200	1,000
11	Jumper Wires	2yards	200	400
12	AC Voltmeter	1	2,500	2,500
13	Patrex box	1	1,500	1,500

14	Connectors	1	1,000	1,000
15	Board	1	4,500	4,500
16	Nut and Bolt	5	50	250
17	DC-DC converter	1	2,000	2,000
18	12v Relay	6	300	1,800
19	Shipping/Transportation		12,000	12,000

CHAPTER 5

CONCLUSION AND RECOMMENDATION

5.1. CONCLUSION

Design, Construction and implementation of a home automation system was indeed an interesting task to undergo. The beauty of the whole process was to be able to control your small appliances from a distance and also save power consumptions after several process of trail and adjustment.

The project has given us a great insight and practical knowledge of our previous courses like:

- **EEE376 (Programming):** A little insight into programming with languages like C++.
- **EEE591 (Maintenance and Reliability):** this was used to check the reliability of our circuit prototype and maintenance in the sense of packaging.
- **And other electrical and electronic courses** that help us in the calculation of the capacitors and resistance used and the circuit and the desirable current that will flow through certain part of the project circuit.

The ability to know the state of your electronics at your home either 'ON' or 'OFF' while you are away or close by, is of high importance in power engineering regarding consumption of electrical power and saving of electrical unit in Prepaid Meter which is seen around commonly.

5.2. LIMITATION.

Our prototype had some foreseen limitation which could be worked upon. The limitations are stated below:

- Unstable internet connection affects the functionality of the system because of the distance of the Wi-Fi coverage.
- The device connected to the system is limited by capacity of the relay and transformer connected to the system.

NB: A 12volts transformer and 10Amp relay was used.

- Heavy appliances can't be plugged to the system

5.3. RECOMMENDATION AND FUTURE WORKS.

This power system is recommended for every home, office, laboratories, hospital and industries to help in a saving of power unit.

For advancements in certain parts of the project. Certain considerations should be put in place such as:

- Accommodation of heavy appliances. The use of certain rated contactors is very much advisable as it gives space to accommodate the heavy appliances like hot plate, microwaves and pressing iron.
- An application can be coded to interact with the Blynks software which may give a better Wi-Fi coverage.
- A security system may be incorporated into the already existing system.

REFERENCES

1. Sarode, C., Thakar, H. S. (2013). International Journal of Engineering Research and Applications (IJERA) ISSN: 2248-9622 www.ijera.com Vol. 3, Issue 1, January - February 2013, pp.1446-1450
2. Gunawan, T. S. (2017). Prototype Design of Smart Home System using Internet of Things. Indonesian Journal of Electrical and Computer Engineering (IJECE), Vol. 7, No. 1, pp. 107-115.
3. Fuchsia Research Corporation. (2014). Home Automation White Paper: A Brief Technology Overview of the Lighting Control Marketplace X-10, Insteon, Z-Wave, ZigBee, RadioRA2, Universal Powerline Bus (UPB).
4. Manohar, S., et al. (2015). International Journal of Computer Science and Mobile Computing, Vol.4 Issue.7, pp. 78-87.
5. Gunawan, T. S. (2018). Performance Evaluation of Smart Home System using Internet of Things. International Journal of Electrical and Computer Engineering (IJECE), Vol. 8, No. 1, pp. 400-411.
6. Wikipedia (2009). Home Automation. Retrieved from http://en.wikipedia.org/wiki/Home_automation.
7. Atzori, L., Iera, A., & Morabito, G. (2010). The internet of things: A survey. Computer networks, vol. 54, no. 15, pp. 2787-2805.
8. Singh, N., Bharti, S. S., Singh, R., & Singh, D. K. (2014). Remotely controlled home automation system. Advances in Engineering and Technology Research (ICAETR) 2014 International Conference on., pp. 1-5.
9. Mandula, K., Parupalli, R., Murty, C. H. A. S., Magesh, E., & Lunagariya, R. (2015). Mobile based home automation using internet of things (iot). Control Instrumentation

Communication and Computational Technologies International Conference on., pp. 340-343.

10. Gaikwad, P. P., Gabhane, J. P., & Golait, S. S. (2015). A survey based on Smart Homes system using Internet-of-Things. Computation of Power, Energy Information and Commuincation (ICCPEIC), 2015 International Conference on, pp. 0330-0335.
11. Esp32-wroom-32_datasheet_en V24.
12. Maksuti, S. (2021). Automated and Secure Onboarding for Systems.
13. Singh, S. (2020). Home Automatic.
14. Cheng, R. (2014). How much is the internet of thing worth?
15. Dietrich, E. (2018). Introduction to Home Automation.
16. Soliman, M. (2017). Design and Implementation of a Real-time Smart HomeAutomation System.

APPENDIX

PIN LAYOUT

1 38

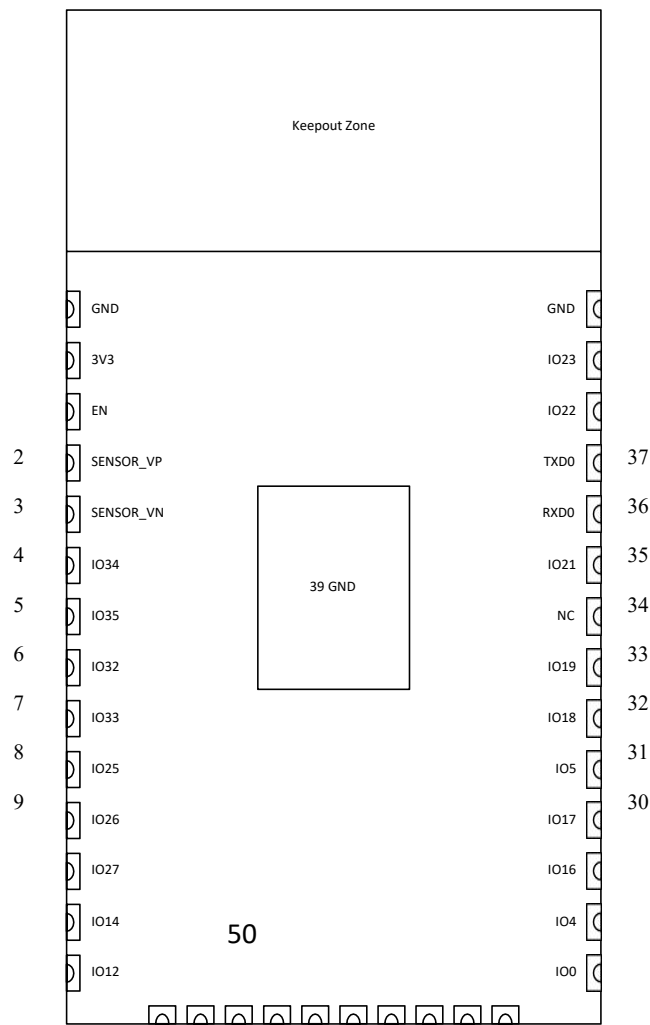

10 29
 11 28
 12 27
 13 26
 14 25

15 16 17 18 19 20 21 22 23 24

Name	No.	Type	Function
GND	1	P	Ground
3V3	2	P	Power supply
EN	3	I	Module-enable signal. Active high.
SENSOR_VP	4	I	GPIO36, ADC1_CH0, RTC_GPIO0
SENSOR_VN	5	I	GPIO39, ADC1_CH3, RTC_GPIO3
IO34	6	I	GPIO34, ADC1_CH6, RTC_GPIO4
IO35	7	I	GPIO35, ADC1_CH7, RTC_GPIO5
IO32	8	I/O	GPIO32, XTAL_32K_P (32.768 kHz crystal oscillator input), ADC1_CH4, TOUCH9, RTC_GPIO9
IO33	9	I/O	GPIO33, XTAL_32K_N (32.768kHz crystal oscillator output), ADC1_CH5, TOUCH8, RTC_GPIO8

IO25	10	I/O	GPIO25, DAC_1, ADC2_CH8, RTC_GPIO6, EMAC_RXD0
IO26	11	I/O	GPIO26, DAC_2, ADC2_CH9, RTC_GPIO7, EMAC_RXD1
IO27	12	I/O	GPIO27, ADC2_CH7, TOUCH7, RTC_GPIO17, EMAC_RX_DV
IO14	13	I/O	GPIO14, ADC2_CH6, TOUCH6, RTC_GPIO16, MTMS, HSPIC_LK, HS2_CLK, SD_CLK, EMAC_TXD2

IO12	14	I/O	GPIO12,ADC2_CH5,TOUCH5,RTC_GPIO15,MTDI,HSPIQ, HS2_DATA2, SD_DATA2, EMAC_TXD3
GND	15	P	Ground
IO13	16	I/O	GPIO13,ADC2_CH4,TOUCH4,RTC_GPIO14,MTCK,HSPID, HS2_DATA3, SD_DATA3, EMAC_RX_ER
SHD/SD2*	17	I/O	GPIO9, SD_DATA2, SPIHD, HS1_DATA2, U1RXD
SWP/SD3*	18	I/O	GPIO10, SD_DATA3, SPIWP, HS1_DATA3, U1TXD
SCS/CMD*	19	I/O	GPIO11, SD_CMD, SPICS0, HS1_CMD, U1RTS
SCK/CLK*	20	I/O	GPIO6, SD_CLK, SPICLK, HS1_CLK, U1CTS
SDO/SD0*	21	I/O	GPIO7, SD_DATA0, SPIQ, HS1_DATA0, U2RTS
SDI/SD1*	22	I/O	GPIO8, SD_DATA1, SPID, HS1_DATA1, U2CTS
IO15	23	I/O	GPIO15,ADC2_CH3,TOUCH3,MTDO,HSPICS0,RTC_GPIO 13,HS2_CMD, SD_CMD, EMAC_RXD3
IO2	24	I/O	GPIO2, ADC2_CH2, TOUCH2, RTC_GPIO12, HSPIWP, HS2_DATA0, SD_DATA0
IO0	25	I/O	GPIO0, ADC2_CH1, TOUCH1, RTC_GPIO11, CLK_OUT1, EMAC_TX_CLK
IO4	26	I/O	GPIO4, ADC2_CH0, TOUCH0, RTC_GPIO10, HSPIHD, HS2_DATA1, SD_DATA1, EMAC_TX_ER
IO16	27	I/O	GPIO16, HS1_DATA4, U2RXD, EMAC_CLK_OUT
IO17	28	I/O	GPIO17, HS1_DATA5, U2TXD, EMAC_CLK_OUT_180
IO5	29	I/O	GPIO5, VSPICS0, HS1_DATA6, EMAC_RX_CLK
IO18	30	I/O	GPIO18, VSPICLK, HS1_DATA7
IO19	31	I/O	GPIO19, VSPIQ, U0CTS, EMAC_TXD0
NC	32	-	-
IO21	33	I/O	GPIO21, VSPIHD, EMAC_TX_EN
RXD0	34	I/O	GPIO3, U0RXD, CLK_OUT2
TXD0	35	I/O	GPIO1, U0TXD, CLK_OUT3, EMAC_RXD2
IO22	36	I/O	GPIO22, VSPIWP, U0RTS, EMAC_TXD1
IO23	37	I/O	GPIO23, VSPID, HS1_STROBE
GND	38	P	Ground

CODE

```
// Fill-in information from your Blynk Template here

#define BLYNK_TEMPLATE_ID      "TMPLYnrRzPKp"

#define BLYNK_DEVICE_NAME     "Security System"

#define BLYNK_FIRMWARE_VERSION  "0.1.0"

#define BLYNK_PRINT Serial

// #define BLYNK_DEBUG

#define APP_DEBUG

// Uncomment your board, or configure a custom board in Settings.h

// #define USE_WROVER_BOARD

// #define USE_TTGO_T7
```

```
//#define USE_ESP32C3_DEV_MODULE

#define USE_ESP32S2_DEV_KIT

#define SwitchPin 17 //SD3

// define the GPIO connected with Relays and switches

#define RelayPin1 16 //D1

#define RelayPin2 22 //D2

#define RelayPin3 23 //D5

#define RelayPin4 27 //D6

#define RelayPin5 26 //D1

#define RelayPin6 25 //D1

//Change the virtual pins according the rooms

#define VPIN_BUTTON_1 V1

#define VPIN_BUTTON_2 V2

#define VPIN_BUTTON_3 V3

#define VPIN_BUTTON_4 V4

#define VPIN_BUTTON_5 V5

#define VPIN_BUTTON_6 V6

// Relay State

bool toggleState_1 = LOW; //Define integer to remember the toggle state for relay 1

bool toggleState_2 = LOW; //Define integer to remember the toggle state for relay 2
```

```
bool toggleState_3 = LOW; //Define integer to remember the toggle state for relay 3
bool toggleState_4 = LOW; //Define integer to remember the toggle state for relay 4
bool toggleState_5 = LOW; //Define integer to remember the toggle state for relay 5
bool toggleState_6 = LOW; //Define integer to remember the toggle state for relay 6
```

```
int num = 0;
```

```
int val = 0;
```

```
#include "BlynkEdgent.h"
```

```
BLYNK_CONNECTED() {
```

```
    // Request the latest state from the server
```

```
    Blynk.syncVirtual(VPIN_BUTTON_1);
```

```
    Blynk.syncVirtual(VPIN_BUTTON_2);
```

```
    Blynk.syncVirtual(VPIN_BUTTON_3);
```

```
    Blynk.syncVirtual(VPIN_BUTTON_4);
```

```
    Blynk.syncVirtual(VPIN_BUTTON_5);
```

```
    Blynk.syncVirtual(VPIN_BUTTON_6);
```

```
}
```

```
BLYNK_WRITE(VPIN_BUTTON_1) {
```

```
    toggleState_1 = param.asInt();
```

```
if(toggleState_1 == 1){  
    digitalWrite(RelayPin1, HIGH);  
    Serial.println("Working"); }  
else {  
    digitalWrite(RelayPin1, LOW);  
}  
}
```

```
BLYNK_WRITE(VPIN_BUTTON_2) {  
    toggleState_2 = param.asInt();  
    if(toggleState_2 == 1){  
        digitalWrite(RelayPin2, HIGH);  
        Serial.println("Working"); }  
    else {  
        digitalWrite(RelayPin2, LOW);  
    }  
}
```

```
BLYNK_WRITE(VPIN_BUTTON_3) {  
    toggleState_3 = param.asInt();  
    if(toggleState_3 == 1){  
        digitalWrite(RelayPin3, HIGH);  
        Serial.println("Working"); }  
    else {
```

```

    digitalWrite(RelayPin3, LOW);
}
}

BLYNK_WRITE(VPIN_BUTTON_4) {
    toggleState_4 = param.asInt();
    if(toggleState_4 == 1){
        digitalWrite(RelayPin4, HIGH);
        Serial.println("Working"); }
    else {
        digitalWrite(RelayPin4, LOW);
    }
}

BLYNK_WRITE(VPIN_BUTTON_5) {
    toggleState_5 = param.asInt();
    if(toggleState_5 == 1){
        digitalWrite(RelayPin5, HIGH);
        Serial.println("Working"); }
    else {
        digitalWrite(RelayPin5, LOW);
    }
}
}

```

```

BLYNK_WRITE(VPIN_BUTTON_6) {
  toggleState_6 = param.asInt();
  if(toggleState_6 == 1){
    digitalWrite(RelayPin6, HIGH);
    Serial.println("Working"); }
  else {
    digitalWrite(RelayPin6, LOW);
  }
}

void setup()
{
  Serial.begin(115200);
  delay(100);

  pinMode(RelayPin1, OUTPUT);
  pinMode(RelayPin2, OUTPUT);
  pinMode(RelayPin3, OUTPUT);
  pinMode(RelayPin4, OUTPUT);
  pinMode(RelayPin5, OUTPUT);
  pinMode(RelayPin6, OUTPUT);

  //pinMode(wifiLed, OUTPUT);
  pinMode(SwitchPin, INPUT_PULLUP);
}

```

```
//During Starting all Relays should TURN OFF

digitalWrite(RelayPin1, LOW);

digitalWrite(RelayPin2, LOW);

digitalWrite(RelayPin3, LOW);

digitalWrite(RelayPin4, LOW);

digitalWrite(RelayPin5, LOW);

digitalWrite(RelayPin6, LOW);

digitalWrite(SwitchPin, HIGH);

BlynkEdgent.begin();

Blynk.virtualWrite(VPIN_BUTTON_1, toggleState_1);

Blynk.virtualWrite(VPIN_BUTTON_2, toggleState_2);

Blynk.virtualWrite(VPIN_BUTTON_3, toggleState_3);

Blynk.virtualWrite(VPIN_BUTTON_4, toggleState_4);

Blynk.virtualWrite(VPIN_BUTTON_5, toggleState_5);

Blynk.virtualWrite(VPIN_BUTTON_6, toggleState_6);

}

void loop() {

BlynkEdgent.run();
```

```

val = digitalRead(SwitchPin);

if(val == 0 && num == 0){

    digitalWrite(RelayPin1, HIGH);

digitalWrite(RelayPin2, HIGH);

digitalWrite(RelayPin3, HIGH);

digitalWrite(RelayPin4, HIGH);

digitalWrite(RelayPin5, HIGH);

digitalWrite(RelayPin6, HIGH);

    num = 2;    }

else if (val == 1 && num == 2){

digitalWrite(RelayPin1, LOW);

digitalWrite(RelayPin2, LOW);

digitalWrite(RelayPin3, LOW);

digitalWrite(RelayPin4, LOW);

digitalWrite(RelayPin5, LOW);

digitalWrite(RelayPin6, LOW);

    num = 0;

    }

}

```