

**Design and Fabrication of a Simple and Affordable Vacuum Cleaner from
Locally Available Materials**

By

OLOYA OGHENEMARHO DIVINE - ENG1805325

AKPEH STEPHEN OSHOMA - ENG1805352

ESIEBOMA OGAGAOGHENE STEVENSON - ENG1805382

OSAKWE DANIEL EBUBE - ENG1805442

OMOROGHOMWAN PROSPER EGHENAYAGOSA - ENG1905645

**A Project Report submitted to the Department of Mechanical Engineering, in partial
fulfillment of the requirement for the award of the
Bachelors of Engineering Degree (B. Eng.) in Mechanical Engineering of the University
of Benin**

Department of Mechanical Engineering

University of Benin

Benin City

2022/2023

CERTIFICATION

This is to certify that this research work on the “Design and Fabrication of a Simple and Affordable Vacuum Cleaner from Locally Available Materials” was carried out by

OLOYA OGHENEMARHO DIVINE - ENG1805325

AKPEH STEPHEN OSHOMA - ENG1805352

ESIEBOMA OGAGAOGHENE STEVENSON - ENG1805382

OSAKWE DANIEL EBUBE - ENG1805442

OMOROGHOMWAN PROSPER EGHENAYAGOSA - ENG1905645

Of the Department of Mechanical Engineering, University of Benin, Benin City.

Engr. A. A. Ugherughe

Date

Supervisor

Dr. I. B. Owunna

Date

PG Coordinator

Prof. G. E. Sadjere

Date

Head of Department

DEDICATION

To God, Almighty and to our family and friends, the foundation of our strength and the embodiment of unwavering support, this report is dedicated to you. Your love, encouragement, and sacrifices have been the wind beneath my wings, propelling me forward in pursuit of my dreams. Your unwavering faith in us has been a source of inspiration, reminding us that no challenge is too great to overcome.

ACKNOWLEDGEMENTS

With profound humility and gratitude, we extend our sincerest acknowledgment to the myriad of individuals whose unwavering dedication and expertise have propelled the fruition of this report. Without their invaluable support, guidance, and motivation, this undertaking would have undoubtedly posed insurmountable hurdles.

Our heartfelt appreciation goes to our esteemed supervisor, Engineer A. A. Ugherughe, and the diligent coordination of Dr. I. B. Owunna, alongside the esteemed members of the faculty and department whose mentorship has left an indelible mark on our journey.

We are deeply indebted to each contributor for their invaluable contributions, which have significantly enriched the outcome of this endeavor.

ABSTRACT

The cleaning of living and work spaces are a fundamental human activity. Cleaning must be done for safety and human health. The process of cleaning can be cumbersome, tasking on the human muscle and time consuming when done in the traditional way of using brooms, brushes and similar tools. Modern living and work requirements demands that cleaning must be done fast and more efficiently. This need therefore demands that the cleaning of living and work spaces has to be mechanized to take away the burden from human muscles, improve efficiency, save time and cost. One way of achieving this is through the use of Vacuum Cleaners.

A literature review during the course of this project work revealed that virtually all available Vacuum Cleaners listed and reviewed online as well as those found in shops here in Nigeria are highly technologically sophisticated and unaffordable for homes and small scale firms. The need therefore arises for the production of a locally affordable Vacuum Cleaner made from readily available local materials. The literature review and search identified a simple handheld Vacuum Cleaner that can be modified and adapted through a redesign to use locally available materials for its production. Several concept designs were proposed and the most acceptable in terms of simplicity, availability of local materials and affordability was chosen.

The components for the chosen design were redesigned one by one with the idea of local production in mind. These includes the intake Wand and its dust agitator, the housing, the motor and its mounting within the housing, the air stream expansion section of the housing, the dust bag and its attachment to the housing and finally air flow exhaust area. After the design of these components the material needed for their fabrication were procured and the components fabricated. These fabricated components were then assembled to produce the portable Vacuum Cleaner complete with a shoulder hanging belt.

The assembled unit was then tested in the 500 level classroom. The performance of the Vacuum Cleaner was found to be really effective in dust pickup through the dust agitator at the end of the end of the wand that is always pressed against the floor as it is pushed back and forth during the cleaning process. No dust particle size in the classroom was left on the floor during the testing. It is worthy of

note that there was a small amount of very very fine particles of dust noticed in the effluent exhaust air. The possible reasons suggested for this unwanted occurrence by our project group were listed as

1. A larger than required dust bag particle size retention holes that allowed these very fine dust particles to escape with the exhaust air.

and or

2. Insufficient expansion of the exhaust air to reduce its speed to allow these very fine particles to deposit in the air stream expansion zone of the Vacuum Cleaner housing.

For the fact that the fabricated Vacuum Cleaner was able to pick up virtually all particles on the floor, this project is therefore considered a great success. It is hoped that improvements to this design would continue to be carried out in future project work until it reaches the perfection in both aesthetics and performance for commercialization.

TABLE OF CONTENTS

Certification	i
Dedication	ii
Acknowledgements	iii
Abstract	iv
Table of Contents	vi
List of Figures	ix
List of Tables	xii
Frequently Used Symbols, Labels and Terms	xiii
CHAPTER ONE	1
INTRODUCTION	1
1.1 Background to the Study	1
1.2 Statement of the Problem	2
1.3 Aim and Objective of the Study	2
1.3.1 Aim	2
1.3.2 Objectives	3
1.4 Scope of Work	3
1.5 Significance of the Study	3
1.6 Methodology	4
CHAPTER TWO	5
LITERATURE REVIEW	5
2.1 Vacuum Cleaners	5

2.2	Types of Vacuum Cleaners	9
2.2.1	Upright Vacuum Cleaners	10
2.2.2	Cylinder Vacuum Cleaners	11
2.2.3	Drum Vacuum Cleaners	12
2.2.4	Pneumatic Vacuum Cleaners	14
2.2.5	Backpack Vacuum Cleaners	14
2.2.6	Hand-held Vacuum Cleaners	15
2.2.7	Robotic Vacuum Cleaners	16
2.3	Parts and Major Components of Vacuum Cleaners	18
2.4	Major Problems Associated with Vacuum Cleaners	22
2.4.1	General Challenges	22
2.4.2	Vacuum Cleaner Challenges in Nigeria	24
CHAPTER THREE		26
MATERIALS AND METHODS		26
3.1	Design Consideration	26
3.1.1	Determine the Area of Application of the proposed Vacuum Cleaner.	28
3.1.2	Determine the Dust Particle Type and Size to be dealt with by the Vacuum Cleaner.	28
3.1.3	Determine the Size of the proposed Vacuum Cleaner	29
3.1.4	Determine the Source of Power for the proposed Vacuum Cleaner	30
3.1.5	Selection of Vacuum Cleaners options from the Literature Review that match the criteria determined from 1 – 3 above	30
3.1.6	Design of the Components of the proposed Vacuum Cleaner	31
3.1.6.1	Conceptual Design	31
3.1.6.2	Design	34
3.2	Morphological Chart	46
3.3	Fabrication Process	46
3.3.1	Tools Used for Fabrication	47

3.3.2	Challenges Encountered During Fabrication and Solutions	48
3.4	Optimization of the Vacuum Cleaner	48
3.5	Vacuum Cleaner Views	51
3.6	Specification	55
CHAPTER FOUR		58
RESULT		58
4.1	Testing and Performance Evaluation	58
4.1.1	Performance Evaluation Criteria	58
4.1.2	Testing Methods	59
4.1.3	Results and Discussion	59
4.2	Bill of Engineering Measurement and Evaluation (BEME)	60
4.3	Comparative Analysis of this Locally Available Materials VS Standard Vacuum Cleaners	62
4.4	SWOT Analysis of the Vacuum Cleaner Fabricated from Locally Available Materials	64
4.4.1	Strengths	64
4.4.2	Weaknesses	64
4.4.3	Opportunities	65
4.4.4	Threats	65
4.5	Design Analysis and Recommendations	65
CHAPTER FIVE		67
CONCLUSION AND RECOMMENDATIONS		67
5.1	Summary of Key Findings	67
5.2	Recommendations for Future Studies or Improvements	67
5.3	Conclusion	67
CHAPTER SIX		69
REFERENCES.		69

LIST OF FIGURES

Figure 2.1 - Vacuum Cleaner	5
Figure 2.2 - Vacuum Cleaner Diagram	6
Figure 2.3 Daniel Hess's Carpet Sweeper.....	7
Figure 2.4 - Upright Vacuum Cleaner.....	10
Figure 2.5 - Canister Vacuum Cleaner.....	12
Figure 2.6 - Drum Vacuum Cleaner.....	13
Figure 2.7 - Backpack Vacuum Cleaner	15
Figure 2.8 - Handheld Vacuum Cleaner.....	16
Figure 2.9 - Robotic Vacuum Cleaner	17
Figure 2.10 - Internal Drawing of a Handheld Vacuum Cleaner.....	18
Figure 2.11- Components of a Vacuum Cleaner.....	18
Figure 2.12 - Vacuum Cleaner Motor	19
Figure 2.13 - Vacuum Cleaner Fan	19
Figure 2.14 - Vacuum Cleaner Filter	20
Figure 2.15 - Vacuum Cleaner Dust Collection Bag	20
Figure 2.16 - Vacuum Cleaner Hose.....	21
Figure 2.17 - Vacuum Cleaner Wand.....	21
Figure 2.18 - Vacuum Cleaner Brushes	21

Figure 2.19 - Vacuum Cleaner Components & Accessories.....	22
Figure 3.1 – Size analysis of dirt particles found in a household.....	29
Figure 3.2 – Diagram of design concept one	31
Figure 3.3 – Diagram of design concept two	32
Figure 3.4 – Diagram of design concept three	33
Figure 3.5 – AC Motor from old blower	38
Figure 3.6 – Agitator Mechanism	38
Figure 3.7 – Rigid 0.5 inch PVC pipe for wand.....	39
Figure 3.8 – 6 to 4 Inches reducer	40
Figure 3.9 – 4 to 2 Inches reducer	40
Figure 3.10 – Flexible hose	41
Figure 3.11 – Nylon filter.....	41
Figure 3.12 – Locally available Fan blades.....	42
Figure 3.13 – Fan blades considered for the design	42
Figure 3.14 – Exhaust Side of the vacuum Cleaner	43
Figure 3.15 – 6 inches Pipe housing	44
Figure 3.16 – Strap for easier unit mobility	45
Figure 3.17 – Broken Plastic Fan blade from stress failure	50
Figure 3.18 – Orthographic view of the Wand.....	51
Figure 3.19 – Orthographic view of Pipe Housing	51

Figure 3.20 – Orthographic view of Agitator Mechanism.....	52
Figure 3.21 – Plan View of Blade	52
Figure 3.22 – Orthographic view of 6 to 4 Inches Pipe reduction Joint	53
Figure 3.23 – Orthographic view of 4 to 2 Inches Pipe reduction Joint	54
Figure 3.24 – Orthographic view of Exhaust Cover	55
Figure 3.25 – View of the Vacuum Cleaner assembly.....	55
Figure 3.26 – Picture of the Vacuum Cleaner in Design Stage.....	56
Figure 3.27 – Diagram of the Vacuum cleaner design.....	57

LIST OF TABLES

<u>Table 3.1 – Decision matrix used to rank developed conceptual design</u>	33
<u>Table 3.2 – Vacuum cleaner components and locally available material used</u>	46
<u>Table 3.3 – Morphological Chart</u>	46
<u>Table 3.4 – Tools used for fabrication</u>	47
<u>Table 4.1 - Performance Evaluation Criteria</u>	60
<u>Table 4.2 – Bill of Materials</u>	62
<u>Table 4.3- Materials Comparative Analysis</u>	62
<u>Table 4.4- Performance Comparative Analysis</u>	63
<u>Table 4.5- Cost Comparative Analysis</u>	63
<u>Table 4.6- Results of detailed design</u>	66

FREQUENTLY USED SYMBOLS, LABELS AND TERMS

AC - Alternating Current

BEME - Bill of Engineering Measurement and Evaluation

BOM - Bill of Materials

CAD - Computer-Aided Design

DC - Direct Current

HEPA - High-Efficiency Particulate Air

PVC - Polyvinyl Chloride

CHAPTER ONE

INTRODUCTION

1.1 Background to the Study

Cleaning is a human activity that is essentially carried out every day in our lives. Cleaning happens in various forms. The human body is cleaned every day. Every area of one's environment and living space are also cleaned every day.

This project work is concerned with cleaning human living spaces. In human living space, different types of unwanted materials often get generated. These unwanted materials include:

1. Food or snacks wrapper
2. Dust brought into living space from outside including small particles/debris, and particles brought in by foot wares.
3. Parasitic animals that are found within the living space also do generate unwanted materials.

The focus of this work is on the solid forms of unwanted materials (not trying to purify air). These solid refuse or unwanted materials are often removed through the use of brushes, brooms and special needs brushes. Most of the materials that are often used on furniture surfaces and floors are often removed with brushes and brooms but this is often more cumbersome and manual such that elderly and frail people often find it difficult to carry out. Mechanical devices have been invented to assist such frail and elderly people with the task of cleaning. Apart from assisting the frail, these mechanical devices often does the job of cleaning more efficiently i.e. faster and accurately in less in less time as such even able bodied persons who do not have enough time but want efficient work done often use these devices for cleaning. The main device for cleaning these types of materials (waste) from the home or commercial spaces within buildings is the Vacuum cleaner. From their invention

vacuum cleaners have been sold on their ease of use and effectiveness (Harmer, L., et al., 2015).

Often the vacuum cleaners are manufactured abroad and imported into this country (Nigeria) using foreign exchange at a time like this in the country, any measures aimed at conserving our foreign exchange must be welcomed and this is why attempts to produce locally vacuum cleaners is a welcome idea and that is the purpose of this work.

1.2 Statement of the Problem

Currently, there is no Nigerian manufacturing company producing vacuum cleaners. This does not mean that vacuum cleaners are not being sold within the country. Most high value stores often stock vacuum cleaners of various designs. Vacuum cleaners vary in sizes depending on the area of applications. Some handheld vacuum cleaners are used within the car if the seats are made of fabric and the floors are rugged. We do realize that specialized equipment for manufacturing components of the vacuum cleaner is not readily available. The attempt in this project is to improvise with available materials to design and fabricate a fairly effective vacuum cleaner. As such, the problem to be solved by this project work is to design a vacuum cleaner that can be fabricated from locally available materials.

1.3 Aim and Objective of the Study

1.3.1 Aim

The aim of this project work is to design a vacuum cleaner that can be fabricated from locally available materials.

1.3.2 Objectives

- To produce a design of a vacuum cleaner
- To go around shops & places where required materials can be found and purchased
- To design the components based on the found materials
- To fabricate the component
- To assemble the components of the vacuum cleaner
- Test the vacuum cleaner

1.4 Scope of Work

The scope of work of this project is limited to:

1. To design a vacuum cleaner using locally available materials.
2. To fabricate the designed components
3. To assemble the vacuum cleaner from the fabricated components
4. To evaluate the performance and efficiency of the assembled unit by testing
5. To produce a cost analysis of the designed vacuum cleaner

1.5 Significance of the Study

This study is multi-faceted and holds importance at various levels:

1. To prove that affordable cleaning solutions can be developed using locally available materials
2. Sustainability: Being locally developed and fabricated, the use of this device can be extended in terms of its life span as it is possible to repair and maintain with locally available materials.
3. Local Economic Development: The use of locally sourced materials and the potential involvement of local craftsmen or workshops can stimulate economic development within the community by providing employment and saving foreign exchange.
4. Community Empowerment: Through this project, communities can become less reliant on external suppliers for everyday appliances. This empowerment not only increases self-sufficiency but also strengthens community cohesion and resilience.

1.6 Methodology

1. Research into types and designs of vacuum cleaners
2. Design of a locally produced vacuum cleaner by using CAD Modeling
3. Search the local market for materials that can be used to fabricate the design components
4. To procure the materials that can be used to fabricate the design components
5. To find tools machineries and workshops that can be used in the fabrication process
6. To fabricate
7. Assemble the vacuum cleaner components, taking care to follow the CAD
8. Testing and Performance Evaluation:
9. Produce a bill of quantity

CHAPTER TWO

LITERATURE REVIEW

The initial phase of this research involved an extensive review of existing literature to gain insights into vacuum cleaner designs and technologies. Relevant scientific journals, engineering publications, and patents were scrutinized to understand the key principles, innovations, and challenges associated with vacuum cleaner development. This literature review laid the foundation for our project, providing a comprehensive understanding of the state-of-the-art in vacuum cleaner design.

2.1 Vacuum Cleaners

The Oxford advanced learners dictionary defines a vacuum cleaner as “An electrical apparatus that by means of suction collects dust and small particles from floors and other surfaces”.



Figure 2.1 - Vacuum Cleaner

Generally, a vacuum cleaner can be defined as: “An electrically operated appliance that removes soiled material (dust, fiber, threads) from the surface to be cleaned by airflow created

by a vacuum developed within the unit by an electrically powered vacuum generator or fan. The material thus removed is separated and stored in the appliance and the cleaned suction air is returned to the ambient”. Vacuum cleaners exist in a variety of sizes, shapes and models for domestic and commercial use and for different applications (AEA Energy and Environment, 2009).

A vacuum cleaner is an electromechanical appliance commonly used for cleaning floors, furniture, rugs and carpets by suction (Kapila, V., 2012). An electric motor inside the appliance turns a fan which creates a partial vacuum and causes outside air to rush into the evacuated space (Eidmohammadi, N., 2014). This forces any dirt or dust near the nozzle into a bag inside the machine or attached to the outside. The garbage and dust will be collected in the dust bag and the clean air will be discharged outside through the filter (Yu X.W., 2001).

Vacuum cleaners are ubiquitous household and industrial appliances designed to efficiently remove dirt, dust, debris, and particulates from various surfaces, such as floors, carpets, upholstery, and more. They rely on suction power to create a low-pressure environment that pulls in and traps particles, leaving the cleaned area free from contaminants. Vacuum cleaners offer a convenient and hygienic method for maintaining cleanliness.



Figure 2.2 - Vacuum Cleaner Diagram

The Evolution of the Vacuum Cleaner

In 1860, Daniel Hess, hailing from West Union, Iowa, introduced a remarkable cleaning device, initially termed a "carpet sweeper" rather than a vacuum cleaner. This innovative machine featured a rotating brush, reminiscent of traditional carpet sweepers, and a sophisticated bellows mechanism atop its body, which effectively generated suction to remove dust and dirt. On July 10, 1860, Hess secured a patent (US No. 29,077) for his pioneering vacuum cleaner.



Figure 2.3 Daniel Hess's Carpet Sweeper

The first manually powered cleaner utilizing vacuum principles emerged as the "Whirlwind" in 1868, invented by Ives W. McGaffey in Chicago. This compact machine, however, presented a challenge to users who needed to simultaneously turn a hand crank while pushing it across the floor. McGaffey partnered with The American Carpet Cleaning Co. of Boston to market it to the public, with a price tag of \$25. The Whirlwind's success is somewhat shrouded in history, as most were sold in Chicago and Boston, and many may have been lost in the Great Chicago Fire of 1871. Only two known Whirlwinds have survived, one of which

is housed in the Hoover Historical Center. McGaffey secured a patent (US No. 91,145) on June 8, 1869, for his invention.

In 1876, Melville R. Bissell of Grand Rapids, Michigan, designed a hand-powered carpet sweeper to help his wife, Anna Sutherland Bissell, tackle sawdust on their carpets. This endeavor led to the birth of Bissell Carpet Sweepers. After Melville's unexpected passing in 1889, Anna assumed control of the company, becoming a prominent businesswoman of her time. The company expanded its range of cleaning tools to include portable vacuum cleaners.

On November 14, 1898, John S. Thurman, from St. Louis, Missouri, filed a patent (US No. 634,042) for a "pneumatic carpet renovator," which was subsequently issued on October 3, 1899. Thurman created a gasoline-powered carpet cleaner for the General Compressed Air Company. In a St. Louis Dispatch newspaper advertisement, Thurman introduced a motorized cleaning system that went door-to-door in St. Louis, offering cleaning services at \$4 per visit. By 1906, Thurman was offering built-in central cleaning systems that utilized compressed air but lacked dust collection. Although Thurman's machine is sometimes considered the first vacuum cleaner, it notably blew dust into a receptacle rather than sucking it in.

The Hoover Company introduced the first commercially successful upright vacuum cleaner in the 1920s. The design featured a motorized brush roll and a cloth filter bag. This innovation made vacuuming more efficient and practical for households.

In the 1930s, manufacturers began producing canister-style vacuum cleaners. These designs featured a separate motor and dust collection unit connected by a hose. Canister vacuums offered increased maneuverability and a variety of attachments for different surfaces.

In the 1980s, James Dyson revolutionized the vacuum cleaner industry by introducing bagless technology. His vacuum cleaners used cyclonic separation to trap dirt and dust without the need for disposable bags. This innovation reduced maintenance costs and improved suction efficiency.

The 21st century saw the rise of robotic vacuum cleaners. The Roomba, introduced by iRobot in 2002, popularized the concept of autonomous vacuuming. These devices use sensors and artificial intelligence to navigate and clean floors without direct human intervention.

In 2004, a British company unveiled the Airider, a floating vacuum cleaner that glides on a cushion of air. It claimed to be lightweight and easier to maneuver, even though the Hoover Constellation had employed a similar concept at least 35 years earlier.

Modern vacuum cleaners often come equipped with smart features and connectivity. Users can control and schedule cleaning sessions using smartphone apps. Some models incorporate sensors to map and navigate spaces intelligently.

The evolution of vacuum cleaners demonstrates the symbiotic relationship between mechanical engineering and innovation. Through the application of engineering principles and the pursuit of novel ideas, the task of cleaning has been made more efficient, accessible, and technologically integrated.

2.2 Types of Vacuum Cleaners

Vacuum cleaners come in a variety of types and designs, each catering to specific cleaning needs and preferences. There are various types of Vacuum Cleaners such as Upright Vacuum Cleaners, Stick Vacuum Cleaners and Hand-held Vacuum Cleaners. And all these Vacuum Cleaners generally use Electrical Energy as a source of Power (Hossain, M.S., et al., 2023). Understanding the merits and demerits of each design helps users choose the most suitable option.

2.2.1 Upright Vacuum Cleaners

Upright vacuum cleaners, prevalent in the United States, Britain, and several Commonwealth nations, stand out as an unusual sight in Continental Europe. Their design consists of a cleaning head with an attached handle and bag. Upright models typically employ a rotating brush roll or beater bar, effectively eliminating dirt through a blend of sweeping and vibration. There are two primary types of upright vacuums: dirty-air/direct fan (commonly found in commercial vacuums) and clean-air/fan-bypass (featured in most modern domestic vacuums).

The older direct-fan design incorporates a large impeller (fan) located near the suction opening, allowing dirt to pass directly before being directed into a bag. A separate cooling fan often keeps the motor cool. Due to their large-bladed fans and short air paths, direct-fan cleaners produce highly efficient airflow with minimal power, making them excellent for carpet cleaning. However, their efficiency decreases for above-floor cleaning, as the airflow weakens when passing through a long hose, optimized primarily for volume rather than suction.



Figure 2.4 - Upright Vacuum Cleaner

Merits:

- **Effective on Carpets:** Upright vacuum cleaners are excellent for deep cleaning carpets due to their rotating brush rolls.
- **Ease of Use:** They are easy to maneuver and don't require bending down to use.
- **Compact Design:** Typically, they have a compact design for storage.

Demerits:

- **Not Ideal for Tight Spaces:** Upright models can be less effective in tight spots or under furniture.
- **Limited Versatility:** They may not be as versatile for above-floor cleaning compared to other types.

2.2.2 Cylinder Vacuum Cleaners

Cylinder models are often referred to as canister models in the United States. They are very popular in European homes. They feature a separate unit housing the motor and dust collector (using a bag or bag-less system) mounted on wheels. This unit connects to the vacuum head through a flexible hose, offering remarkable flexibility and maneuverability. Cylinder models can easily reach under furniture and excel at vacuuming stairs and vertical surfaces. Many cylinder models come with power heads, which function similarly to mechanical beaters in upright units, ensuring their efficiency on carpets.



Figure 2.5 - Canister Vacuum Cleaner

Merits:

- **Versatility:** Cylinder vacuums are highly versatile, suitable for various cleaning tasks, including above-floor surfaces.
- **Maneuverability:** Their flexible hoses make them easy to maneuver and reach under furniture.
- **Power Heads:** Many models come with power heads for efficient carpet cleaning.

Demerits:

- **Bulkier Setup:** The separate unit for the motor and dust collector can be less compact.
- **Tangles in Hoses:** Hoses can sometimes tangle or kink, affecting the cleaning process.

2.2.3 Drum Vacuum Cleaners

Drum or shop vacuum models serve as heavy-duty industrial counterparts to cylinder vacuum cleaners. These machines feature a large, vertically positioned drum, which can be stationary

or equipped with wheels. Smaller versions are electrically powered and suitable for garages or small workshops. Larger models, capable of storing over 200 liters, often connect to compressed air, employing the Venturi effect to create a partial vacuum.



Figure 2.6 - Drum Vacuum Cleaner

Merits:

- Heavy-Duty: These models are built for heavy-duty industrial use and can handle substantial debris.
- Large Capacity: Larger drum models can store a significant amount of dirt and debris.
- Compressed Air Option: Some models use compressed air for powerful suction.

Demerits:

- Size: They are often large and may not be practical for household use.
- Limited Home Applicability: Not ideal for typical home cleaning needs.

2.2.4 Pneumatic Vacuum Cleaners

Pneumatic or pneumatic wet/dry vacuum cleaners are tailored for industrial settings and connect to compressed air. These models efficiently handle both wet and dry debris, making them invaluable in industrial plants and manufacturing facilities.

Merits:

- **Industrial Use:** Suited for industrial settings, where compressed air is readily available.
- **Effective on Multiple Soilage Types:** Can handle both wet and dry debris, making them versatile in such environments.

Demerits:

- **Limited Household Use:** Not practical for regular household cleaning.
- **Reliance on Compressed Air:** Requires access to compressed air, limiting portability.

2.2.5 Backpack Vacuum Cleaners

Backpack vacuum cleaners are the go-to choice for commercial cleaning, enabling users to navigate large areas with ease. Essentially, they resemble cylinder vacuum cleaners strapped onto the user's back.



Figure 2.7 - Backpack Vacuum Cleaner

Merits:

- Commercial Use: Ideal for commercial cleaning, allowing users to cover large areas quickly.
- Backpack Design: The design makes them easy to carry and maneuver.
- Even Weight Distribution: Weight is distributed across the back, reducing fatigue.

Demerits:

- Not Ideal for Home Use: Not typically designed for home cleaning.
- May Require Training: Proper use of backpack vacuums may require training.

2.2.6 Hand-held Vacuum Cleaners

Lightweight hand-held vacuum cleaners, powered either by rechargeable batteries or mains electricity, are popular for handling smaller spills. Notable examples include the Black & Decker DustBuster, which made its debut in 1979, and various hand-held models from Dirt Devil, introduced in 1984. Some battery-powered handheld vacuums are wet/dry rated,

requiring partial disassembly and cleaning after picking up wet materials to prevent unpleasant odors.

Merits:

- **Portability:** Extremely portable and convenient for quick cleanups.
- **Battery-Powered Options:** Battery-powered models offer flexibility without cords.
- **Lightweight:** Easy to handle for small spills and spot cleaning.



Figure 2.8 - Handheld Vacuum Cleaner

Demerits:

- **Limited Capacity:** Limited storage capacity, suitable only for small messes.
- **Short Battery Life:** Battery-powered models may have a limited runtime.

2.2.7 Robotic Vacuum Cleaners

In the early 1990s, several companies introduced robotic vacuum cleaners, which resemble carpet sweepers with limited suction power. Brands like Roomba, Robomaxx, Intellibot,

Trilobite, FloorBot, and Dyson created these autonomous machines, which navigate a floor in a mostly chaotic pattern, collecting surface dust debris into a dustbin. They can maneuver around furniture, return to a docking station to recharge, and some are even capable of emptying their dust containers at the dock.

Merits:

- **Autonomous Operation:** These vacuums can operate autonomously and clean while you're away.
- **Convenience:** They save time and effort with minimal manual intervention.
- **Navigation:** Many models can navigate around furniture and obstacles.

Demerits:

- **Limited Suction Power:** Typically have limited suction power for deep cleaning.
- **Random Patterns:** Clean in somewhat random patterns, which may miss spots.
- **Initial Cost:** Can be expensive compared to traditional vacuum cleaners.



Figure 2.9 - Robotic Vacuum Cleaner

The choice of vacuum cleaner design should align with the specific cleaning requirements and preferences of the user. Consider the types of surfaces to be cleaned, the layout of the space, and the desired level of automation when selecting the most suitable vacuum cleaner for the job.

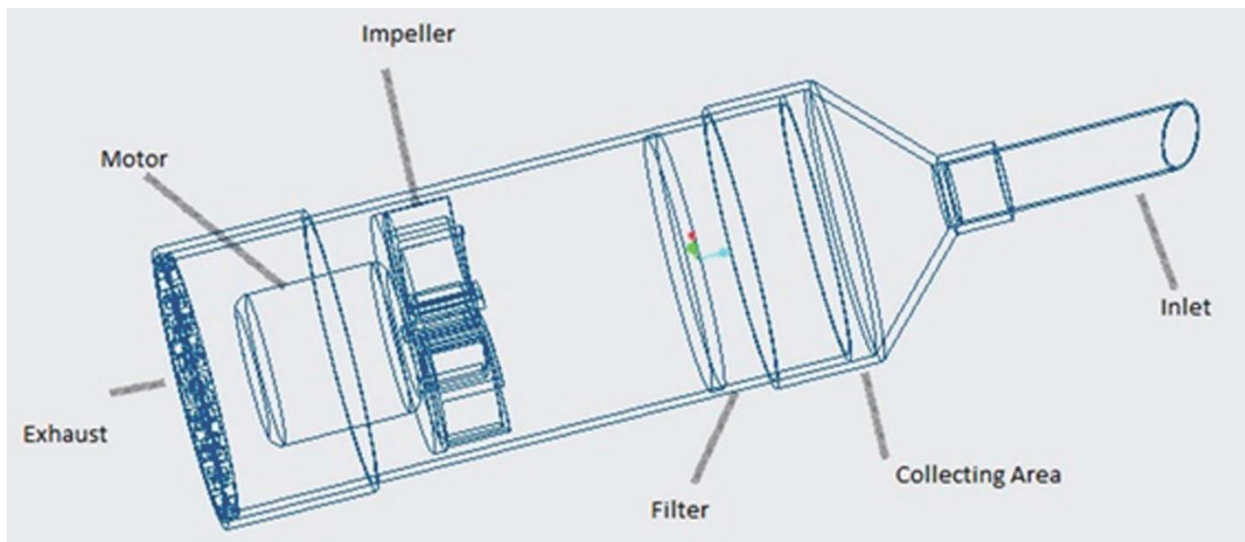

Figure 2.10 - Internal Drawing of a Handheld Vacuum Cleaner

2.3 Parts and Major Components of Vacuum Cleaners

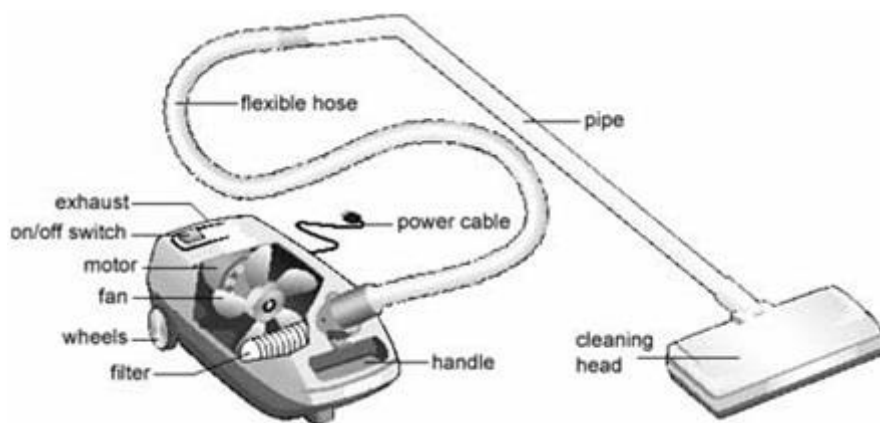

Figure 2.11- Components of a Vacuum Cleaner

1. Motor: The motor serves as the heart of a vacuum cleaner. It generates the necessary suction power by creating a flow of air. Vacuum cleaners can feature different types of

motors, including electric motors for most household models and manual hand-operated mechanisms for non-electric or manual models.

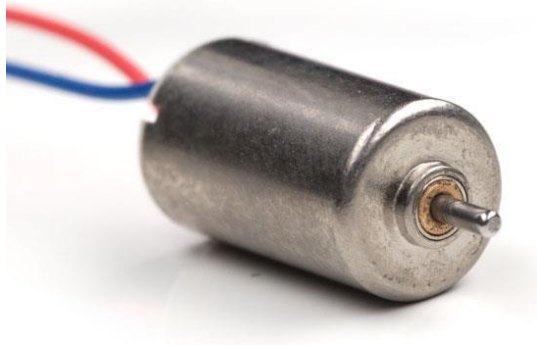

Figure 2.12 - Vacuum Cleaner Motor

2. Suction System: The suction system is responsible for creating the airflow necessary to capture dirt and debris. It typically consists of a fan, impeller, or other mechanisms that draw air into the vacuum cleaner. The suction power is a crucial factor in a vacuum cleaner's efficiency.

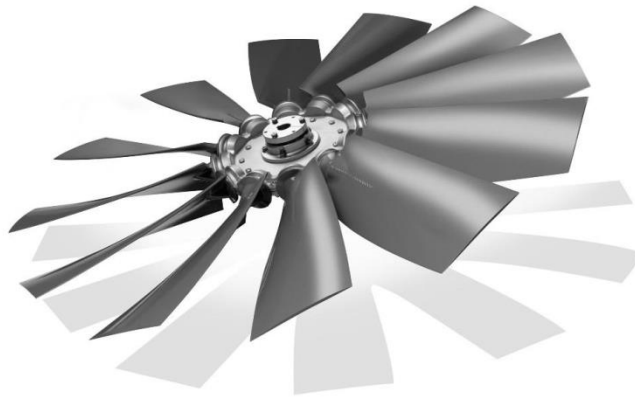

Figure 2.13 - Vacuum Cleaner Fan

3. Filters: Filters play a vital role in ensuring that the air expelled from the vacuum cleaner is clean and free from contaminants. Common filter types include high-efficiency particulate air (HEPA) filters, foam filters, and cloth filters. Filters capture dust and allergens, preventing them from re-entering the environment.



Figure 2.14 - Vacuum Cleaner Filter

4. Dust Collection Container or Bag: Vacuum cleaners use either a dust collection container or a disposable bag to store the collected dirt and debris. Bagged models require regular replacement of bags, while bag-less models allow for easier emptying and cleaning of the container.



Figure 2.15 - Vacuum Cleaner Dust Collection Bag

5. Hose and Nozzle: The hose and nozzle are essential components for directing the suction to specific areas. Nozzles come in various shapes and sizes, designed for different surface types. Some vacuum cleaners have adjustable nozzles to accommodate a variety of cleaning tasks.



Figure 2.16 - Vacuum Cleaner Hose

6. Wand or Extension Tubes: Wands or extension tubes allow users to reach higher or more distant areas. They can be attached to the hose to extend the cleaner's reach and accessibility.



Figure 2.17 - Vacuum Cleaner Wand

7. Brushes and Agitators: Vacuum cleaners often incorporate brushes or agitators to dislodge dirt and debris from carpets and upholstery. These components help loosen particles, making it easier for the suction system to capture them.



Figure 2.18 - Vacuum Cleaner Brushes

8. Power Control and Settings: Many vacuum cleaners offer adjustable power settings, allowing users to customize the suction intensity based on the type of surface being cleaned. This feature enhances versatility and efficiency.

9. Cord or Battery: Electric vacuum cleaners are equipped with power cords that connect to electrical outlets. Cordless models use rechargeable batteries for portability. The power source provides energy to the motor and other components.

10. Body and Housing: The body and housing of a vacuum cleaner encase all the internal components. They are designed for durability and ease of maneuverability. The choice of materials and design can impact the overall weight and sturdiness of the appliance.



Figure 2.19 - Vacuum Cleaner Components & Accessories

2.4 Major Problems Associated with Vacuum Cleaners

2.4.1 General Challenges

Vacuum cleaners have become indispensable tools in households worldwide in developed countries, revolutionizing the way they maintain cleanliness and hygiene in their living

spaces. However, like any technological innovation, they are not immune to challenges. There are some of the major problems associated with vacuum cleaners.

1. Lack of Standardization

One significant challenge in the realm of vacuum cleaners is the lack of standardized specifications and features across different models and brands. This can lead to confusion for consumers, making it difficult to compare and choose the most suitable vacuum cleaner for their needs.

2. Durability Issues

Some vacuum cleaners are prone to durability issues, with components such as motors, filters, and brushes wearing out over time. This can result in decreased performance and efficiency, leading users to incur additional maintenance costs or, in extreme cases, necessitating the purchase of a new unit.

3. Noise Pollution

Another common concern associated with vacuum cleaners is the noise they generate during operation. As is well known, the vacuum cleaner usually causes the noise pollution to the quiet and comfortable family environment, which is the main drawback of it. (Wang, W., et al., 2012).

4. Environmental Impact

The environmental impact of vacuum cleaners is a growing concern. Many traditional vacuum cleaners use non-biodegradable bags and filters, contributing to environmental pollution. Additionally, the energy consumption of some models raises questions about their overall carbon footprint.

2.4.2 Vacuum Cleaner Challenges in Nigeria

The challenges mentioned above are general, there are certain issues associated with vacuum cleaners in third world countries like Nigeria.

1. Power Supply Instability

One of the primary challenges in Nigeria is the instability of the power supply. Frequent power outages and fluctuations can affect the performance/usage of vacuum cleaners, leading to damage or reduced efficiency. Users need to invest in additional constant powers supply and power protection devices to mitigate these issues.

2. Dust and Debris Composition

Nigeria, like many other African countries, faces unique environmental challenges, including a higher prevalence of dust and debris with specific compositions. Some foreign vacuum cleaners may struggle to effectively handle these conditions, requiring more frequent maintenance and replacement of filters.

3. Limited Access to Maintenance Services

In Nigeria, access to specialized maintenance services for vacuum cleaners is limited. This poses a significant challenge for users who rely on these devices for daily cleaning, as they will struggle to find timely and affordable repairs.

4. Affordability and Accessibility

The economic landscape in Nigeria affects the affordability and accessibility of quality vacuum cleaners. High-quality models with advanced features are out of reach for a significant portion of the population, limiting their ability to benefit from the vacuum cleaner technology.

CHAPTER THREE

MATERIALS AND METHODS

3.1 Design Consideration

Vacuum Cleaners come in various types and applications. It therefore follows that the design and fabrication of any particular type of Vacuum Cleaner would differ based on these characterizations. Generally, a guideline can be established which could be followed in order to produce any type of Vacuum Cleaner. These guidelines could therefore form the basis for the methodology to be followed in producing one. These could be as follows.

1. Determine the Area of Application of the proposed Vacuum Cleaner:
 - a) Industrial, Commercial or Domestic Use.
 - b) Indoors or Outdoor Use.
 - c) Compact Spaces, Medium Size Enclosures or Open and Wide Spaces.
 - d) Floors, Furniture Fabrics or Inside Equipment and Machineries.
2. Determine the Dust Particle Type and Size to be dealt with by the Vacuum Cleaner.
3. Determine the Size of the proposed Vacuum Cleaner:
 - a) Volume of the unit based on its motor size and dust holding capacity required.
 - b) Method of mobility – dragged on surfaces, on rollers, hand held or a hoisted backpack.
 - c) Portability – How and when does it have to move?
4. Determine the Source of Power for the proposed Vacuum Cleaner

a) DC (Battery) Power Drive/Motor

b) AC Power Drive/Motor

5. Selection of Vacuum Cleaners options from the Literature Review that match the criteria determined from 1 – 3 above.

6. Design of the Components of the proposed Vacuum Cleaner.

7. Figure 2.10 and 2.11 shows the typical components of the two broad categories of Vacuum Cleaners – the Standard and the Handheld Vacuum Cleaner. The point to note is that the Standard Vacuum Cleaner has all the standard or what can be referred to as the basic components of a Vacuum Cleaner while the handheld type has some components made irrelevant and as such have fewer components.

8. Since the design process would only engage the design of the relevant components for the chosen type of Vacuum Cleaner sought it would be necessary to list all the basic components and through the process of type and category eliminate those components that are irrelevant.

a) Air Jet Speed Design for Dust Particle Type and Size Pickup.

b) Dust Particle Type and Size Agitation Mechanism Design.

c) Air Stream Conveyor Rigid Pipe Section Design

d) Flexible Hose,

e) Filter/ Dust Sack,

f) Motor/Fan/Impeller Unit

g) Exhaust

h) Power Control/Switch

i) Housing Unit

j) Unit Mobility.

3.1.1 Determine the Area of Application of the proposed Vacuum Cleaner.

The proposed vacuum cleaner is primarily intended for indoor domestic use. Its design, functionality, and features are optimized for cleaning homes, apartments, and other indoor spaces. The vacuum cleaner is not designed for heavy-duty or commercial use but rather for regular maintenance and cleaning in residential settings.

3.1.2 Determine the Dust Particle Type and Size to be dealt with by the Vacuum Cleaner.

Determining the size and type of dust particles a handheld vacuum cleaner needs to handle is crucial for designing its filtration system and suction power. We start by identifying the range of particle sizes typically found in household dust, which can vary from 0.5 to 100 micrometers in diameter.

To understand the distribution of particle sizes, engineers often use the Cumulative Distribution Function (CDF) or Differential Distribution Function (DDF). These functions help determine the percentage of particles below a specific size or within a size range.

We conducted a physical survey to identify the types of dirt particles commonly found in households. Based on our analysis, we found that the vacuum cleaner should handle particles up to 1 centimeter in size. For estimating the weight of dirt, we simplified the process by assuming the heaviest type of dirt. Our analysis suggests that the vacuum cleaner would encounter a maximum weight of 0.5 grams of dirt during operation.

By understanding the size, type, and weight of dirt particles, we can design a filtration system and suction power that meets the requirements of typical household cleaning tasks.

It is important to carry out actual physical survey of the dirt types that can be found in an average house hold. Some of these dirt particles found in the average house hold room are shown below:

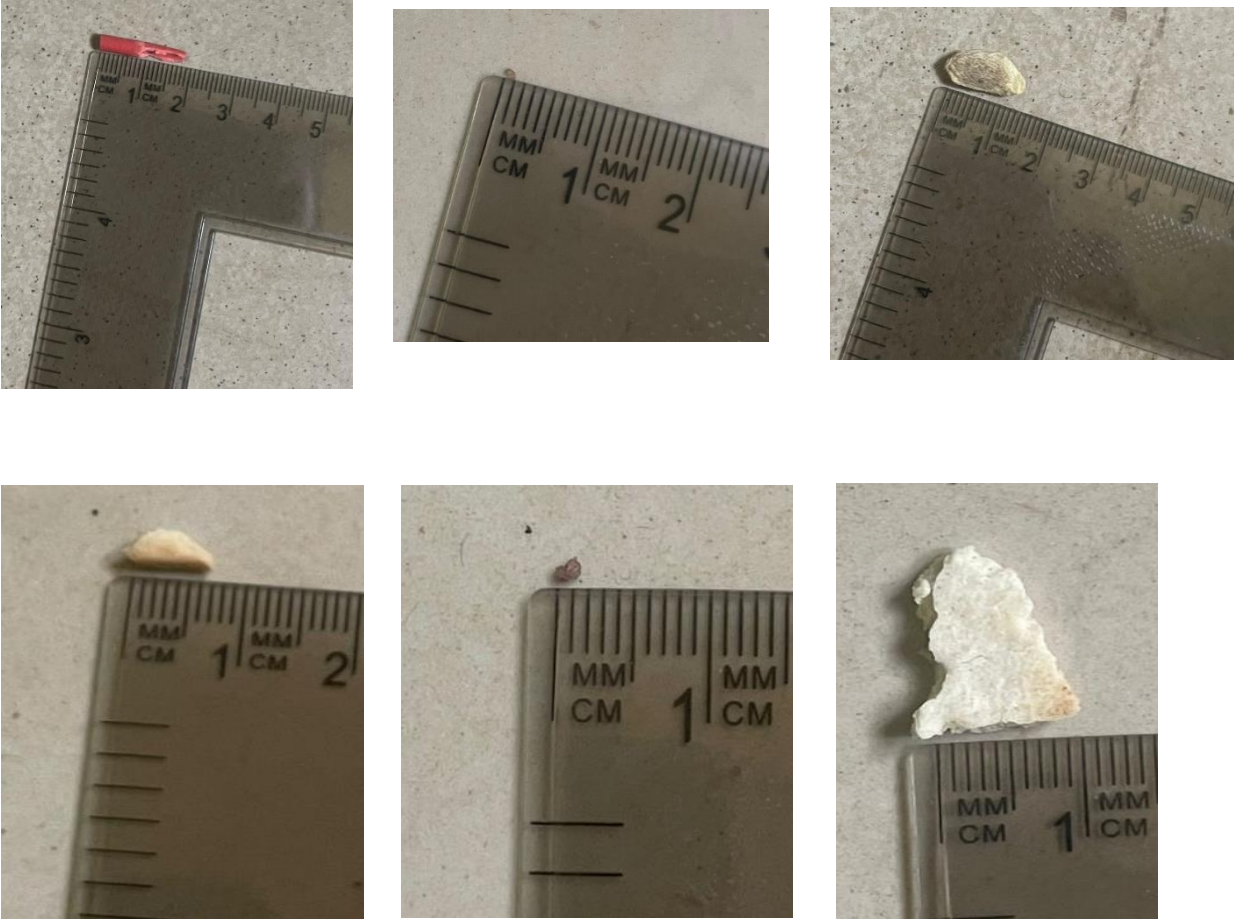

Figure 3.1 – Size analysis of dirt particles found in a household

3.1.3 Determine the Size of the proposed Vacuum Cleaner

The design of a portable backpack vacuum cleaner for indoor domestic application requires careful consideration of its size to ensure optimal performance and user satisfaction. A vacuum cleaner that is too large or heavy may be cumbersome to use, while one that is too small may compromise cleaning efficiency. Therefore, determining the ideal size of the

vacuum cleaner is crucial for achieving the desired balance between functionality and user-friendliness.

The dust bag capacity was set at 1 litres. The intended vacuum cleaner is designed to be portable and lightweight, allowing it to be comfortably carried on the shoulders like a backpack. A weight limit of less than 10 kg was established.

3.1.4 Determine the Source of Power for the proposed Vacuum Cleaner

We decided on an AC Power Drive/Motor for the proposed vacuum cleaner. One could argue for DC power due to its efficiency and suitability for portable devices. However, overall, AC power was chosen for its reliability and robustness. AC motors are known for their ability to handle voltage fluctuations, making them more suitable for use in various environments. Additionally, AC motors can provide higher power outputs compared to DC motors, which is beneficial for achieving the desired suction power in a vacuum cleaner.

3.1.5 Selection of Vacuum Cleaners options from the Literature Review that match the criteria determined from 1 – 3 above

From the literature review, the backpack vacuum cleaner emerged as a suitable option for the proposed vacuum cleaner. Its portability, lightweight design, and efficient cleaning performance align with the criteria established for our vacuum cleaner design.

3.1.6 Design of the Components of the proposed Vacuum Cleaner

3.1.6.1 Conceptual Design

A. Design Concept One

This concept is inspired by the portable vacuum cleaner design. The design is very simple yet functional. The components are all standard parts of the vacuum cleaner.

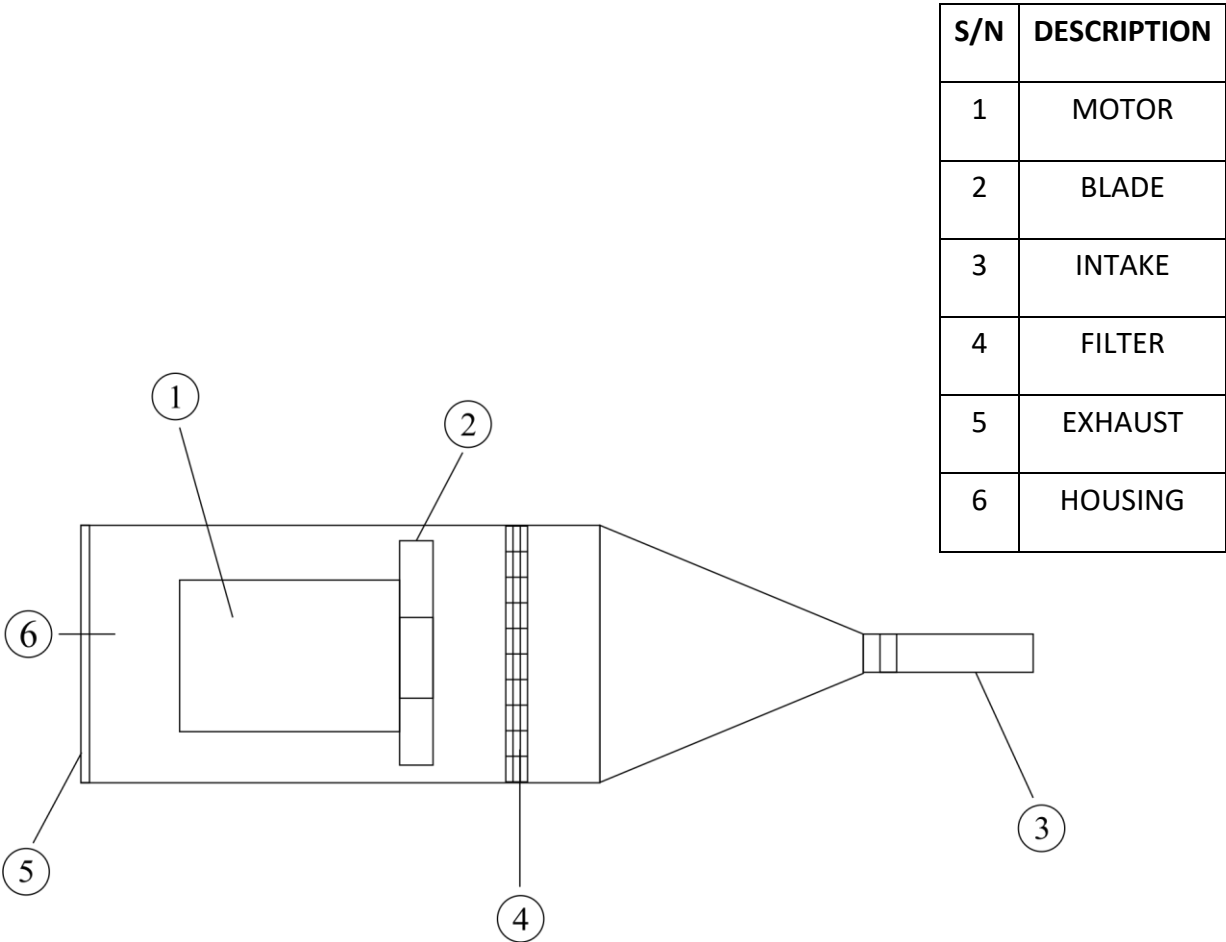
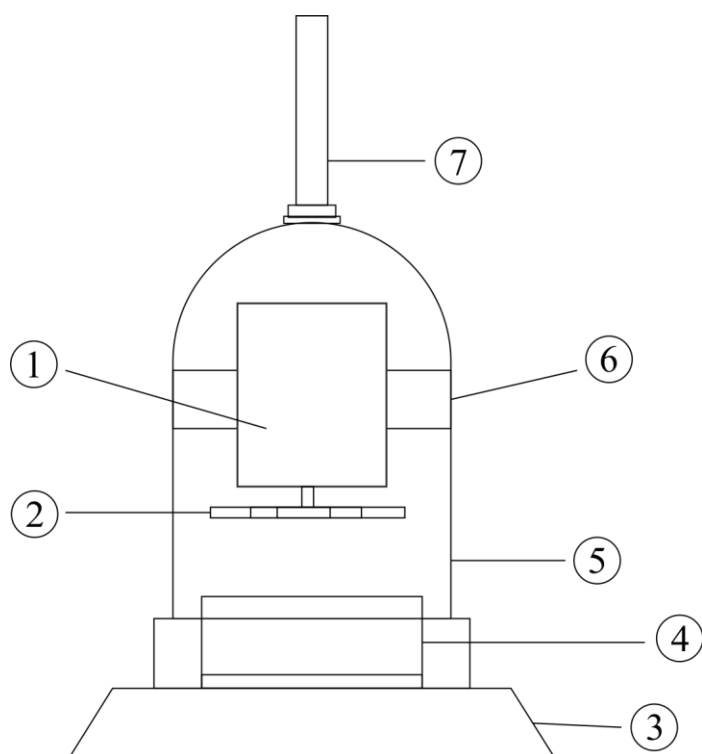

Figure 3.2 – Diagram of design concept one

B. Design Concept Two

This concept is inspired by the upright vacuum cleaner design. It is made up of standard components of the vacuum cleaner; the intake is positioned on the floor, so it is moved like a mop or broom.



S/N	DESCRIPTION
1	MOTOR
2	BLADE
3	INTAKE
4	FILTER
5	HOUSING
6	MOTOR MOUNT
7	HANDLE

Figure 3.3 – Diagram of design concept two

C. Design Concept Three

This concept is inspired by the cylinder vacuum cleaner design. It is made up of standard components of the vacuum cleaner.

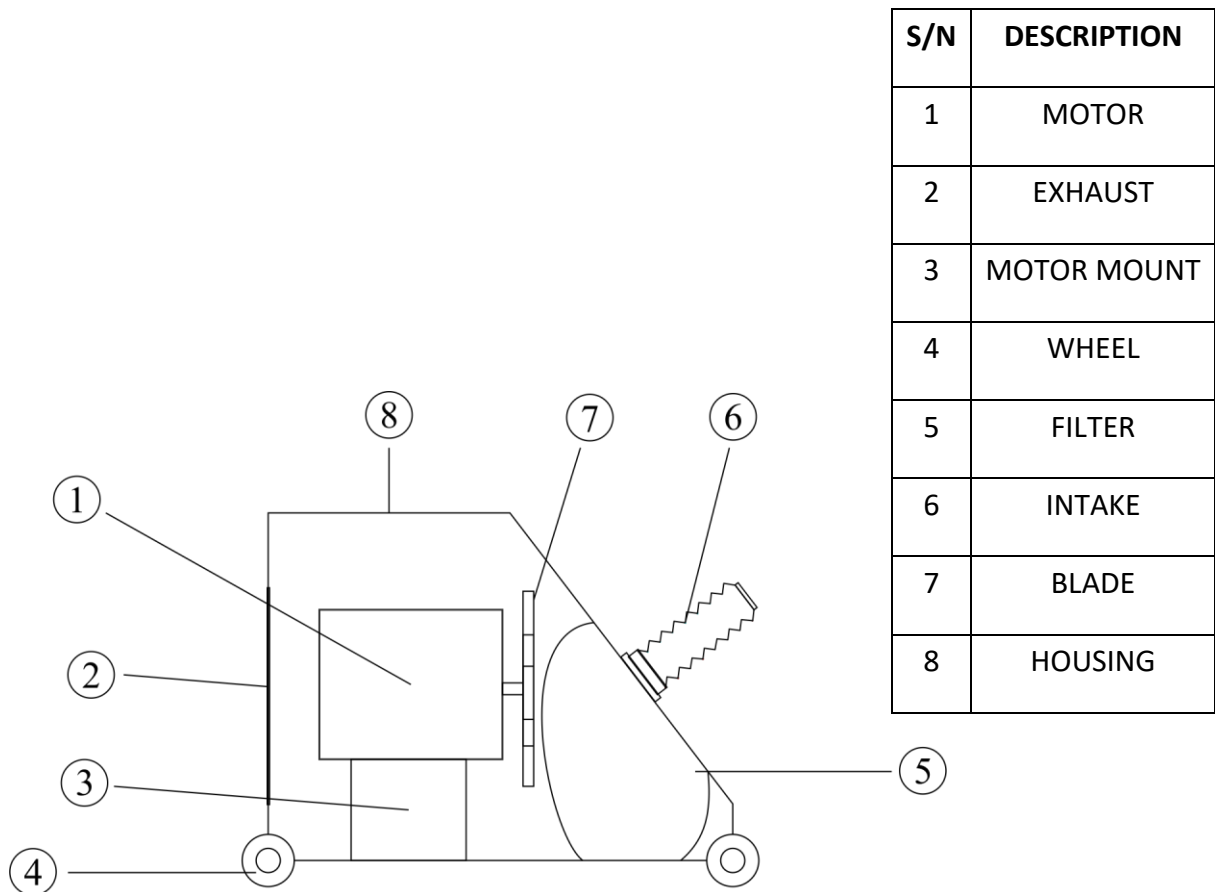

Figure 3.4 – Diagram of design concept three

D. Selection of Conceptual Design

Decision matrix was used to select the best concept for detailed design and fabrication.

Details of the matrixes are shown in the table below.

Criteria	Weight	CONCEPT 1		CONCEPT 2		CONCEPT 3	
		Rating	Score	Rating	Score	Rating	Score
Cost	5	4	20	3	15	3	15
Simplicity	5	4	20	2	10	2	10
TOTAL	10		40		25		25

Table 3.1 – Decision matrix used to rank developed conceptual design

Design concept one with the highest score was considered the best concept for detailed design and fabrication.

3.1.6.2 Design

a) Air Jet Speed Design for Dust Particle Type and Size Pickup

The air jet speed depends on the motor. The motor is the heart of the vacuum cleaner, which will mainly determine the quality of the cleaner (Wang, W., et al., 2012).

To design the air jet speed for a household vacuum cleaner, we'll design the air jet speed based on the weight of the heaviest particle (0.2 grams).

0.5g , that is a force of $5 \times 10^{-3} \text{N}$

Now let's calculate for the vacuum cleaner

To get the lifting force of the vacuum cleaner, we need to get the pressure from the velocity

The only way to simply connect pressure and velocity is by using the law of conservation of energy, which the simple form of the Bernoulli equation is based on.

$$P_1 + \frac{1}{2}\rho V_1^2 + \rho gh_1 = P_2 + \frac{1}{2}\rho V_2^2 + \rho gh_2 \quad (3.1)$$

P_1 and P_2 are the pressures at points 1 and 2 (inlet and outlet),

ρ is the density of air (assumed to be 1.225 kg/m^3 at standard conditions),

v_1 and v_2 are the velocities at points 1 and 2,

g is the acceleration due to gravity (approximately 9.81 m/s^2),

h_1 and h_2 are the heights at points 1 and 2 (assumed to be equal in this case).

In the context of a vacuum cleaner, we can assume that the height difference h is negligible, and the velocity at the inlet (v_1) is zero (since the air is pulled into the vacuum cleaner from rest). So, the equation simplifies to:

$$P_1 + \frac{1}{2}\rho V_1^2 = P_2 + \frac{1}{2}\rho V_2^2 \quad (3.2)$$

And then to

$$P_1 - P_2 = \frac{1}{2}\rho V_2^2 \quad (3.3)$$

$$V = \sqrt{\frac{2\Delta P}{\rho}} \quad (3.4)$$

Where

A = Cross sectional area

V is the air velocity in m/s,

ΔP is the pressure difference across the air jet in N/m^2

ρ is the air density in kg/m^3 .

Air Density: At room temperature (20°C) and sea level pressure (101.325 kN/m^2), the air density is approximately 1.225 kg/m^3 .

Pressure Difference: The pressure difference depends on the design of the vacuum cleaner.

But since we are not designing the motor, we have no control over the speed; we can only choose an appropriate speed for our design. For locally available motors, sometimes the only specification given is the rotational speed in rpm, we need to convert this to m/s

$$\text{Speed (m/s)} = \frac{2 \times \pi \times \text{RPM} \times \text{Radius (m)}}{60} \quad (3.5)$$

Where:

π (pi) is approximately 3.14159

RPM is the motor speed in revolutions per minute

Radius is the radius of the rotating part in meters

So let's calculate

Volume flow rate (Q) experimentally gotten is $0.62 \text{ m}^3/\text{min} = 0.0103 \text{ m}^3/\text{s}$

We have chosen a motor with a rotational speed of 13,000 rpm

$$\text{Speed (m/s)} = \frac{2 \times \pi \times 13,000 \times 0.0615}{60}$$

Speed of blades (m/s) = 83.723 m/s

To get the speed of the air, we use volume flow rate

$$\text{Airflow rate} = \text{Velocity} \times \text{Cross-sectional Area} \quad (3.6)$$

$$Q = V \times A \quad (3.6)$$

$$V = \frac{Q}{A} \quad (3.7)$$

$$V = 81.3 \text{ m/s}$$

$$V = \sqrt{\frac{2\Delta P}{\rho}}$$

$$\Delta P = \frac{1}{2}\rho V_2^2$$

$$\Delta P = 4,048.93 \text{ N/m}^2$$

This is close to the typical pressure range of a standard vacuum cleaner.

To get the lifting force, we use the formula

$$F = P \times A \tag{3.8}$$

Using the outlet diameter of 0.5 inches which is 0.0127 metres

$$A = \pi r^2 \tag{3.9}$$

$$A = 0.0001267\text{m}^2$$

$$F = 4,048.93 \times 0.0001267$$

$$F = 0.513 \text{ N}$$

So we can conclude that this motor is sufficient

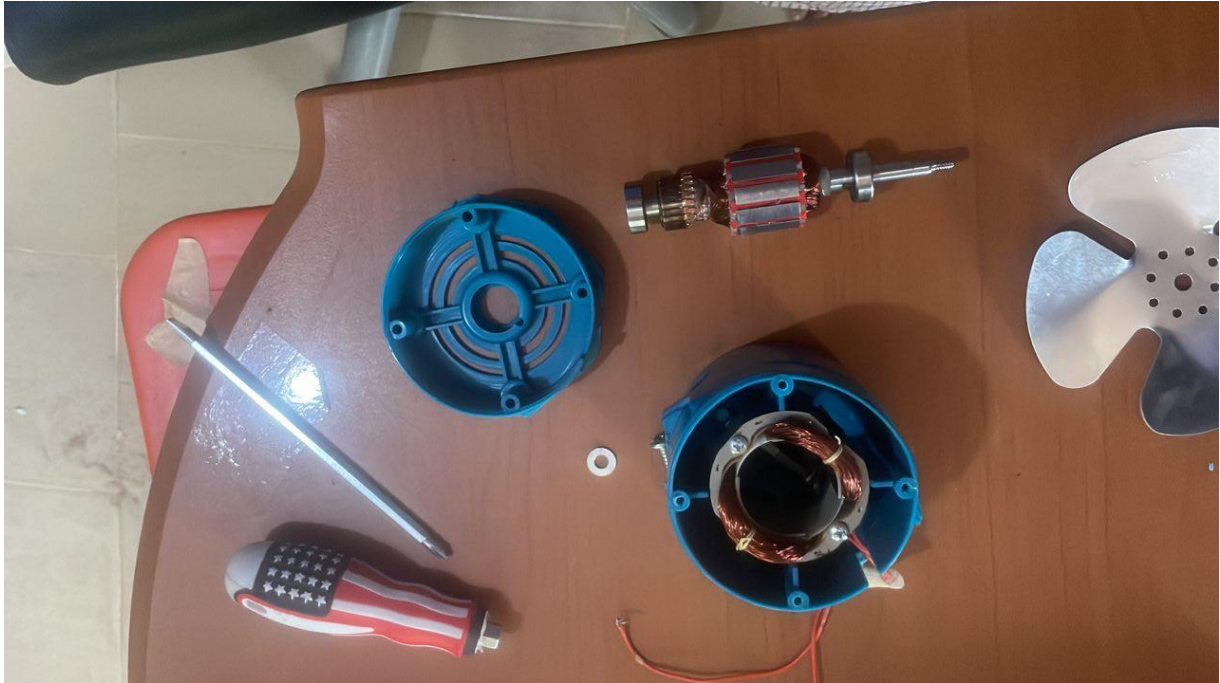

Figure 3.5 – AC Motor from old blower

b) Dust Particle Type and Size Agitation Mechanism Design

We have identified that households commonly contain various types and sizes of dust particles. To effectively remove tightly held dirt, especially in rugs, we have incorporated an agitation mechanism. This mechanism helps loosen and dislodge dirt particles, making them easier to vacuum. The mechanism essentially consists of a modified 1.5-inch pipe section, where a strip has been removed and attached to the wand.



Figure 3.6 – Agitator Mechanism

c) Air Stream Conveyor Rigid Pipe Section Design

For the rigid pipe section of the vacuum cleaner (the wand), PVC pipes were utilized. To reduce the inlet diameter from the 6-inch diameter housing, two reducers were employed: a 6 to 4-inch reducer followed by a 4 to 2-inch reducer. To further enhance mobility, an adjustable pipe was added to the wand. This adjustment was followed by a reduction to the rigid pipe size of 0.5 inches. While this diameter choice may result in a lower pressure differential compared to typical designs, it was selected to increase suction efficiency. The use of a smaller area diameter in the slimmer area allows for higher airflow velocity, thereby improving the vacuum's overall performance.



Figure 3.7 – Rigid 0.5 inch PVC pipe for wand



Figure 3.8 – 6 to 4 Inches reducer



Figure 3.9 – 4 to 2 Inches reducer

d) Flexible Hose

To provide flexibility and reach, we opted for a PVC adjustable pipe with a diameter of 1.5 inches for the flexible hose. This allows users to adjust the length of the hose according to their cleaning needs, enhancing the usability of the vacuum cleaner.



Figure 3.10 – Flexible hose

e) Filter/ Dust Sack

For the filtration system, we chose a fine cloth filter material over foam and paper filters. The fine cloth material offers superior filtration efficiency and durability, ensuring that even the smallest dust particles are captured and retained.



Figure 3.11 – Nylon filter

f) Motor/Fan/Impeller Unit

The motor/fan/impeller unit features an aluminum fan blade with a diameter of 12.3 cm. This choice was made to optimize airflow and suction power. The lightweight and durable nature of aluminum makes it ideal for high-speed applications, contributing to the overall performance and efficiency of the vacuum cleaner.



Figure 3.12 – Locally available Fan blades

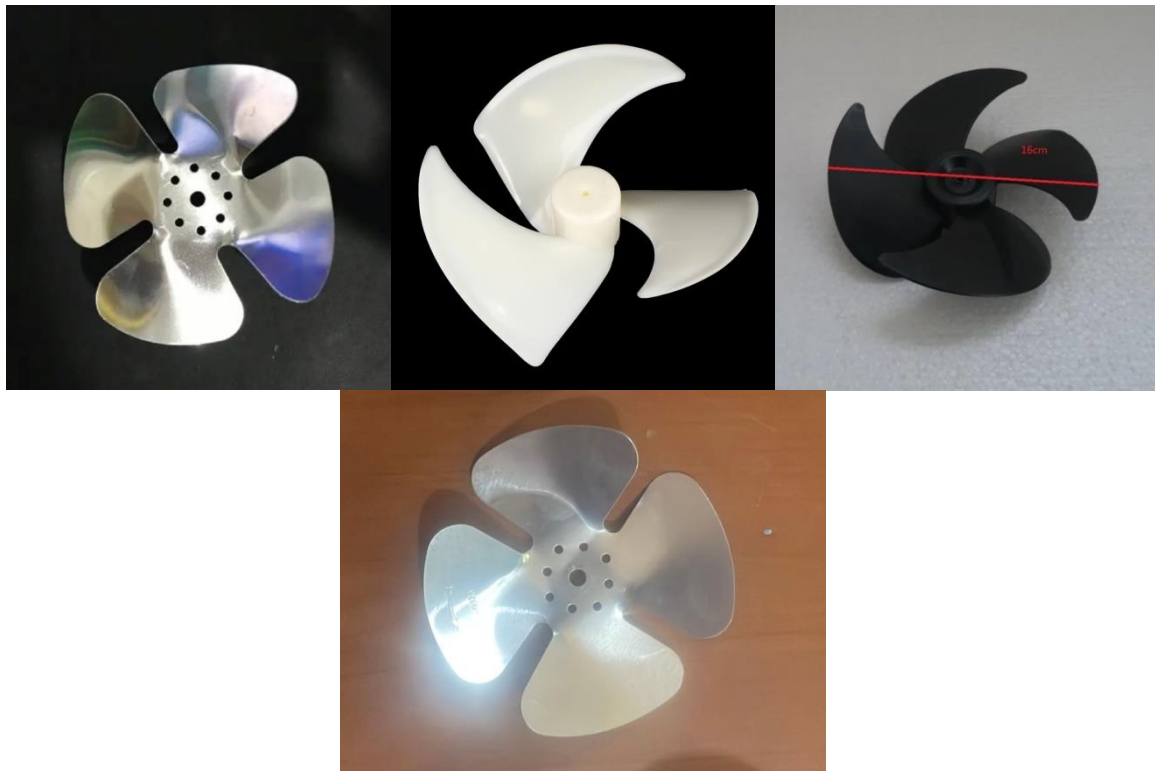

Figure 3.13 – Fan blades considered for the design

g) Exhaust

To maximize space for the exhaust and ensure efficient airflow, we placed the motor at the base of the housing unit. This design allows for unrestricted airflow and minimizes noise levels, enhancing user comfort during operation.



Figure 3.14 – Exhaust Side of the vacuum Cleaner

h) Power Control/Switch

For user convenience, we incorporated an on-button switch into the design. The placement and design of the switch were carefully considered to ensure ease of use and accessibility.

i) Housing Unit

The housing unit is constructed from a 6-inch cylindrical pipe. This choice provides a sturdy and durable housing for the vacuum cleaner components, ensuring long-lasting performance. The cylindrical shape also helps optimize airflow and minimize air resistance.

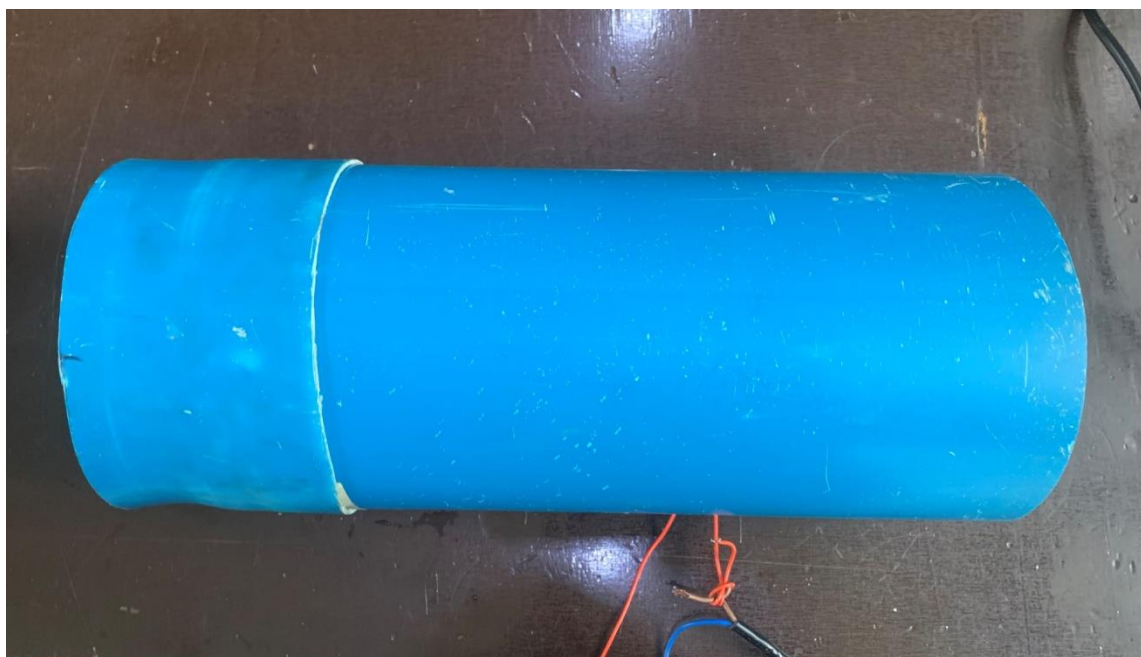

Figure 3.15 – 6 inches Pipe housing

j) Unit Mobility

To improve mobility, we added a strap to the vacuum cleaner. This allows users to easily carry the vacuum cleaner from one location to another, enhancing usability and convenience.



Figure 3.16 – Strap for easier unit mobility

Materials

Component	Material Used	Justification
Body	Plastic PVC Pipe	Lightweight, durable, and readily available material that can be easily shaped and assembled.
Wand	PVC Pipe	Flexible, lightweight, and durable material suitable for directing airflow without kinking or leaking.
Nozzle	PVC Pipe	Easy to shape and customize for specific cleaning needs, while remaining durable and lightweight.
Motor	Repurposed Electric Motor	Cost-effective and readily available

		source of power for generating suction in the vacuum cleaner.
Filter	Cloth	Provides effective filtration of dust particles while allowing airflow, easy to replace or clean.
Power Supply	AC Adapter	Provides a stable power source, suitable for household use.

Table 3.2 – Vacuum cleaner components and locally available material used

3.2 Morphological Chart

Component/Feature	Option 1	Option 2	Option 3
Body Material	Plastic PVC	Sheet Metal	Flexible Composite Material
Suction Power Source	Old blower Motor (13,000rpm)	Old blender motor (10,000rpm)	AC Motor (15,000rpm)
Filter Type	Cloth Filter	Foam Filter	Paper Filter

Table 3.3 – Morphological Chart

3.3 Fabrication Process

1. Prepare the Body: Cut an appropriate length of the 6-inch PVC pipe, say 0.20m to fit the motor assembly.

2. **Motor Assembly:** Attach the electric motor to the end of the PVC pipe using screws or adhesive, ensuring it is securely in place and aligned with the pipe.
3. **Create the Airflow Path:** Connect a shorter piece of PVC pipe to the outlet of the motor to direct the airflow. Seal any gaps with adhesive or tape to prevent air leaks.
4. **Attach the Hose and Nozzle:** Attach a longer piece of PVC pipe to the other end of the airflow path to act as the hose. Attach a narrower piece of PVC pipe to the end of the hose to act as the nozzle.
5. **Install the Filter:** Cut a piece of cloth or foam to size and attach it to the inside of the PVC pipe, covering the motor assembly. This will act as the filter.
6. **Connect the Power Supply:** Wire the motor to a suitable power supply, such as a battery or AC adapter, ensuring proper insulation and safety measures are in place. Consider adding a switch for easy on/off control.

3.3.1 Tools Used for Fabrication

Tool	Purpose
Screwdriver	Attaching components
Drill	Creating holes
Saw	Cutting PVC pipe
Adhesive or Tape	Sealing
Measuring tape	For taking accurate measure

Table 3.4 – Tools used for fabrication

3.3.2 Challenges Encountered During Fabrication and Solutions

Sealing Air Leaks: Use adhesive or tape to seal any gaps in the airflow path to ensure maximum suction power.

Motor Compatibility: Ensure the electric motor used is compatible with the power supply and provides sufficient suction power for the vacuum cleaner.

Safety Concerns: Insulate all electrical connections properly to prevent electric shocks. Use the vacuum cleaner in a well-ventilated area to avoid inhaling dust and debris.

3.4 Optimization of the Vacuum Cleaner

We tried to make it as optimal as possible and also satisfy all the requirements of a good vacuum cleaner.

Three of the most important requirements of a good vacuum cleaning machine are as follows;

1. It should produce an even suction at all times
2. The suction should be great enough to loosen the dirt from the fabric but not great enough to injure the fabric
3. The amount of air handled by the fan should be large enough to remove the loosened dirt and purify the fabric at the same time. (Whitnall, C.A., 1911)

Suction power is a very important parameter. Suction power in a vacuum cleaner is influenced by several key factors:

- **Motor Power:** The strength of suction is directly related to the speed of the motor. The more the speed of the motor, the more the suction. However, there is a trade-off to

consider, as higher motor speeds can also lead to increased noise levels and energy consumption.

- **Air Passageway Blockage:** A clean vacuum bag and filter are essential for maintaining optimal airflow and suction power. If air flow is constricted because of blockages in the filter, the particles of air would move more slowly and thus decrease the suction power.
- **Intake Port Size:** A smaller intake port increases air speed, resulting in greater suction force due to Bernoulli's principle. Narrower attachments create stronger suction as they force air to move faster through them. Since the speed of the vacuum fan is constant, the amount of air passing through the vacuum cleaner per unit of time is also constant. No matter what size you make the intake port, the same number of air particles will have to pass into the vacuum cleaner every second. If you make the port smaller, the individual air particles will have to move much more quickly in order for them all to get through in that amount of time.
- **The design of the fan blades:** This also has a significant impact on suction power. The shape and orientation of the blades can affect the airflow pattern inside the vacuum cleaner, which in turn influences suction power. Almasi et al. (2022) observed that fan blades can be optimized to increase suction.
- **Airflow Path:** The design of the airflow path inside the vacuum cleaner can influence suction power. Smooth, unobstructed airflow paths are more efficient and can result in higher suction power. Design features such as bends, curves, and obstructions can reduce airflow and lower suction power.
- **Seal and Gasket Quality:** The quality of the seal and gaskets in the vacuum cleaner can affect suction power. A tight seal ensures that air is drawn through the vacuum cleaner and not leaked out, maximizing suction power.

In the optimization phase of our project to fabricate a vacuum cleaner from locally available materials, several key challenges were encountered and addressed to enhance the performance and efficiency of the device.

The speed of the motor is constant and cannot be increased and so we concentrated on other aspects. We focused on optimizing the blade and enhancing the filter system. We experimented with different blade shapes and types that we found to maximize airflow and suction power. Additionally, we explored various filter materials and configurations to improve dust and debris capture efficiency without compromising airflow.



Figure 3.17 – Broken Plastic Fan blade from stress failure

Another critical aspect of optimization was ensuring airtightness to prevent air leaks and maximize suction power. We carefully sealed all seams and joints in the vacuum cleaner body to eliminate any potential leakage points. This meticulous sealing process significantly enhanced the overall performance of the device.

Furthermore, we optimized the intake port size to balance airflow and suction power. By reducing the intake port size to 0.5 inches, we were able to increase the air velocity entering the vacuum cleaner, thereby enhancing suction power while maintaining optimal airflow.

Overall, through systematic optimization efforts focused on blade design, filter system, airtightness, and intake port size, we were able to significantly improve the performance and efficiency of our locally fabricated vacuum cleaner.

3.5 Vacuum Cleaner Views

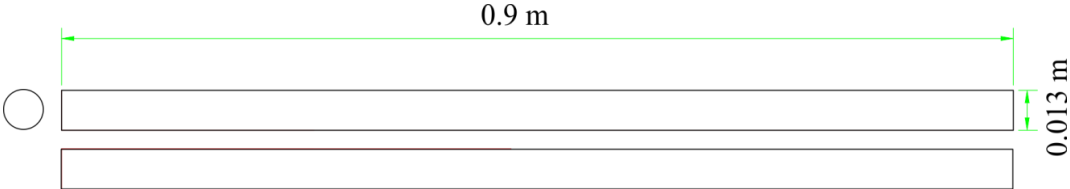

Figure 3.18 – Orthographic view of the Wand

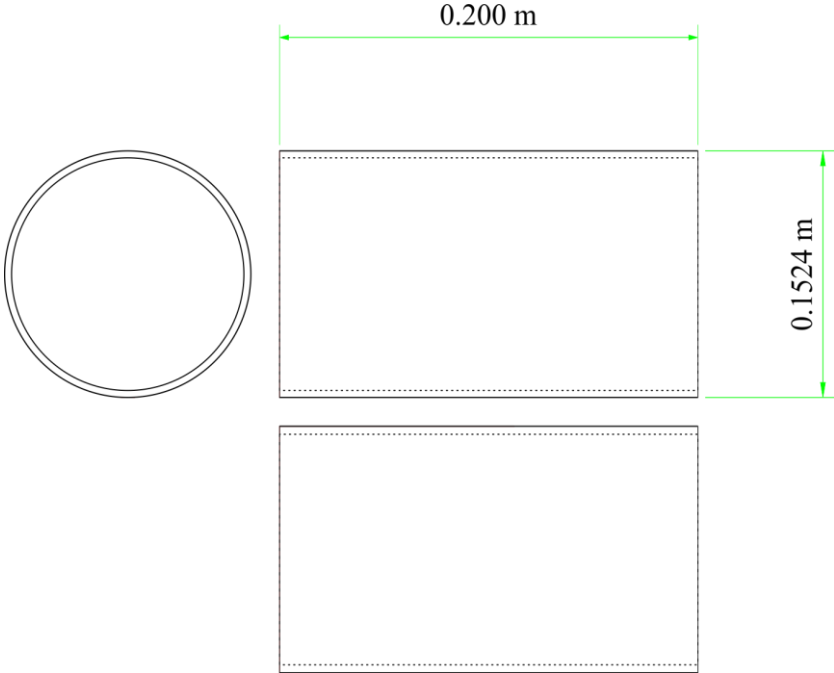

Figure 3.19 – Orthographic view of Pipe Housing

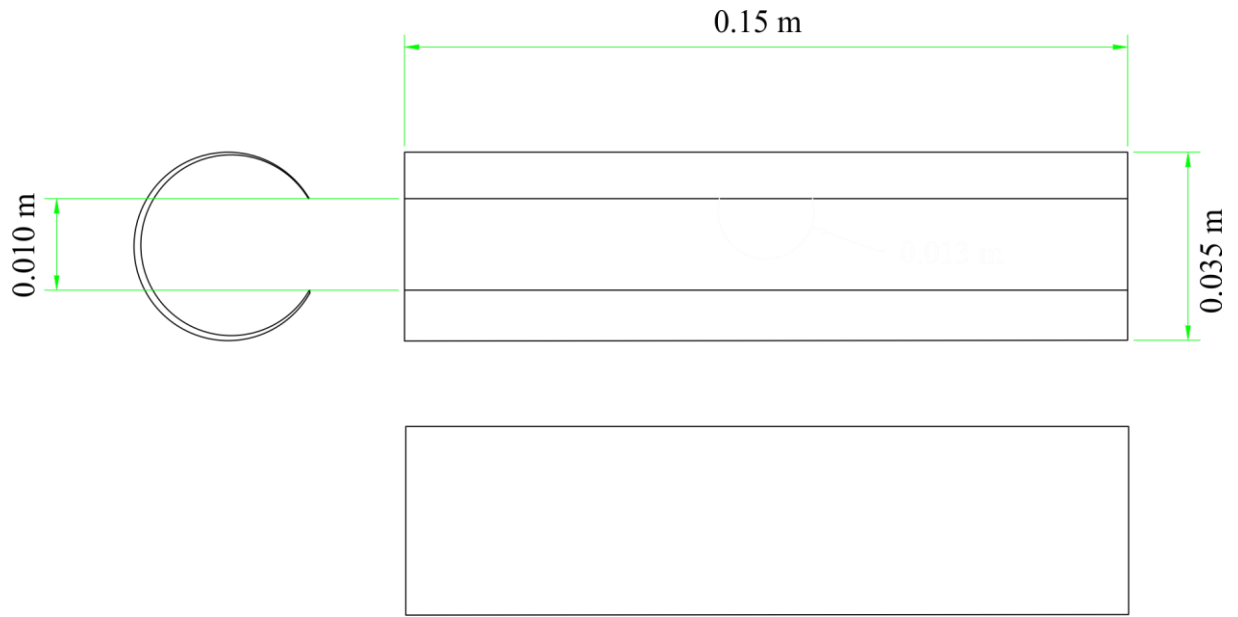

Figure 3.20 – Orthographic view of Agitator Mechanism

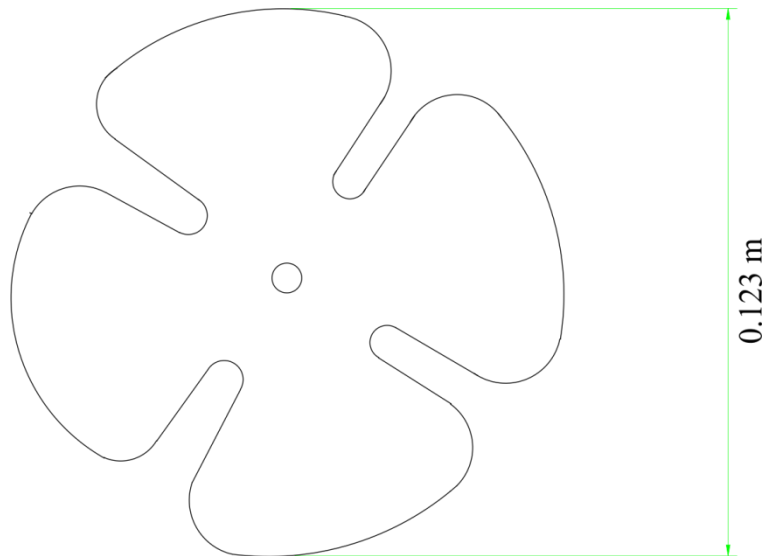

Figure 3.21 – Plan View of Blade

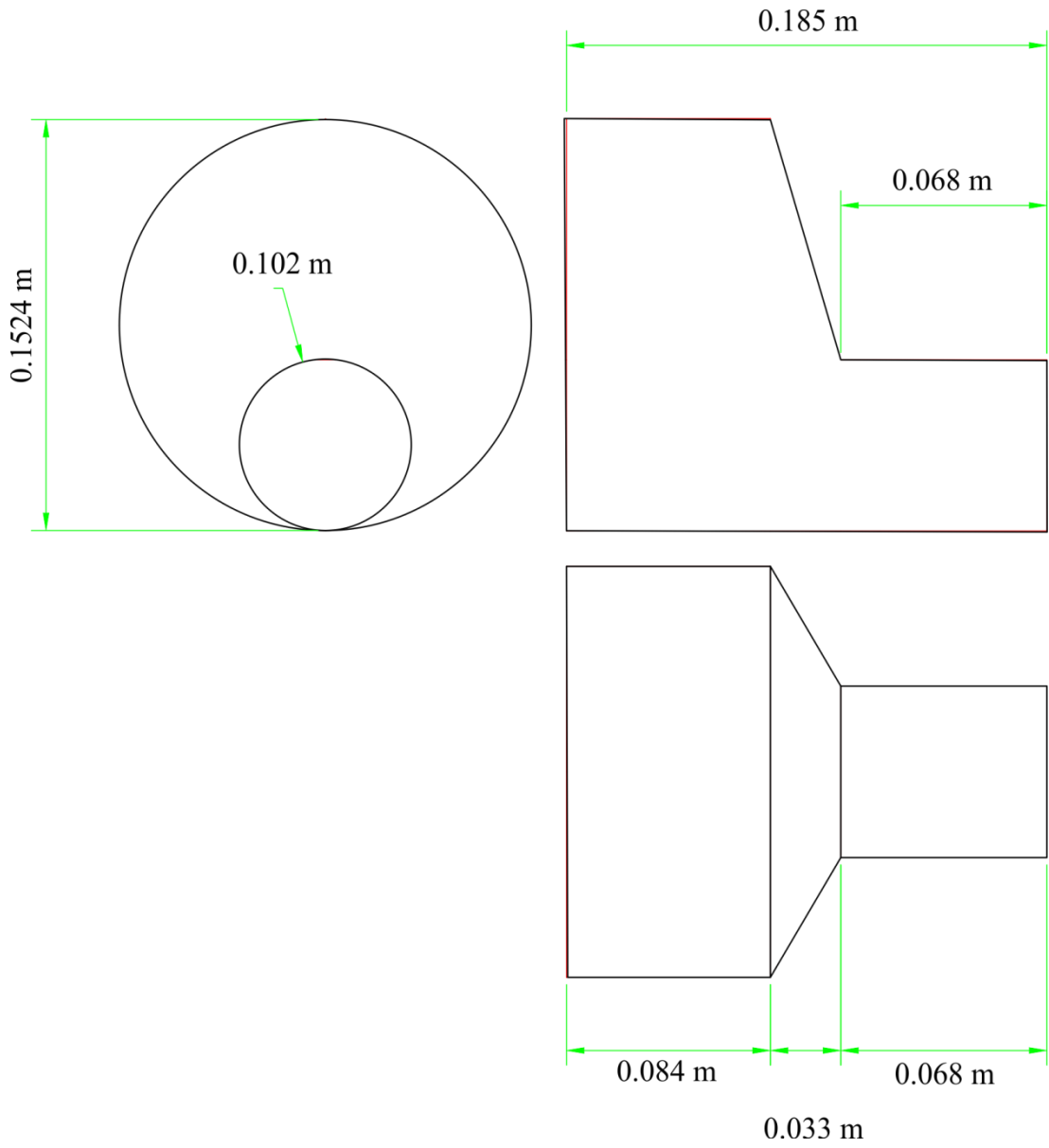

Figure 3.22 – Orthographic view of 6 to 4 Inches Pipe reduction Joint

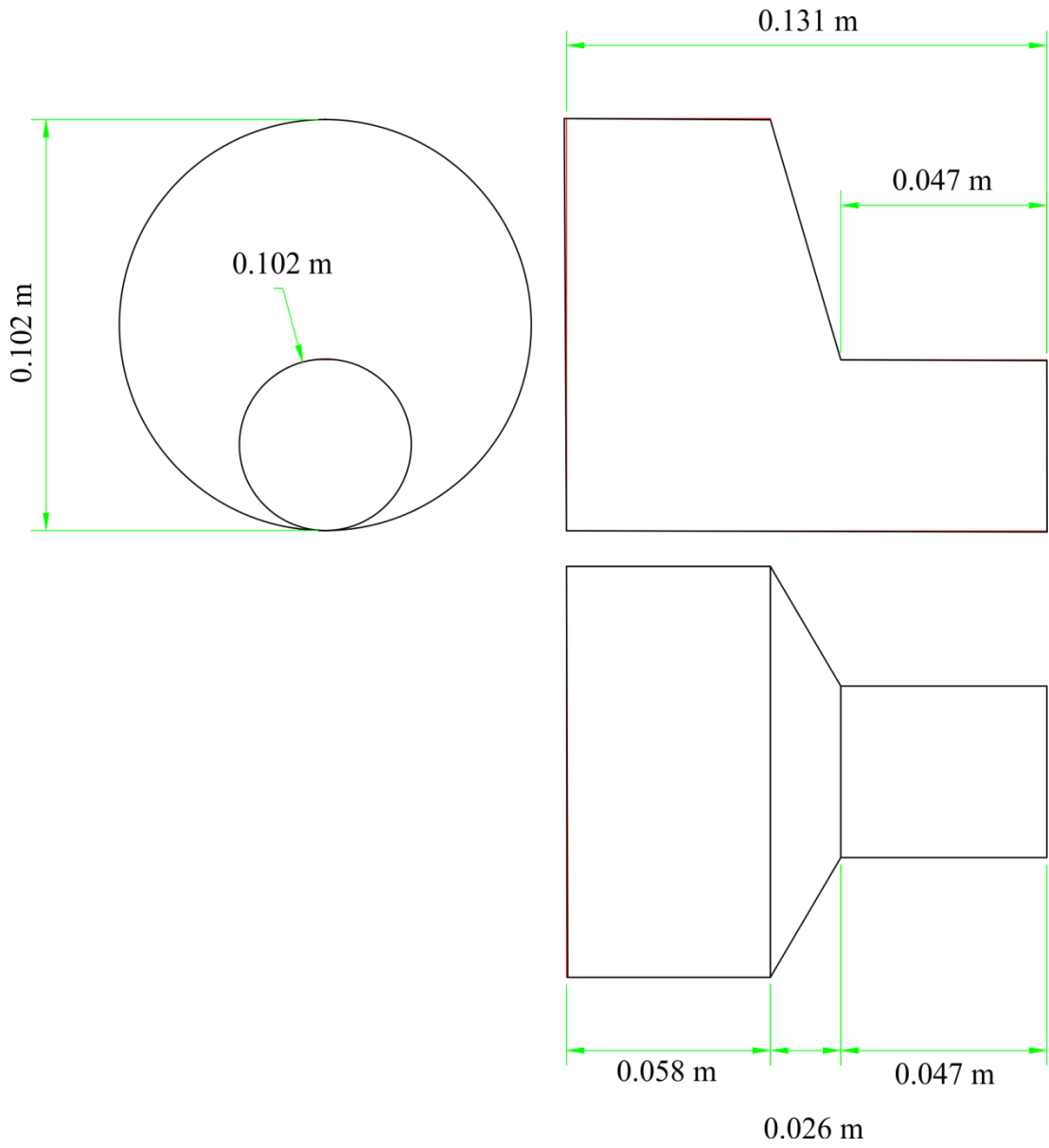

Figure 3.23 – Orthographic view of 4 to 2 Inches Pipe reduction Joint

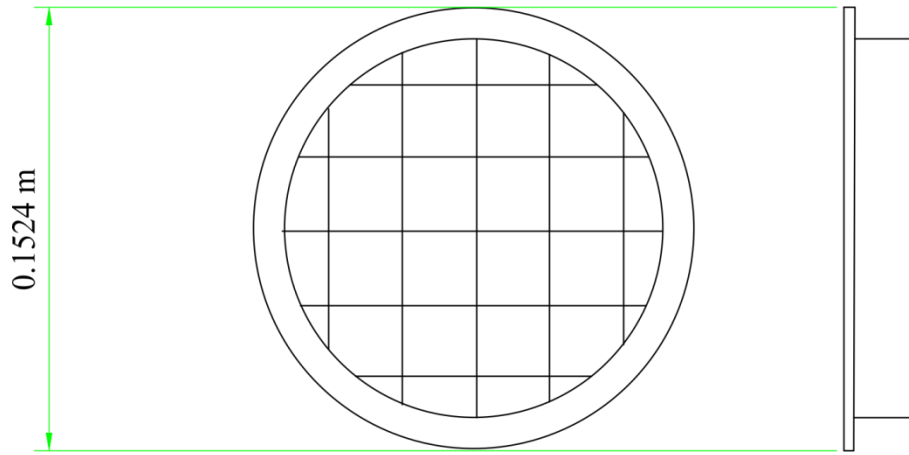

Figure 3.24 – Orthographic view of Exhaust Cover

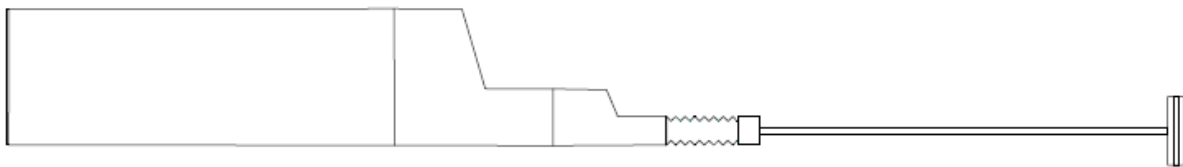

Figure 3.25 – View of the Vacuum Cleaner assembly

3.6 Specification

To specify the rated power and suction power of this vacuum cleaner, we depend on the motor. For an AC motor, the rated power is typically provided by the manufacturer in the motor's specifications. This information can be found on the motor's nameplate or datasheet. If the motor's specifications are not available, you will need to measure its parameters using devices like a power meter.

In our case, we already have the motor's specification, which states that the rated power is 700 watts.

To get suction power, we need to know the airflow rate and the vacuum pressure.

$$\text{Suction Power} = \text{Vacuum Pressure} \times \text{Airflow rate} \quad (3.10)$$

$$S = \Delta P \times Q \quad (3.10)$$

$$S = 4,048.93 \times 0.0103$$

$$S = 41.70$$

Although the unit is different, the suction power is usually just still expressed in pressure

$$S = 41.7 \text{ Pa}$$



Figure 3.26 – Picture of the Vacuum Cleaner in Design Stage

S/N	DESCRIPTION
1	MOTOR
2	FILTER FRAME
3	FILTER CLOTH
4	JOINT
5	1.5" FLEXIBLE PIPE
6	0.5" RIGID PIPE
7	AGITATION MECHANISM
8	REDUCING JOINT
9	4 TO 2" REDUCER JOINT
10	6 TO 4" REDUCER JOINT
11	6" PIPE HOUSING
12	MOTOR MOUNT
13	BLADE
14	EXHAUST

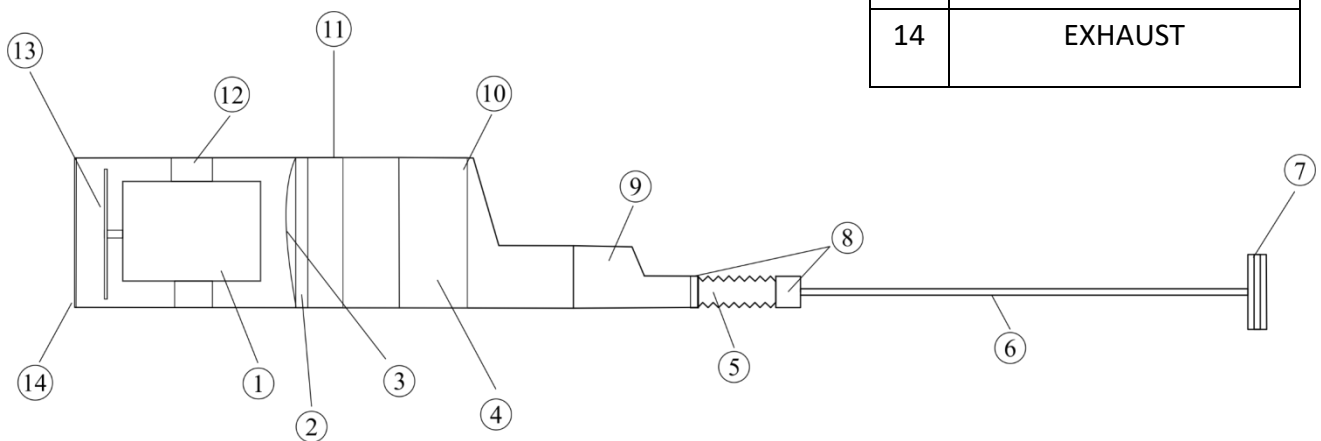

Figure 3.27 – Diagram of the Vacuum cleaner design

CHAPTER FOUR

RESULT

The vacuum cleaner was meticulously tested and analyzed the vacuum cleaner to evaluate its effectiveness, usability, and ergonomics. This involved comparing its performance to that of commercial vacuum cleaners currently available in the market.

Can this vacuum cleaner provide an enjoyable experience? MINTEL (2010) ranked factors that consumers report influencing their purchase of a vacuum cleaner.

1. Suction power
2. Easy to move around
3. Lightweight
4. Easy to store
5. Suitable for hard and soft surfaces. (Harmer, L., et al., 2015)

4.1 Testing and Performance Evaluation

4.1.1 Performance Evaluation Criteria

The following performance criteria was developed

1. Suction Power: The vacuum cleaner should have sufficient suction power to pick up dust and debris effectively.
2. Mobility: The vacuum cleaner should be easy to move around
3. Weight: The vacuum cleaner should be lightweight

4. Dust Collection and filtering: The vacuum cleaner should be able to collect dust and debris and filter it without releasing it back into the atmosphere.
5. Noise Level: The vacuum cleaner should produce minimal noise during operation to ensure user comfort.
6. Durability: The vacuum cleaner should be able to withstand regular use without experiencing significant wear or damage.

4.1.2 Testing Methods

- Suction Power Test: The suction power of the vacuum cleaner was tested in a number of environments to envisage the performance, such as lifting a standard weight with the nozzle at a specified distance.
- Weight test: The weight of the vacuum cleaner was measured.
- Noise Level Test: The noise level produced by the vacuum cleaner during operation was also measured using a sound level meter.
- Durability and Usage Test: The vacuum cleaner was run continuously for a specified period of 1 hour to test its durability and filtering efficiency under normal operating conditions.

4.1.3 Results and Discussion

Suction Power: The homemade vacuum cleaner was able to lift a standard weight of 0.2 grams at a distance of 0.5 centimeters, indicating sufficient suction power.

Weight test: The weight of the vacuum cleaner was 3.3 kg.

Noise Level: The vacuum cleaner produced a noise level of 110 decibels during operation, which is within acceptable limits for household use.

Criteria	Description
Suction Power	Sufficient to pick up dust and debris effectively
Weight	Light weight
Noise Level	Within acceptable limits for household use
Durability	Withstands regular use without significant wear or damage
Filtration efficiency	Fairly traps dust particles without releasing them back

Table 4.1 - Performance Evaluation Criteria

4.2 Bill of Engineering Measurement and Evaluation (BEME)

S/N	Component	Material	Dimension	Quantity	Price (Naira)	Total Price (Naira)
1	Electric Motor	N/A	700 watts	1	8,000	8,000
2	Fan blade (rotor)	Aluminum	12.3 cm diameter	1	1,000	1,000
3	Motor mount	Wood	N/A	N/A	-	-

4	Cylindrical housing pipe	PVC	6 inch diameter	1	1,500	1,500
5	Diameter reduction joint	PVC	6 to 4 inch diameter	1	1,500	1,000
6	Diameter reduction joint	PVC	4 to 2 inch diameter	1	1,000	1,000
7	Flexible pipe	PVC	1.5 inch diameter	1	1,200	1,200
8	Reduction joint	PVC	1.5 inch to 0.5 inch	1	200	200
9	Pipe Wand	PVC	0.5 inch diameter	1	1,800	1,800
10	Pipe	PVC	1.5 inch	1	500	500
11	Filter material	Nylon	N/A	-	300	300
15	AC Adapter	N/A	N/A	1	500	500
16	Wiring	N/A	2 meters	-	600	600
17	Screws		2 inch length	4	-	150
18	Adhesive/Tape	N/A	N/A	-	1000	1000

19	Metal Railing			-	200	200
	Total					18,950

Table 4.2 – Bill of Materials

The total material cost for producing this vacuum cleaner is 18,950 Naira, approximately 20,000 Naira. A market survey of home vacuum cleaners indicates that they are priced at over 40,000 Naira and above. While commercial models may offer additional features and attachments, this locally fabricated vacuum cleaner provides a cost-effective solution for household cleaning.

4.3 Comparative Analysis of this Locally Available Materials VS Standard Vacuum Cleaners

1. Materials

Component	Local Vacuum Cleaner	Standard Vacuum Cleaners
Body	Shaped PVC pipes	Customized Plastic or metal bodies
Hose	PVC pipes and wands	Flexible plastic and metal wands
Motor	Repurposed electric motors	Specialized vacuum cleaner motors
Filter	Cloth filter	HEPA filters

Table 4.3- Materials Comparative Analysis

2. Performance

Performance Metric	Local Vacuum Cleaner	Standard Vacuum Cleaners
Suction Power	Moderate	High
Dust Collection	Basic	High efficiency
Noise Level	Moderate	Low
Durability	Basic	High
Usability	Simple design, easy to use	Advanced features, user-friendly
Size and Weight	Light and Compact	Light and compact but could also be Larger and Heavier

Table 4.4- Performance Comparative Analysis

3. Cost

Cost	Local Vacuum Cleaner	Standard Vacuum Cleaners
Purchase Cost	Low	High

Table 4.5- Cost Comparative Analysis

4.4 SWOT Analysis of the Vacuum Cleaner Fabricated from Locally Available Materials

4.4.1 Strengths

- **Cost-Effective:** The vacuum cleaner is much cheaper than purchasing a standard vacuum cleaner.
- **Sustainable:** Utilizing locally available materials reduces the environmental impact associated with manufacturing and transportation.
- **Customization:** The use of locally available materials allows for customization of the vacuum cleaner design to suit specific needs and preferences.
- **Skill Development:** Fabrication of a vacuum cleaner provides an opportunity for individuals to develop skills in engineering, design, and fabrication.
- **Performance:** The performance is good enough to get the work done.

4.4.2 Weaknesses

- **Performance:** The performance is lower compared to some standard vacuum cleaners.
- **Aesthetics:** The design and aesthetics needs to be improved.
- **Features and Accessories:** The features and accessories are limited.

4.4.3 Opportunities

- **Local Production:** Fabrication of vacuum cleaners from locally available materials can stimulate local production and entrepreneurship.
- **Innovation:** Continued innovation in design and materials may lead to improvements in the performance and durability of locally fabricated vacuum cleaners.

4.4.4 Threats

- **Competition:** Standard vacuum cleaner manufacturers may offer competitive products with higher performance and features.
- **Technological Advancements:** Rapid advancements in technology may make standard vacuum cleaners more affordable and efficient, reducing the appeal of locally fabricated alternatives.

The fabrication of a vacuum cleaner from locally available materials offers several advantages, including cost-effectiveness and sustainability. However, challenges such as lower performance compared to standard vacuum cleaners need to be addressed. Continued innovation and market demand for affordable and sustainable solutions present opportunities for growth in this sector.

4.5 Design Analysis and Recommendations

Following extensive testing and analysis throughout the design stages, we have developed several recommendations based on our experience:

1. Opt for a high-speed motor with a high RPM (revolutions per minute) for improved performance.
2. Ensure the vacuum cleaner is airtight to maintain optimal airflow.
3. Use a concentric shape reducer for better airflow efficiency over an eccentric shape.
4. Consider using encased centrifugal fans for the best suction performance.
5. Select a fan with a substantial thickness or opt for a metal fan, such as aluminum, for enhanced durability and performance.
6. Include ergonomic features in the design, such as comfortable handles and lightweight construction, to enhance usability and user comfort.

These recommendations aim to enhance the overall design and performance of the vacuum cleaner, ensuring optimal functionality and efficiency.

Results of detailed design

S/N	Parameters	Unit	Calculated Data
1	Rated Power	Watt (W)	700
2	Suction Power	Pascal (Pa)	41.7
3	Weight	Kilogram (kg)	3.3
4	Noise	Decibels (db)	110
5	Dust bag volume	Liters (l)	0.4

Table 4.6- Results of detailed design

CHAPTER FIVE

CONCLUSION AND RECOMMENDATIONS

5.1 Summary of Key Findings

The fabrication of a vacuum cleaner using locally available materials in Nigeria is feasible and cost-effective.

By following simple design principles and using basic tools, a functional vacuum cleaner can be fabricated for household use.

Locally available materials such as plastic buckets, PVC pipes, and electric motors can be repurposed for vacuum cleaner fabrication.

5.2 Recommendations for Future Studies or Improvements

Further research could focus on optimizing the design of the homemade vacuum cleaner for improved performance and efficiency.

Exploring alternative materials and components that are more readily available in Nigeria could enhance the sustainability of the fabrication process.

Conducting user studies to evaluate the usability and effectiveness of the homemade vacuum cleaner in real-world settings could provide valuable insights for future iterations.

5.3 Conclusion

In conclusion, the fabrication of a vacuum cleaner from locally available materials in Nigeria offers a practical solution for individuals and small businesses looking to access cleaning

equipment at a lower cost. By leveraging simple design principles and readily available materials, it is possible to create a functional vacuum cleaner that meets basic cleaning needs. This study demonstrates the potential for sustainable and cost-effective solutions to be developed using locally available resources.

This project represents an endeavor to enhance the efficiency of cleaning solutions in Nigeria. While traditional craftsmen currently produce brooms, mops, and other cleaning materials manually, this project aims to streamline the process of manufacturing vacuum cleaners. The principles and techniques involved are universal and straightforward, making them accessible for local production. Despite the challenges posed by unstable electricity supply in the country, which is crucial for operating electrical appliances like vacuum cleaners, this should not deter our efforts in local production and development. It is imperative to remain innovative and continuously strive for excellence in our endeavors.

CHAPTER SIX

REFERENCES.

1. AEA, 2009. Work on Preparatory Studies for Eco-Design Requirements of EuPs (II) (TREN/D3/390-2006). Lot 17 Vacuum Cleaners AEA Energy & Environment final report to European Commission, Oxfordshire (United Kingdom) 118 pp.
2. Almasi, S., Ghorani, M.M., Haghghi, M.H.S., Mirghavami, S.M. and Riasi, A., 2022. Optimization of a vacuum cleaner fan suction and shaft power using Kriging surrogate model and MIGA. *Proceedings of the Institution of Mechanical Engineers, Part A: Journal of Power and Energy*, 236(3), pp.519-537.
3. Anıl, E.R.E.N. and Doğan, H., 2022. Design and implementation of a cost effective vacuum cleaner robot. *Turkish Journal of Engineering*, 6(2), pp.166-177.
4. Asafa, T.B., Afonja, T.M., Olaniyan, E.A. and Alade, H.O., 2018. Development of a vacuum cleaner robot. *Alexandria engineering journal*, 57(4), pp.2911-2920.
5. Eidmohammadi, N., 2014. Wet and dry robotic vacuum cleaner.
6. Ejiko, S.O., Erinle, T.J., Onibon, G.L., Ayeni, O.M. and Aliu, O.L., Design and Construction of an Autonomous Motorized (Robotic) Vacuum Cleaner for Student's Standard Room.
7. Gantz, C., 2012. *The vacuum cleaner: a history*. McFarland.
8. Harmer, L., Cooper, T., Fisher, T., Salvia, G. and Barr, C., 2015. The joy of vacuuming? How the user experience affects vacuum cleaner longevity.
9. Hossain, M.S., Sahiduzzaman, G.M. and Nasim, A.S.M., 2023. Design and Fabrication of a Vacuum Cleaner (Doctoral dissertation, Sonargoan University (SU)).
10. Joo, J.M., Lee, J.H., Hong, S.G., Oh, J.K. and Song, H.G., 2007. Low noise vacuum cleaner design. In *Proceedings of the Korean Society for Noise and Vibration Engineering Conference* (pp. 939-942). The Korean Society for Noise and Vibration Engineering.

11. Manasa, M., Vidyashree, T.S., Bindushree, V., Rao, S. and Gowra, P.S., 2021. Smart vacuum cleaner. *Global Transitions Proceedings*, 2(2), pp.553-558.
12. MINTEL 2010. Vacuum Cleaners – UK.
13. Ndunagu, J.N. and Iwuoha, C.W., 2017. Mathematical Modeling of a Robotic Based Vacuum Cleaning System. *International Journal for Computing and ICT Research*, 11(2).
14. Rapa, C.I., Dephtios, E., Mariangga, C. and Patiung, N., 2022, December. A Design And Build A Robot Vacuum Cleaner. In *Journal of Physics: Conference Series* (Vol. 2394, No. 1, p. 012024). IOP Publishing.
15. Rodríguez, J.B. and Benavides, E.M., 2013. The vacuum cleaner as a case study for teaching conceptual design. *ICAD 2013*.
16. V. Kapila, Introduction to Robotics, 2012. engineering.nyu.edu/mechatronics/smart/pdf/Intro2Robotics.pdf.
17. Velumani, S., Bhuvanesh Kumar, V., Midun, K. and Mohanprasath, G., 2022. Design and Development of a Low Cost Handheld Vacuum Cleaner. *International Journal of Trend in Scientific Research and Development*, 6(7), pp.639-644.
18. Wang, W., Li, G.F., Chen, J. and Ma, J.D., 2012. Design of a new device for household cleaning. *Applied Mechanics and Materials*, 201, pp.711-714.
19. Whitnall, C.A., 1911. Design of a vacuum cleaning machine.
20. Yu., X.W., 2001. Principle and application of household appliances. Higher Education Press. China.